 BY JOHNSON CONTROLS	AIR-COOLED SCREW LIQUID CHILLERS
Installation , Operation & Maintenance Manual	FORM NO.: 201.28-NM1.1.EN.GB(1114)

YVAA AIR-COOLED SCREW LIQUID CHILLERS WITH VARIABLE SPEED DRIVE STYLE A

**150 - 500 Tons
527 - 1758KW
2 Compressor
50 Hz
HFC - 134a**



LD15045

HFC-134a

IMPORTANT!

READ BEFORE PROCEEDING!

GENERAL SAFETY GUIDELINES

This equipment is a relatively complicated apparatus. During installation, operation, maintenance or service, individuals may be exposed to certain components or conditions including, but not limited to refrigerants, oils, materials under pressure, rotating components, and both high and low voltage. Each of these items has the potential, if misused or handled improperly, to cause bodily injury or death. It is the obligation and responsibility of operating/service personnel to identify and recognize these inherent hazards, protect themselves, and proceed safely in completing their tasks. Failure to comply with any of these requirements could result in serious damage to the equipment and the property in which it is situated, as well as severe personal injury or death to themselves and people at the site.

This document is intended for use by owner-authorized operating/service personnel. It is expected that this individual possesses independent training that will enable them to perform their assigned tasks properly and safely. It is essential that, prior to performing any task on this equipment, this individual shall have read and understood this document and any referenced materials. This individual shall also be familiar with and comply with all applicable governmental standards and regulations pertaining to the task in question.

SAFETY SYMBOLS

The following symbols are used in this document to alert the reader to areas of potential hazard:



DANGER indicates an imminently hazardous situation which, if not avoided, will result in death or serious injury.

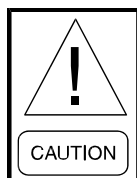

CAUTION identifies a hazard which could lead to damage to the machine, damage to other equipment and/or environmental pollution. Usually an instruction will be given, together with a brief explanation.



WARNING indicates a potentially hazardous situation which, if not avoided, could result in death or serious injury.

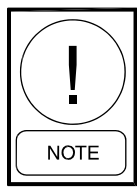

NOTE is used to highlight additional information which may be helpful to you.



External wiring, unless specified as an optional connection in the manufacturer's product line, is NOT to be connected inside the Micro Panel cabinet. Devices such as relays, switches, transducers and controls may NOT be installed inside the panel. NO external wiring is allowed to be run through the Micro Panel. All wiring must be in accordance with Johnson Controls published specifications and must be performed ONLY by qualified Johnson Controls personnel. Johnson Controls will NOT be responsible for damages/problems resulting from improper connections to the controls or application of improper control signals. Failure to follow this will void the manufacturer's warranty and cause serious damage to property or injury to persons.

CHANGEABILITY OF THIS DOCUMENT

In complying with Johnson Controls policy for continuous product improvement, the information contained in this document is subject to change without notice. While Johnson Controls makes no commitment to update or provide current information automatically to the manual owner, that information, if applicable, can be obtained by contacting the nearest Johnson Controls Engineered Systems Service office.

It is the responsibility of operating/service personnel to verify the applicability of these documents to the equipment in question. If there is any question in the mind of operating/service personnel as to the applicability of these documents, then prior to working on the equipment, they should verify with the owner whether the equipment has been modified and if current literature is available.



The Control/VSD Cabinet contains lethal high AC and DC voltages. Before performing service inside the cabinet, remove the AC supply feeding the chiller and verify using a non-contact voltage sensor.



NEVER allow the Control Panel VSD Cabinet doors to remain open if there is a potential for rain to enter the panel. Keep doors closed and assure all latches are engaged on each door unless the unit is being serviced.



The DC voltage on the VSD DC Bus will take 5 minutes to bleed off, after AC power is removed. Always check the DC Bus Voltage with a Voltmeter to assure the capacitor charge has bled off before working on the system.



ALWAYS lockout the disconnect supplying AC to the chiller.



NEVER short out the DC Bus to discharge the filter capacitors.



The 1L Line Inductor will reach operating temperatures of over 150 °C (300 °F.) DO NOT open panel doors during operation. Assure the inductor is cool whenever working near the inductor with power OFF.



NEVER place loose tools, debris, or any objects inside the Control Panel/VSD Cabinet.

ASSOCIATED LITERATURE

Manual Description	Form Number
YVAA Renewal Parts List	Form_201.28-RP1. EN.GB(1201)

TABLE OF CONTENTS

SECTION 1 - GENERAL CHILLER INFORMATION AND SAFETY	5
INTRODUCTION	5
WARRANTY	5
QUALITY ASSURANCE AND SAFETY	5
FLUORINATED GREENHOUSE GASES	5
ABOUT THIS MANUAL	6
MISUSE OF EQUIPMENT	6
SECTION 2 - PRODUCT DESCRIPTION	9
GENERAL SYSTEM DESCRIPTION	9
SEMI-HERMETIC YORK TWIN-SCREW COMPRESSORS	11
EVAPORATOR	11
CONDENSER	11
REFRIGERANT CIRCUIT	11
ELECTRICAL	11
BUILDING AUTOMATION SYSTEM CAPABILITIES	12
MICROCOMPUTER CONTROL CENTER	12
ACCESSORIES AND OPTIONS	13
SECTION 3 - HANDLING AND STORAGE	16
DELIVERY AND STORAGE	16
INSPECTION	16
MOVING THE CHILLER	16
LIFTING WEIGHTS	16
LIFTING UNIT	17
UNIT REMOVAL FROM SHIPPING CONTAINER	18
LIFTING USING LUGS	19
LIFTING USING SHACKLES	19
Introduction of field site assembling process of the main and auxiliary unit	20
SECTION 4 - INSTALLATION	23
LOCATION REQUIREMENTS	23
OUTDOOR INSTALLATIONS	23
LOCATION CLEARANCES	23
VIBRATION ISOLATORS	24
SHIPPING BRACES	24
CHILLED LIQUID PIPING General Requirements	24
WATER TREATMENT	25
PIPEWORK ARRANGEMENT	26
MINIMUM WATER VOLUME	26
FLOW RATE OUT OF RANGE	26
LEAVING WATER TEMPERATURE OUT OF RANGE	26
VARIABLE PRIMARY FLOW	27
THERMAL STORAGE	27
CONNECTION TYPES AND SIZES	27
COOLER CONNECTIONS	27
ELECTRICAL CONNECTION	28
POWER WIRING	28
POWER SUPPLY WIRING	28
115VAC CONTROL SUPPLY TRANSFORMER	29
CONTROL WIRING	29
VOLTS FREE CONTACTS	29
SYSTEM INPUTS	29
POWER SUPPLY WIRING	30

CUSTOMER CONTROL WIRING.....	31
SECTION 5 - TECHNICAL DATA	35
NOMENCLATURE.....	35
DIMENSIONS.....	42
PREPARATION.....	64
SECTION 6 - COMMISSIONING.....	64
FIRST TIME START.....	67
OPERATING CONTROLS	68
SECTION 7 - OPERATION	68
BASIC OPERATING SEQUENCE.....	70
UNIT WARNING	70
UNIT SAFETIES.....	71
SYSTEM SAFETIES (FAULTS)	72
SECTION 8 - MICROPANEL STATUS KEY	77
Status Key Operation	77
UNIT DATA KEY	80
SYSTEM DATA KEYS 1 THROUGH 4	82
VSD DATA KEY	85
OPERATING HOURS / START COUNTER KEY	86
HISTORY KEY	87
SETPOINTS KEY.....	94
PROGRAM KEY	96
OPTIONS KEY.....	99
DATE/TIME AND SCHEDULE KEYS.....	102
MANUAL OVERRIDE KEY.....	105
SYSTEM SWITCHES KEY	109
GENERAL REQUIREMENTS	110
SECTION 9 - MAINTENANCE.....	110
REFRIGERANT REMOVAL, EVACUATION AND CHARGING A YVAA CHILLER.....	111
MICROCHANNEL COIL CLEANING.....	112
MAINTENANCE REQUIREMENTS FOR YVAA CHILLERS.....	113
CHILLED LIQUID AND SUCTION TEMPERATURE SENSOR INPUT VOLTAGE.....	117
WATER TREATMENT	121
SECTION 10 - DECOMMISSIONING, DISMANTLING AND DISPOSAL	122
GENERAL	122

LIST OF FIGURES

FIGURE 1 YVAA AIR-COOLED SCREW LIQUID CHILLER WITH VARIABLE SPEED DRIVER	9
FIGURE 2-CHILLER CONTROL SYSTEM.....	10
FIGURE 3- VIEW OF YORK CONTROL CENTER.....	12
FIGURE 4- PORPER LIFTING OF YVAA CHILLER.....	17
FIGURE 5-YVAA MAIN AND AUXILIARY UNIT ASSEMBLY IN FIELD.....	21
FIGURE 6-ACCEPTABLE MINIMUM CELARANCES AROUND/BETWEEN UNITS (S).....	23
FIGURE 7- PIPEWORK ARRANGEMENT	26
FIGURE 8- LEAVING WATER TEMPERATURE OUT.....	26
FIGURE 9- SUGGESTED LAYOUT FOR APPLICATIONS WITH A FLOW RATE LESS THAN THE EVAPORATOR MINIMUM ALLOWABLE FLOW RATE	26
FIGURE 10- SUGGESTED LAYOUT FOR APPLICATIONS WITH A FLOW RATE GREATER THAN THE EVAPORATOR MAXIMUM ALLOWABLE FLOW RATE.....	27
FIGURE 11 – FLANGE SKETCH.....	27
FIGURE 12- VICTAULIC GROOVE	28
FIGURE 13- POWER CONNECTIONS.....	30
FIGURE 14- CUSTOMER CONTROL CONNECTIONS.....	31
FIGURE 15- DIMENSIONS	42
FIGURE 16- KEYBOARD AND DISPLAY.....	68

LIST OF TABLES

TABLE 1- MINIMUM EVAPORATOR TUBE	24
TABLE 2- COOLER FLANGE DIMENSIONS.....	27
TABLE 3 - ELECTRICAL DATA - STANDARD AND ULTRA QUIET CONDENSER FANS.....	32
TABLE 4- ELECTRICAL DATA - HIGH AIRFLOW/HIGH STATIC CONDENSER FANS	33
TABLE 5- PHYSICAL DATA (ENGLISH)	36
TABLE 6- PHYSICAL DATA (SI).....	39
TABLE 7- DIMENSIONS.....	44
TABLE 8- RIGGING HOLE LOCATIONS (ENGLISH)	46
TABLE 9- RIGGING HOLE LOCATIONS (SI).....	49
TABLE 10- ISOLATOR LOCATIONS (ENGLISH).....	52
TABLE 11- ISOLATOR LOCATIONS (SI)	55
TABLE 12- LOW DIFFERENTIAL OIL PRESSURE CUTOUT	74
TABLE 13 - START INHIBIT SENSOR THRESHOLDS.....	75
TABLE 14- SENSOR MIN/MAX OUTPUTS	84
TABLE 15- SETPOINT LIMITS	95
TABLE 16- PROGRAMMABLE OPERATING PARAMETERS.....	98
TABLE 17- PRINTOUT TYPES.....	106
TABLE 18- TROUBLESHOOTING GUIDE	114
TABLE 19- TEMPERATURE INPUT VOLTAGE SENSORTABLE.....	117
TABLE 20- OUTSIDE AIR TEMPERATURE SENSOR INPUT VOLTAGE	118
TABLE 21- PRESSURE TRANSDUCER OUTPUT VOLTAGE.....	119
TABLE 22- MOTOR TEMPERATURE SENSOR RESISTANCE.....	120
TABLE 23- COOLER WATER QUALITY REQUIREMENT.....	121

SECTION 1 - GENERAL CHILLER INFORMATION AND SAFETY

1

INTRODUCTION

YORK YVAA chillers are manufactured to the highest design and construction standards to ensure high performance, reliability and adaptability to all types of air conditioning installations.

The unit is intended for cooling water or glycol solutions and is not suitable for purposes other than those specified in this manual.

This manual contains all the information required for correct installation and commissioning of the unit, together with operating and maintenance instructions. The manual should be read thoroughly before attempting to operate or service the unit.

All procedures detailed in the manual, including installation, commissioning and maintenance tasks must only be performed by suitably trained and qualified personnel.

The manufacturer will not be liable for any injury or damage caused by incorrect installation, commissioning, operation or maintenance resulting from a failure to follow the procedures and instructions detailed in the manual.

WARRANTY

Johnson Controls warrants YVAA chillers in accordance with the "Limited Warranty Engineered Systems Equipment" procedure, Form 50.05-NM2.

Johnson Controls warrants all equipment and materials against defects in workmanship and materials for a period of eighteen months from date of shipment or 12 months from date of startup, whichever comes first, unless labor or extended warranty has been purchased as part of the contract.

The warranty is limited to parts only replacement and shipping of any faulty part, or sub-assembly, which has failed due to poor quality or manufacturing errors. All claims must be supported by evidence that the failure has occurred within the warranty period, and that the unit has been operated within the designed parameters specified.

All warranty claims must specify the unit model, serial number, order number and run hours/starts. Model and serial number information is printed on the unit identification plate.

The unit warranty will be void if any modification to the unit is carried out without prior written approval from Johnson Controls.

For warranty purposes, the following conditions must be satisfied:

- The initial start of the unit must be carried out by trained personnel from an authorized Johnson Controls Service Center. Refer to *SECTION 6 - COMMISSIONING on Page 59* for more information.
- Only genuine YORK approved spare parts, oils, coolants, and refrigerants must be used.
- All the scheduled maintenance operations detailed in this manual must be performed at the specified times by suitably trained and qualified personnel. See *SECTION 9 - MAINTENANCE on Page 107* for more information.
- Failure to satisfy any of these conditions will automatically void the warranty. Refer to Form 50.05-NM2 for complete details.

QUALITY ASSURANCE AND SAFETY

YVAA chillers are designed within EN ISO 9001 and built within an EN ISO 9002 accredited manufacturing organization.

Units conform with the following Standard:

- GB5226.1 Safety of machinery- Electrical equipment of machines – Part 1: General requirements.
- GB25131 Safety requirements for water chiller(heat pump) using the vapor compression cycle.
- GB18430.1 Water chilling (heat pump) package using the vapor compression cycle Part 1: Water chilling (heat pump) package for industrial & commercial and similar application.
- AHRI550/590 Water Chilling Packages Using the Vapor Compression Cycle.

FLUORINATED GREENHOUSE GASES

- This equipment contains fluorinated greenhouse gases covered by the Kyoto Protocol.
- The global warming potential of the refrigerant (R134a) used in this unit is 1300.
- The refrigerant quantity is stated in *Table 4 on Page 38* of this document.
- The fluorinated greenhouse gases in this equipment may not be vented to the atmosphere.

- This equipment should only be serviced by qualified technicians.

RESPONSIBILITY FOR SAFETY

Every care has been taken in the design and manufacture of the unit to ensure compliance with the safety requirements listed above. However, the individual operating or working on any machinery is primarily responsible for:

- Personal safety, safety of other personnel, and the machinery.
- Correct utilization of the machinery in accordance with the procedures detailed in the manual.

ABOUT THIS MANUAL

The contents of this manual include suggested best working practices and procedures. These are issued for guidance only, and they do not take precedence over the above stated individual responsibility and/or local safety regulations.

This manual and any other document supplied with the unit are the property of Johnson Controls which reserves all rights. They may not be reproduced, in whole or in part, without prior written authorization from an authorized Johnson Controls representative.

MISUSE OF EQUIPMENT

Suitability for Application

The unit is intended for cooling water or glycol solutions and is not suitable for purposes other than those specified in these instructions. Any use of the equipment other than its intended use, or operation of the equipment contrary to the relevant procedures may result in injury to the operator, or damage to the equipment.

The unit must not be operated outside the design parameters specified in this manual.

Structural Support

Structural support of the unit must be provided as indicated in these instructions. Failure to provide proper support may result in injury to the operator, or damage to the equipment and/or building.

Mechanical Strength

The unit is not designed to withstand loads or stresses from adjacent equipment, pipework or structures. Additional components must not be mounted on the unit. Any such extraneous loads may cause structural

failure and may result in injury to the operator, or damage to the equipment.

General Access

There are a number of areas and features, which may be a hazard and potentially cause injury when working on the unit unless suitable safety precautions are taken. It is important to ensure access to the unit is restricted to suitably qualified persons who are familiar with the potential hazards and precautions necessary for safe operation and maintenance of equipment containing high temperatures, pressures and voltages.

Pressure Systems

The unit contains refrigerant vapor and liquid under pressure, release of which can be a danger and cause injury. The user should ensure that care is taken during installation, operation and maintenance to avoid damage to the pressure system. No attempt should be made to gain access to the component parts of the pressure system other than by suitably trained and qualified personnel.

Electrical

The unit must be grounded. No installation or maintenance work should be attempted on the electrical equipment without first switching power OFF, isolating and locking-off the power supply. Servicing and maintenance on live equipment must not be attempted. No attempt should be made to gain access to the control panel or electrical enclosures during normal operation of the unit.

Rotating Parts

Fan guards must be fitted at all times and not removed unless the power supply has been isolated. If ductwork is to be fitted, requiring the wire fan guards to be removed, alternative safety measures must be taken to protect against the risk of injury from rotating fans.

Sharp Edges

The fins on the air-cooled condenser coils have sharp metal edges. Reasonable care should be taken when working in contact with the coils to avoid the risk of minor abrasions and lacerations. The use of gloves is recommended.

Frame rails, brakes, and other components may also have sharp edges. Reasonable care should be taken when working in contact with any components to avoid risk of minor abrasions and lacerations.

Refrigerants and Oils

Refrigerants and oils used in the unit are generally nontoxic, non-flammable and non-corrosive, and pose no special safety hazards. Use of gloves and safety glasses is, however, recommended when working on the unit. The buildup of refrigerant vapor, from a leak for example, does pose a risk of asphyxiation in confined or enclosed spaces and attention should be given to good ventilation.

High Temperature and Pressure Cleaning

High temperature and pressure cleaning methods (e.g. steam cleaning) should not be used on any part of the pressure system as this may cause operation of the pressure relief device(s). Detergents and solvents, which may cause corrosion, should also be avoided.

Emergency Shutdown

In case of emergency, the control panel is fitted with an incoming supply circuit breaker with a red and yellow handle which can be used as the emergency stop device. When operated it removes the electrical supply to the inverter, fans, and control circuit thus shutting down the unit.

Safety Labels



White symbol on blue background.

For safe operation, read the Instructions first.



Black symbol on yellow background.

Warning: This machine may start automatically without prior warning



Black symbol on yellow background.

Warning: Hot surface.



Black symbol on yellow background.

Warning: Safety relief valve may discharge gas or liquid without prior warning.



Black symbol on yellow background.

Warning: Isolate all electrical sources of supply before opening or removing the cover, as lethal voltages may exist.



Black symbol on yellow background.

General attention symbol.

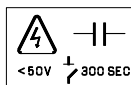

Black symbol on yellow background.

Warning: On isolating the supply it may take up to 300 seconds for the capacitor voltage to fall below 50 volts.

THIS PAGE INTENTIONALLY LEFT BLANK

SECTION 2 - PRODUCT DESCRIPTION

2



LD15045

FIGURE 1 YVAA AIR-COOLED SCREW LIQUID CHILLER WITH VARIABLE SPEED DRIVER

GENERAL SYSTEM DESCRIPTION

YORK YVAA R134a chillers are designed for water or glycol cooling. All units are designed to be located outside on the roof of a building or at ground level.

The units are completely assembled with all interconnecting refrigerant piping and internal wiring, ready for field installation.

Prior to delivery, the unit is pressure tested, evacuated, and fully charged with refrigerant and oil in each of the two independent refrigerant circuits. After assembly, an operational test is performed with water flowing through the cooler to ensure that each refrigerant circuit operates correctly.

Unit Structure is manufactured from heavy gauge structural painted galvanized steel/hot rolled steel. Many external structural parts are coated with “Champagne” baked-on enamel powder paint. This provides a finish which, when subjected to 400 hours salt spray testing in accordance with rating 1 according to GB10125.

All exposed power wiring is routed through liquid-tight, non-metallic conduit.

The YVAA Chiller combines the best of modern screw compressor design with the latest technology in variable speed drives. The result is superior control and efficiency in real world conditions. The VSD enables slowing the speed of the compressor to match the load on the system resulting in precise chilled liquid control, minimized sound, maximum energy efficiency, and reduced cost of ownership. The VSD also provides soft starts with no electrical inrush. The lack of heat build-up on start also enables required off time between starts to be reduced to a period of two minutes.

The YVAA Air-Cooled Screw Chiller utilizes many components, which are the same or nearly the same as a standard screw chiller of a similar size. This includes modular frame rails, condenser, fans, compressors and evaporator.

The chiller consists of two screw compressors in a corresponding number of separate refrigerant circuits, a hybrid falling film evaporator, an air-cooled condenser, receiver/flash tanks, feed valves, oil separators, and compressor mufflers. Oil separators utilize no moving parts and are rated for a 31 barg (450 PSIG) design working pressure. Oil cooling is accomplished by refrigerant leaving the eductor flashing in the suction line which cools the oil, motor and compressor.

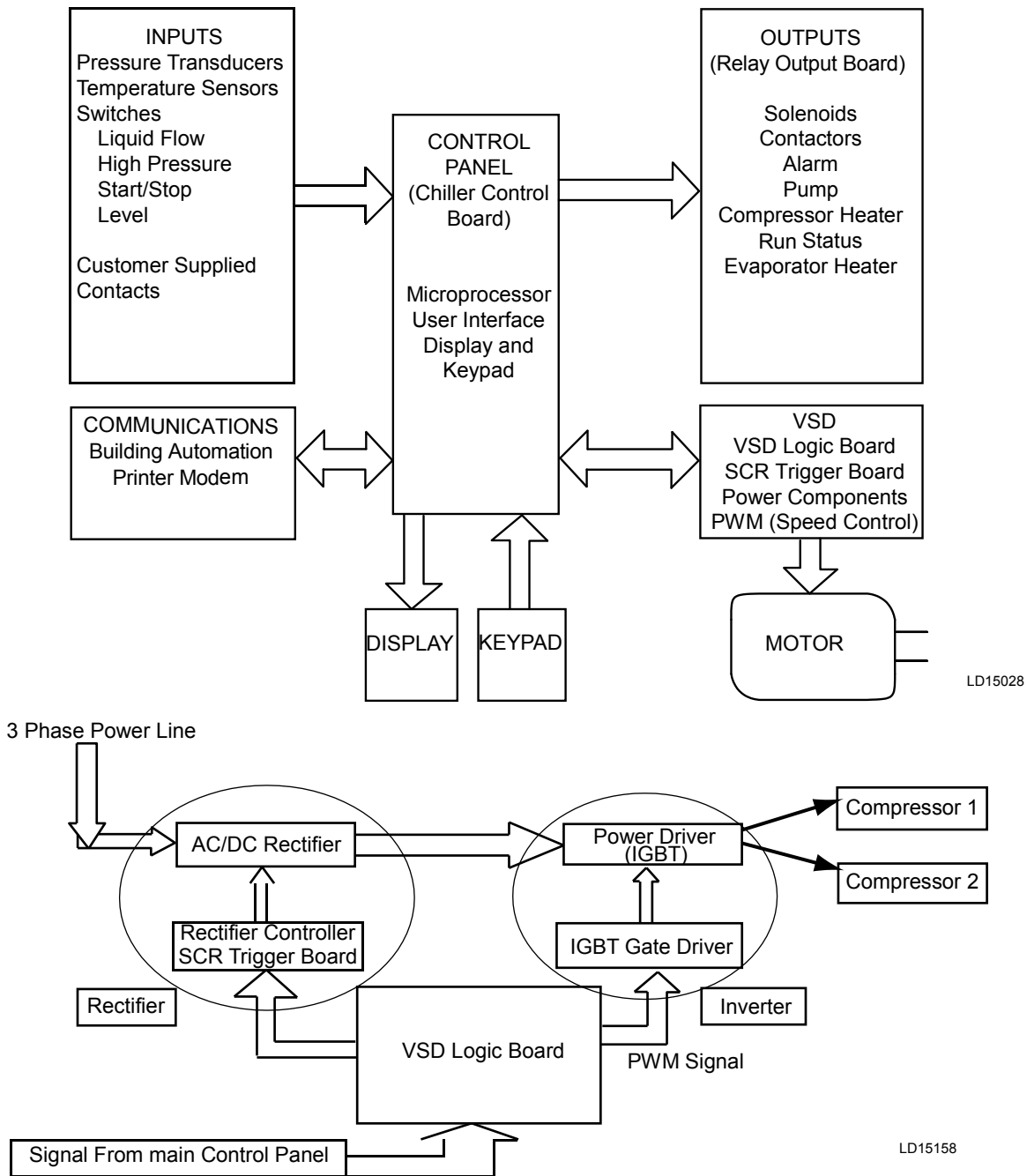

FIGURE 2–CHILLER CONTROL SYSTEM

An integral liquid cooled, transistorized, PWM, Variable Speed Drive (VSD) is controlled by the chiller microprocessor control panel to start/stop, select compressors to run, and select compressor speed. Displacement Power Factor is 95% at part or full load.

The chiller microprocessor communicates with the VSD Logic Board via a 3-wire RS-485 opto coupled data link. The VSD Logic Board runs the number of compressors required to meet the load and the compressors to the speed requested by the chiller microprocessor.

The basic system control and VSD system architecture is shown in Figure 2.

SEMI-HERMETIC YORK TWIN-SCREW COMPRESSORS

Compressors are direct drive, semi-hermetic, rotary twin-screw type, including: muffler, temperature actuated „off-cycle“ heater, IP55 terminal board and precision machined cast iron housing.

Reliable suction gas cooled, high efficiency, accessible hermetic compressor motor, full suction gas flow through mesh screen filter, with inherent internal thermal overload protection and external current overload on all three phases.

Continuous function, microprocessor controlled, Variable Speed Drive (VSD) shall provide valve-less, smooth capacity control from 100% down to 10% of chiller capacity.

In addition, elimination of the slide valve and associated unloading components has resulted in a 50% reduction in compressor moving parts.

EVAPORATOR

The evaporator is a shell and tube, hybrid falling film type heat exchanger. It contains a balance of flooded and falling film technology to optimize efficiency, minimize refrigerant charge, and maintain reliable control. A specifically designed distribution system provides uniform refrigerant flow for optimum performance.

CONDENSER

The YVAA introduces micro-channel coil to the York screw compressor chiller line. The micro-channel maximizes condenser heat transfer, resulting in a smaller footprint, and reduces refrigerant charge by as much as 50%.

Each condenser coil is a single piece all aluminum construction including headers, tubes and fins to avoid galvanic corrosion due to dissimilar metals. Coils and headers are brazed as one piece. Integral sub-cooling is included. The design working pressure is 43bar.

Multiple, standard low sound, high efficiency, TEAO motor driven fans move air through the coils. They are dynamically and statically balanced, direct drive with corrosion-resistant glass fiber reinforced composite blades molded into low-noise, full airfoil cross sections, providing vertical air discharge from extended orifices for efficiency and low sound.

Fan motors are Totally Enclosed Air-Over (TEAO), squirrel-cage type and current protected. The direct

drive motors feature double-sealed and permanently lubricated ball bearings, cutting down on maintenance cost over the life of the unit.

REFRIGERANT CIRCUIT

An independent refrigerant circuit is provided per compressor. Each circuit uses copper refrigerant pipe formed on computer controlled bending machines to reduce the number of brazed joints resulting in a reliable and leak resistant system.

- Discharge lines are provided with a manual compressor shutoff service valve (See *Accessories and Options on Page 17* for suction line service valve).
- The external oil separators, with no moving parts and designed for minimum oil carry-over, are mounted in the discharge line of the compressor.
- Liquid line components include: high absorption removable core filter-drier, sight glasses with moisture indicators, manual shut-off valve with charging port, orifice and electronic expansion valve.
- An economizer (flash) tank is located in each refrigerant circuit to increase the system efficiency.

ELECTRICAL

YORK has over 25 years of experience designing variable -speed drives specifically for chiller applications. The result is an extremely reliable air-cooled chiller system that offers industry leading efficiency at real world operating conditions, valve-less compressor loading/unloading, excellent capacity control, high power factor and soft start..

Incoming single point power is standard utilizing a lockable circuit breaker, 115VAC control transformer, VSD, fan contactors, ON/OFF unit switch, microcomputer keypad and display, Chiller Control and VSD Logic boards, and relay boards.

Standard design includes IP55 rating, powder painted steel cabinet with hinged, latched, and gasket sealed outer doors equipped with wind struts for safer servicing. The panel includes a control display access door so that display and control features can be accessed without opening main cabinet doors.

All exposed power wiring is routed through liquid-tight, UV-stabilized, non-metallic conduit.

BUILDING AUTOMATION SYSTEM CAPABILITIES

The E-Link Gateway provides an economical and versatile connection between York equipment and open/standard protocols. It efficiently manages the communication protocols currently used by York equipment, exposing the data in a consistent, organized, and defined fashion. The E-Link Gateway is available as a field-installed option on YVAA. A simple switch selection allows configuration of the required equipment profile and output protocol, which reduces equipment connectivity startup time.

MICROCOMPUTER CONTROL CENTER

The microcomputer control center (see *Figure 3 on Page 16*) provides automatic control of chiller operation including compressor start/ stop and load/unload anti-recycle timers, condenser fans, evaporator pump, evaporator heater, unit alarm contacts and run signal contacts. The microcomputer control center comes online as soon as the main power switch on the unit is switched on; immediately, the microcomputer control center will begin to check all variables with a frequency ranging from 30 seconds to almost continuous monitoring.

The microprocessor controls the unit's capacity by matching the actual leaving chilled water temperature (LCWT) to the user-defined setpoint. Factors that may cause the system's actual LCWT to fluctuate are changes in ambient temperature, loop flow rate, load, and loop volume. The control system reacts to such changes by adjusting the number of compressors that are on and the loading of each compressor in order to keep the LCWT at the setpoint.

The control system logic monitors the rate at which the LCWT is approaching the setpoint to ramp up or down compressor capacity as required. The variable frequency drive allows the compressor capacity to match the load.

Display Data

- Leaving Chilled Liquid Temperature
- Returning Liquid Temperature
- Ambient Temperature
- Lead System
- Compressor Capacity (% of Full Load Amps)
- VSD Output Frequency / Compressor Speed
- Compressor Run Hours

- Compressor Number of Starts
- Oil Pressure and Temperature (per Compressor)
- Evaporator Pump Status
- Evaporator Heater Status
- History Data for Last Twenty Normal Shutdowns
- History Data for Last Ten Shutdown Faults

Programmable Setpoints

- Chiller On/Off
- Chilled Liquid (Water or Glycol)
- Local or Remote Control
- Units of Measure (Imperial or SI)
- System Lead / Lag
- Remote Temperature Reset
- Remote Current Limit

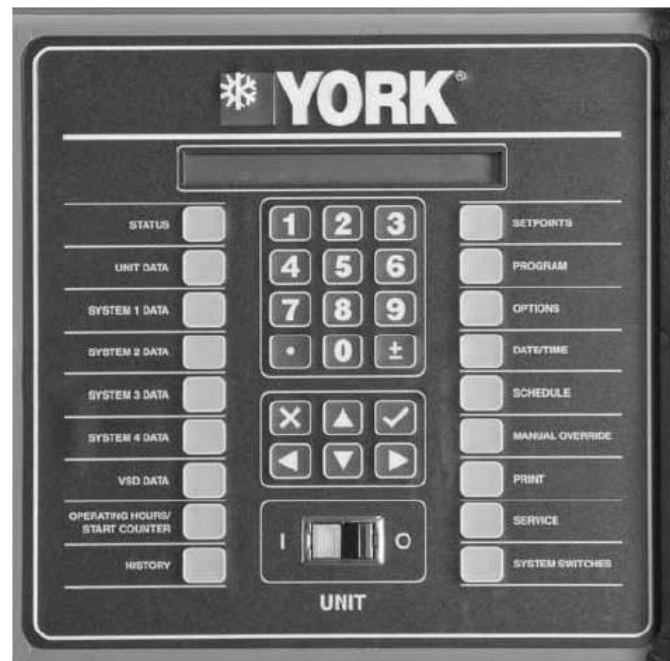

FIGURE 3- VIEW OF YORK CONTROL CENTER

- Leaving Chilled Liquid Temperature Setpoint and Range

Johnson Controls' systems or another vendor's systems can incorporate these setpoints and data outputs to give the customer a complete understanding of how the system is running through a Building Automation System.

Extreme Conditions - During extreme or unusual conditions (i.e. blocked condenser coils, ambient above scheduled maximum, etc.) the chiller control system will avoid shutdown by varying capacity. By monitoring motor current and suction and discharge pressures, the chiller can maintain maximum available cooling output without shutting down.

Unit Safeties are provided for the chiller to perform auto-reset shut down for the following conditions:

- Ambient temperature above or below allowable range
- Out of range leaving chilled liquid temperature
- Under voltage
- Flow switch operation

ACCESSORIES AND OPTIONS

All options factory mounted unless otherwise noted.

SOUND ATTENUATION

Low Noise Kits – The chiller configuration is equipped with low sound fans and acoustic treatments on the refrigerant lines and compressors. There are several sound attenuation options available to further reduce sound at its source thereby meeting local sound level regulations.

SilentNight™ - Due to time of day based sound regulations in some locations it may be desirable to force the chiller to a lower sound level on demand. The SilentNight control option provides a control input to limit sound output of the chiller based on time of day. This feature is programmable at the chiller panel or can be controlled remotely via a signal (4-20mA or 0-10VDC) from a BAS system.

FAN OPTIONS

Ultra Quiet Fans – The chiller is equipped with specially designed fans and motors to provide lower sound levels yet retain appropriate airflow. The result is reduced fan generated sound with minimal effect on the chiller capacity or efficiency.

High Static Fans - The chiller is equipped with condenser fans with higher power motors suitable for high external static pressure, up to 100 Pa (0.4 in. water), across condenser coils. This option should be selected if additional airflow resistance may be present due to flow restrictions such as field installed ducts, filters, sound enclosures etc. Please contact your local JCI representative for more information.

High Airflow Fans - The chiller is equipped with condenser fans with airfoil type blades and high power motors providing extra airflow across coils. In some chiller configurations, this option can provide an increase in chiller capacity at high ambient. The high 2 airflow fans are also available with variable speed control. Please contact your local JCI representative for more information.

CONDENSER COIL PROTECTION

The aluminum alloys used in the YVAA micro-channel condenser have been carefully selected and tested for high corrosion resistance. However, all metals can corrode in harsh conditions. Consider protecting coils from corrosive environments such as coastal, marine, urban and industrial.

Post-Coated Epoxy Dipped Condenser - Micro-channel condenser coils applied with electro-deposited and baked flexible epoxy coating that is finished with a polyurethane UV resistant top-coat suitable for highly corrosive applications.

PROTECTIVE CHILLER PANELS

Wire Panels – UV stabilized black polyvinyl chloride coated, heavy gauge, welded wire mesh guards mounted on the exterior of the full unit. Protects condenser coil faces and prevents unauthorized access to refrigerant components (compressors, pipes, evaporator, etc.), yet provides free air flow. This can cut installation cost by eliminating the need for separate, expensive fencing.

Louvered Panels – Louvered panels, painted the same color as the unit, enclose the unit to visually screen and protect the coils as well as preventing unauthorized access to internal components. Also available as a condenser-only option.

Louvered/Wire Panels Combination - Louvered panels, painted the same color as the unit, are mounted on external condenser coil faces. Heavy gauge, welded wire-mesh panels, coated to resist corrosion, are mounted around base of machine to restrict unauthorized access.

End Hail Guard – Louvered panels, painted the same color as the unit, are installed on the rear of the unit (opposite end of the control panel) to protect the exposed condenser from flying debris or hail.

V-Guard Panels – Solid panels, painted the same color as the unit, are installed along the sides of the units to cover exposed piping within the condenser section without impacting airflow. These guard panels can be combined with End Hail Guard option for additional protection from debris.

EVAPORATOR OPTIONS

38 mm insulation – Double thickness insulation provided.

Connection Location - The standard unit configuration is available with fluid inlet connections at rear (opposite control panel end) of unit. Option available for front fluid inlet on select configurations.

Water Box Heater - The standard unit comes with freeze protection on the evaporator down to -17.8°C (0 °F) with equipped evaporator shell heater band. The water box heater option provides additional freeze protection down to -28°C (-20°F).

CONTROLS OPTIONS

High Ambient Operation – This provides special control logic coupled with high airflow fans to permit high ambient (up to 55°C (130°F)) operation. Fans are airfoil type blades with high power motors. This option may also allow for increased machine capacity, allowing the selection of a smaller chassis to meet specific capacity requirements.

Building Automation System Interface (Temperature) - Factory installed option to accept a 4 to 20mA or a 0 to 10VDC input to allow remote reset of the Leaving Chilled Liquid Temperature Setpoint. The setpoint can be positively offset upwards up to 22.2°C (40°F). This option is useful for ice storage or process applications or for periods where higher chilled liquid temperatures are adequate for low loads. Available alone or in combination with BAS Load Limit.

Building Automation System Interface (Load Limit) - Factory installed option to accept a 4 to 20mA or a 0 to 10VDC input to allow remote reset of the Load Limit Setpoint. The setpoint can limit system demand from 30-100%. Available alone or in combination with BAS Temperature Reset.

E-Link – The E-Link gateway provides communication or Building Automation Systems, including BACnet (MS/TP), Modbus, LON and N2.

Thermal Storage – Provides special control logic and modifications to produce leaving chilled brine temperatures below 4.4°C (40°F) primarily at times of low ambient temperatures (night time). Option can be used to produce ice to supplement cooling and significantly decrease energy costs. The capability of the chiller is enhanced by using both ice and chilled water simultaneously during times of peak cooling needs.

GENERAL OPTIONS

Flow Switch Accessory - Vapor proof SPDT, IP55

switch, 103 barg (150 PSIG) DWP, -29°C to 121°C (-20°F to 250°F) with 1" NPT connection for upright mounting in horizontal pipe (This flow switch or equivalent must be furnished with each unit). **Field mounted.**

Differential Pressure Switch – This 0.2-2 barg (3-29 PSIG) range switch, with 1/4" NPT pressure connections, is an alternative to the paddle-type flow switch. **Field mounted.**

Service Isolation Valve – Service suction isolation valve added to unit for each refrigerant circuit.

Dual Pressure Relief Valve – Two safety relief valves are mounted in parallel; one is always operational to assist in valve replacement during maintenance.

Terminal Block –Terminal Block connections shall be provided at the point of incoming single point connection for field connection and interconnecting wiring to the compressors. Separate external protection must be supplied, by others, in the incoming power wiring, which must comply with local codes.

Circuit Breaker – A unit-mounted circuit breaker with external lockable handle will be supplied to isolate the single point power voltage for servicing. The circuit breaker is sized to provide motor branch circuit protection, short circuit protection and ground fault protection for the motor branch-circuit conductors, the motor control apparatus and the motors.

Non-Fused Disconnect Switch – Unit-mounted disconnect switch with external lockable handle can be supplied to isolate the unit power voltage for servicing. Separate external fusing must be supplied by the power wiring, which must comply with local codes.

VIBRATION ISOLATION

Elastomeric Isolation – This option is recommended for normal installations. It provides very good performance in most applications for the least cost. **Field mounted.**

Spring Isolators – Spring and cage type isolators for mounting under the unit base rails are available to support unit. They are level adjustable. 25 mm (1") nominal deflection may vary slightly by application. **Field mounted.** For chiller installed on a suitable rooftop location, Spring Isolators are recommended.

50 mm (2") Restrained Spring Isolators – Restrained Spring-Flex Mounting isolators incorporate a rugged welded steel housing with vertical and horizontal limit stops. The deflection may vary slightly by application.

They are level adjustable. **Field mounted.**

SECTION 3 - HANDLING AND STORAGE

DELIVERY AND STORAGE

To ensure consistent quality and maximum reliability, all units are tested and inspected before leaving the factory. Units are shipped completely assembled and containing refrigerant under pressure. Units are shipped without export crating unless crating has been specified on the Sales Order.

If the unit is to be put into storage, prior to installation, the following precautions should be observed:

- The chiller must be “blocked” so that the base is not permitted to sag or bow.
- Ensure that all openings, such as water connections, are securely capped.
- Do not store YVAA chiller where exposed to ambient air temperatures exceeding 43°C (110°F).
- Do not store YVAA chiller where exposed to ambient air temperature lower than -28°C (-20°F)
- The condensers should be covered to protect the coils and fins from potential damage and corrosion, particularly where building work is in progress.
- The unit should be stored in a location where there is minimal activity in order to limit the risk of accidental physical damage.
- To prevent inadvertent operation of the pressure relief devices the unit must not be steam cleaned.
- It is recommended that the unit is periodically inspected during storage.

INSPECTION

Remove any transit packing and inspect the unit to ensure that all components have been delivered and that no damage has occurred during transit. If any damage is evident, it should be noted on the carrier’s freight bill and a claim entered in accordance with the instructions given on the advice note.

Major damage must be reported immediately to your local Johnson Controls representative.

MOVING THE CHILLER

Prior to moving the unit, ensure that the installation site is suitable for installing the unit and is easily capable of supporting the weight of the unit and all associated services.

The units are designed to be lifted using cables. A spreader bar or frame should be used in order to prevent damage to the unit from the lifting chains.

Units are provided with lifting eyes in the sides of the base frame, which can be attached directly using shackles or safety hooks (see *Figure 4 on Page 20* for proper lifting illustration).



The unit must only be lifted by the base frame at the points provided. Never move the unit on rollers, or lift the unit using a forklift truck.

Care should be taken to avoid damaging the condenser cooling fins when moving the unit.

LIFTING WEIGHTS

For details of weights and weight distribution, refer to the data shipped in the chiller information packet and unit nameplate.

LIFTING UNIT

Use spreader bars to avoid lifting chains hitting the chiller. Various methods of spreader bar arrangements may be used; keeping in mind the intent is to keep the unit stable and to keep the chains from hitting the chiller and causing damage.

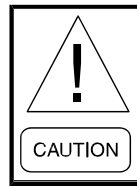

Never lift the chiller using a forklift or by hooking to the top rails. Use only the lifting holes provided.

Lifting instructions are placed on a label on the chiller and on the shipping bag.



FIGURE 4- PORPER LIFTING OF YVAA CHILLER

UNIT REMOVAL FROM SHIPPING CONTAINER

1. Place a clevis pin into the holes provided at the end of each base rail on the unit. Attach chains or nylon straps through the clevis pins and hook onto a suitable lift truck for pulling the unit out of the container.(chain shown)
2. Slowly place tension on the chains or straps until the unit begins to move and then slowly pull the unit from the container. Be sure to pull straight so the sides do not scrape the container.
3. Place a lifting fixture on the forks of the lift truck and reattach the chain or strap. Slightly lift the front of the unit to remove some weight from the floor of the container. Continue pulling the unit with an operator on each side to guide the lift truck operator.
4. Pull the unit until the lifting locations are outside of the container. Place 4 X 4 blocks of wood under the base rails of the unit. Gently rest the unit on the blocks and remove the chains and lift truck.
5. Attach lifting rigging from the crane and slowly complete the removal from the container then lift up and away.



LIFTING USING LUGS

Units are provided with lifting holes in the base frame which accept the accessory lifting lug set (show below).

The lugs (RH and LH) should be inserted into the respective holes in the base frame and turned so that the spring loaded pin engages into the hole and the flanges on the lug lock behind the hole. The lugs should be attached to the cables/chains using shackles or safety hooks.

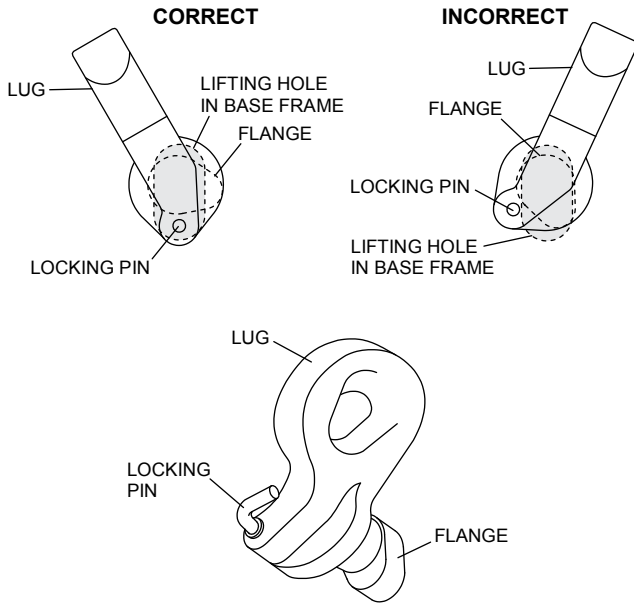

may be used, keeping in mind the intent is to keep the unit stable and to keep the chains from hitting the chiller and causing damage..

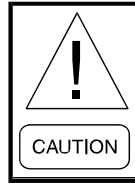

Never lift the chiller using a forklift or by hooking to the top rails. Use only the lifting holes provided.

Lifting Instructions are placed on a label on the chiller and on the shipping bag.



LIFTING USING SHACKLES

The shackles should be inserted into the respective holes in the base frame and secured from the inside.

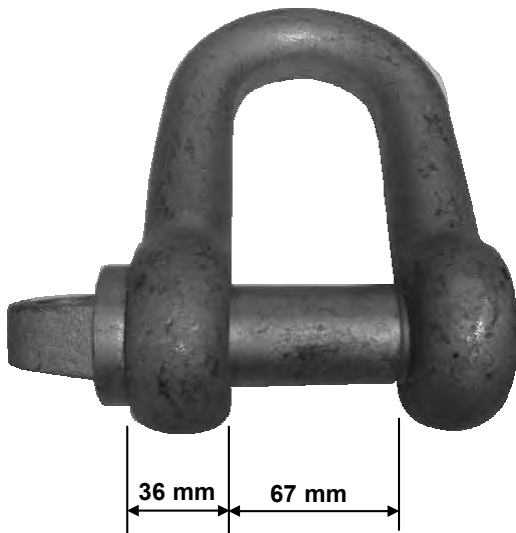

Use spreader bars to avoid lifting chains hitting the chiller. Various methods of spreader bar arrangements



INTRODUCTION OF FIELD SITE ASSEMBLING PROCESS OF THE MAIN AND AUXILIARY UNIT

The System2 of YVAA0443,0483 and 0523 are divided into 2 pieces(main unit and auxiliary unit) for the convenience of transport, the factory will ship the main unit and auxiliary unit separately, which assembled a whole unit in the field site.

All the refrigerant and oil of system 2 have been charged into the system 2 of the main unit, the auxiliary unit locked by ball valve has just been kept positive pressure with R134a .

Please follow below steps to assemble the main and auxiliary unit in the field site.

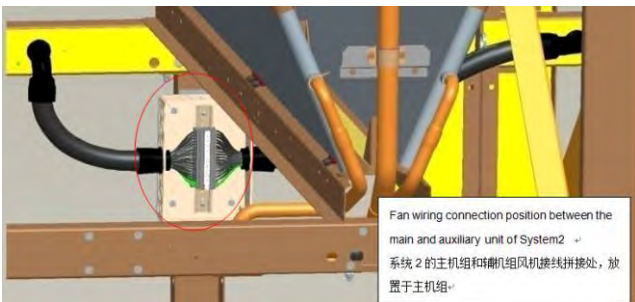
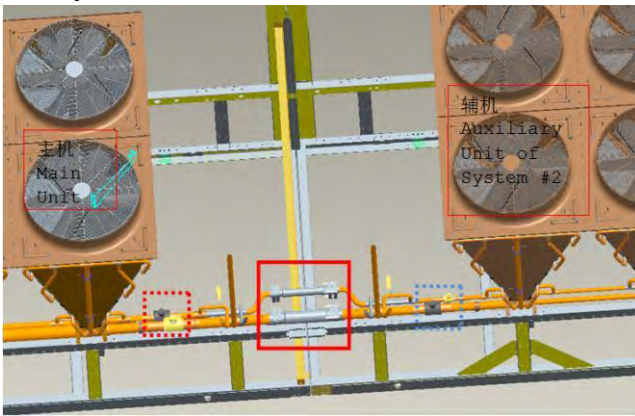

1, Before connect the flexible pipe between liquid line flanges and discharge line flange together (shown in square line between units). First lift Main unit and put main unit sitting at the correct position with isolators located, and lift auxiliary unit and put auxiliary unit sitting at the correct position with isolators located. And then well adjust three dimensional position (height adjust by isolator, chiller length dimension and chiller width dimension adjust by lifting process) to ensure flange kit can be aligned together.

2, Keep discharge line ball valves and liquid line ball valves, total 4 pieces of valves used for filed site connection purpose tightly close(shown in dashed square line). After isolated these four valve, for system #2 of main unit, one Coil VEEs can be isolated; for

auxiliary unit of system #2, one Coil VEEs can be isolated. At next procedure, the refrigerant inside this One Coil VEEs for each unit shall be reclaimed.

3, There are four charge valves located between flanges and ball valves, reclaim the refrigerant inside one Coil VEEs from this valves. There are about 5kg refrigerant inside One Coil VEEs. Make sure there is no positive pressure inside this Coil VEEs.

4, Remove flange cover from flange kit, note that possible residual positive pressure inside this One Coil VEEs result in safety issue, so firstly slightly loose the flange fasten bolt, make sure small gap between flange cover and flange RF seal surface to relieve residual positive pressure, and then remove flange cover from flange RF seal surface. Using stainless steel hose to connect two end flanges of main unit and auxiliary unit, and make sure good seal.

5, Do pressure testing, leak testing, strength testing for this section of refrigerant loop enclosed between four ball valves to make sure good seal and strength.

6, Do vacuum process in the pipe between 4 ball valves.

7, Open four ball valves used to isolated the main and auxiliary unit of Sys2.add refrigerant in sys2 per the refrigerant loss in the main and auxiliary unit connection process and the Sys2 actual running status.

8, Connection fan motor wiring terminal per schematic drawings. (Noted that schematic and fan wiring assembly should be accessory along with chiller shipment

9, Install 2 sets of back-to-back standing sheet metal and the 4 small pieces of sheet metal between the main and auxiliary unit according to Fig A.15-5 and Fig A.15-6 .Need to notice the fan desk between the main and auxiliary unit shall be fastened by bolts.

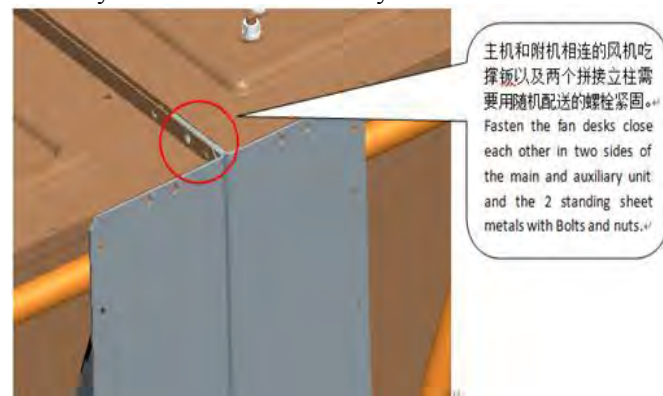

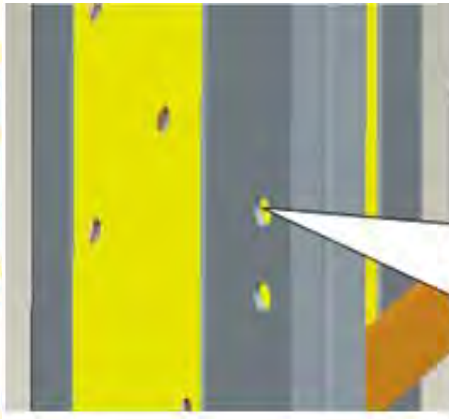
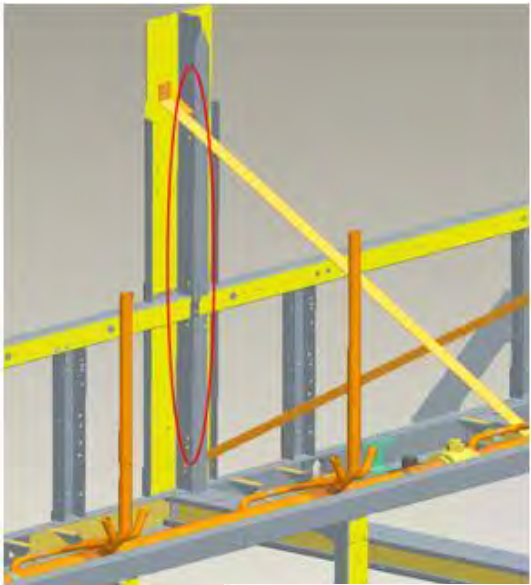

现场连接时，两个立柱上有多处孔需要安装 M12 螺栓紧固，共需约 20 组 M12 螺栓。
 Two sets of back-to-back standing sheet metal between the main and auxiliary unit need to be fastened with M12 bolts. And the overall amount of M12 bolt is about 20.

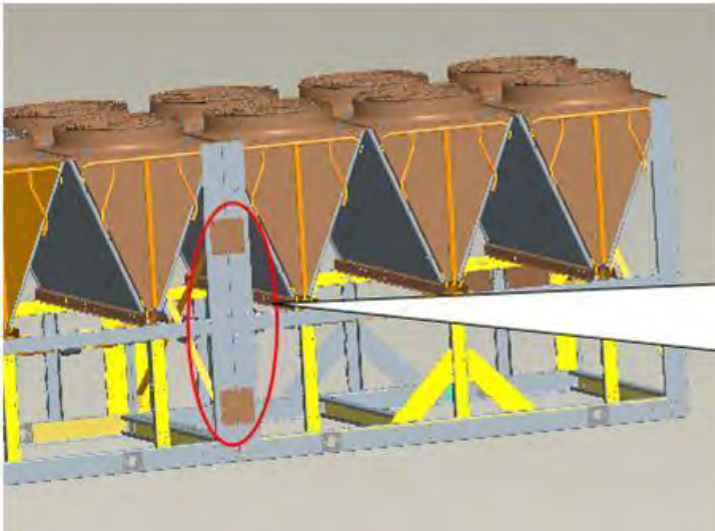

该板使用 M10 螺栓现场连接，约需 40 组。Need install 4 pieces of this sheet metal in two side of the unit with about 40 pieces of M10 bolts.

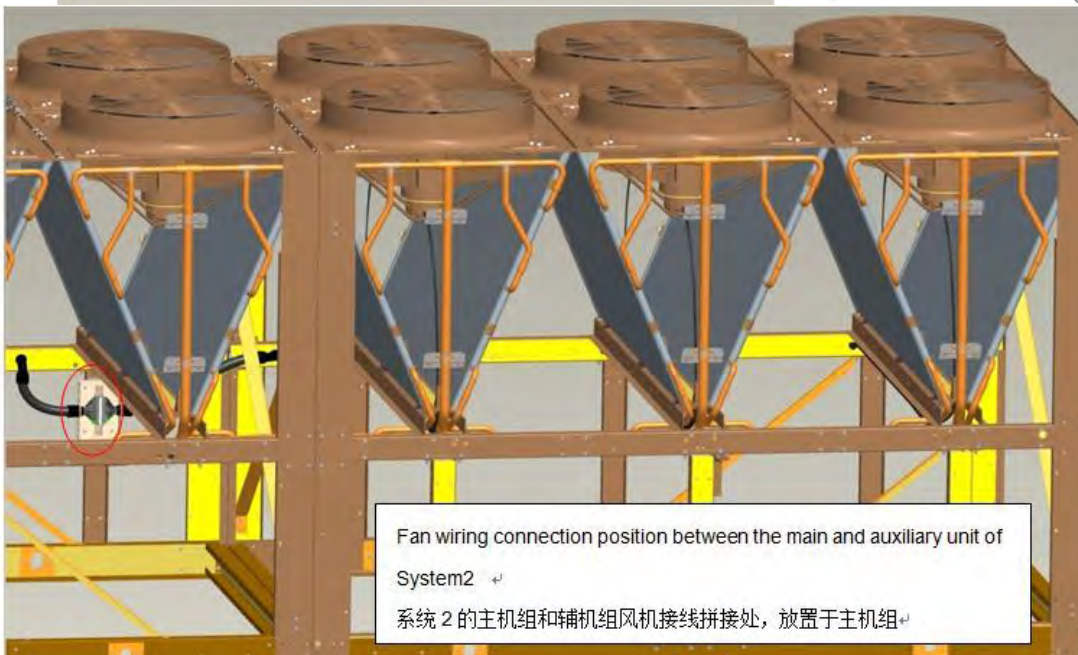

Fan wiring connection position between the main and auxiliary unit of System2
 系统 2 的主机组和辅机组风机接线拼接处，放置于主机组

FIGURE 5-YVAA MAIN AND AUXILIARY UNIT ASSEMBLY IN FIELD

THIS PAGE INTENTIONALLY LEFT BLANK

SECTION 4 - INSTALLATION

LOCATION REQUIREMENTS

For optimum performance and trouble-free service, it is essential that the installation site meet the location and space requirements for the model being installed.

It is important to ensure that the minimum service access space is maintained for cleaning and maintenance purposes.

OUTDOOR INSTALLATIONS

The units are designed for outdoor installation and can be installed at ground level on a suitable flat level foundation easily capable of supporting the weight of the unit, or on a suitable rooftop location. In both cases an adequate supply of air is required. Avoid locations where the sound output and air discharge from the unit may be objectionable.

The location should be selected for minimum sun exposure and away from boiler flues and other sources of airborne chemicals that could attack the condenser coils and steel parts of the unit.

If located in an area accessible to unauthorized persons, steps must be taken to prevent access to the unit by means of a protective fence. This will help to prevent the possibility of vandalism, accidental damage, or possible harm caused by unauthorized removal of protective guards or opening panels to expose rotating or high voltage components.

For ground level locations, the unit must be installed on a suitable flat and level concrete base that extends to fully support the two side channels of the unit base frame. A one-piece concrete slab, with footings extending below the frost line is recommended. To avoid noise and vibration transmission, the unit should not be secured to the building foundation.

On rooftop locations, choose a place with adequate structural strength to safely support the entire operating weight of the unit and service personnel. The unit can be mounted on a concrete slab, similar to ground floor locations, or on steel channels of suitable strength. The channels should be spaced with the same centers as the unit side and front base rails. This will allow vibration isolators to be fitted if required. Isolators are recommended for rooftop locations.

LOCATION CLEARANCES

Adequate clearances around the unit(s) are required for the unrestricted airflow for the air-cooled condenser coils and to prevent re-circulation of warm discharge air back onto the coils. If clearances given are not maintained, airflow restriction or re-circulation will cause a loss of unit performance, an increase in power consumption, and may cause the unit to malfunction. Consideration should also be given to the possibility of down drafts, caused by adjacent buildings, which may cause re-circulation or uneven unit airflow.

For locations where significant cross winds are expected, such as exposed roof tops, an enclosure of solid or louver type is recommended to prevent wind turbulence interfering with the unit airflow.

When units are installed in an enclosure, the enclosure height should not exceed the height of the unit on more than one side. If the enclosure is of louvered construction, the same requirement of static pressure loss applies as for ducts and attenuators stated above.

Recommended Minimum Clearances

Recommended clearances for the YVAA units are:

- Side to wall – 6' (1.8 m)
- Rear to wall – 6' (1.8 m)
- Control panel end to wall – 4' (1.2 m)
- Top – no obstructions whatsoever
- Distance between adjacent units – 10' (3 m)

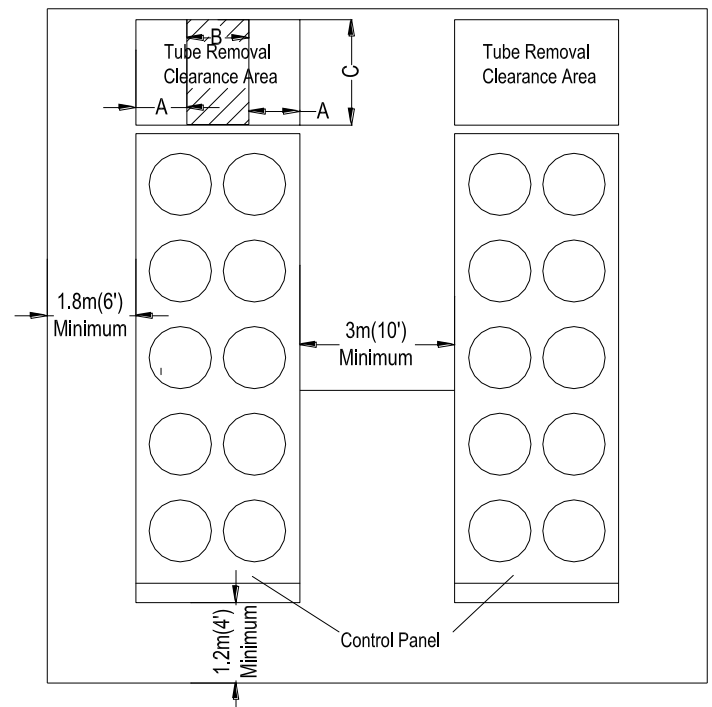

FIGURE 6-ACCEPTABLE MINIMUM CELARANCES AROUND/BETWEEN UNITS (S)

TABLE 1- MINIMUM EVAPORATOR TUBE

MODEL YVAA			TUBE REMOVAL					
			A		B		C	
FRAME	EVAP	COND	IN.	MM	IN.	MM	IN.	MM
015	3	B	26	663	36	914	132	3353
016	5	B	26	663	36	914	132	3353
017	8	C	26	663	36	914	156	3962
018	3	A	26	663	36	914	144	3658
019	5	A	26	663	36	914	144	3658
019	8	B	26	663	36	914	132	3353
020	0	C	26	663	36	914	156	3962
021	3	A	26	663	36	914	144	3658
021	5	C	26	663	36	914	156	3962
021	8	C	26	663	36	914	156	3962
023	3	B	26	663	36	914	132	3353
024	5	C	26	663	36	914	156	3962
024	8	C	26	663	36	914	156	3962
026	3	B	26	663	36	914	132	3353
027	3	D	26	663	36	914	192	4877
027	5	E	26	663	36	914	192	4877
027	8	E	26	663	36	914	192	4877
029	5	E	26	663	36	914	192	4877
030	3	C	26	663	36	914	156	3962
030	5	C	26	663	36	914	156	3962
030	8	E	26	663	36	914	192	4877
031	8	E	26	663	36	914	192	4877
032	3	E	26	663	36	914	192	4877
033	3	C	26	663	36	914	156	3962
034	3	E	26	663	36	914	192	4877
034	5	E	26	663	36	914	192	4877
037	3	F	26	663	36	914	192	4877
041	3	H	26	663	36	914	192	4877
044	3	G	26	663	36	914	192	4877
048	3	G	26	663	36	914	192	4877
052	3	J	26	663	36	914	192	4877



Clearance dimensions provided in Figure 5 are necessary to maintain good airflow and ensure correct unit operation. It is also necessary to consider access requirements for safe operation and maintenance of the unit and power and control panels. Local health and safety regulations, or practical considerations for service replacement of large components, may require larger clearances than those recommended.



The maximum flow rate and pressure drop for the cooler must not be exceeded at any time. Refer to SECTION 5 - TECHNICAL DATA on Page 37 for details.

The liquid must enter the cooler at the inlet connection. The inlet connection for the cooler is at the control panel end of the cooler.

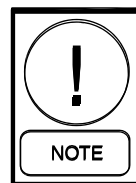

A flow switch must be installed in the customer piping at the outlet of the cooler and wired back to the control panel using shielded cable.

VIBRATION ISOLATORS

Optional sets of vibration isolators can be supplied loose with each unit.

Using the Isolator tables shipped with the unit in the information pack. Identify each mount and its correct location on the unit.

Installation

Place each mount in its correct position and lower the unit carefully onto the mounts ensuring the mount engages in the mounting holes in the unit base frame.

On adjustable mounts, transfer the unit weight evenly to the springs by turning the mount adjusting nuts (located just below the top plate of the mount) counterclockwise to raise and clockwise to lower. This should be done two turns at a time until the top plates of all mounts are between 1/4" (6 mm) and 1/2" (12 mm) clear of top of their housing and the unit base is level.

SHIPPING BRACES

The chiller's modular design does not require shipping braces.

CHILLED LIQUID PIPING GENERAL REQUIREMENTS

The following piping recommendations are intended to ensure satisfactory operation of the unit(s). Failure to follow these recommendations could cause damage to the unit, or loss of performance, and may invalidate the warranty.

There should be a straight run of piping of at least 5 pipe diameters on either side. The flow switch should be wired to Terminals 2 and 13 on the 1TB terminal block. A flow switch is required to prevent damage to the cooler caused by the unit operating without adequate liquid flow.

The flow switch used must have gold plated contacts for low voltage/current operation. Paddle type flow switches suitable for 10 bar (150 PSIG) working pressure and having a 1" N.P.T. connection can be obtained from Johnson Controls as an accessory for the unit. Alternatively, a differential pressure switch fitted across an orifice plate may be used, preferably of the high/low limit type.

The chilled liquid pump(s) installed in the piping system(s) should discharge directly into the unit cooler section of the system. The pump(s) may be controlled by the chiller controls or external to the unit.

Pipework and fittings must be separately supported to prevent any loading on the cooler. Flexible connections are recommended which will also minimize transmission of vibrations to the building. Flexible connections must be used if the unit is mounted on anti-vibration mounts, as some movement of the unit can be expected in normal operation.

Piping and fittings immediately next to the cooler should be readily de-mountable to enable cleaning before operation, and to facilitate visual inspection of the exchanger nozzles.

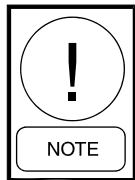

The cooler must be protected by a strainer, preferably of 40 mesh, fitted as close as possible to the liquid inlet connection, and provided with a means of local isolation.

The cooler must not be exposed to flushing velocities or debris released during flushing. It is recommended that a suitably sized bypass and valve arrangement is installed to allow flushing of the piping system. The bypass can be used during maintenance to isolate the heat exchanger without disrupting flow to other units.

Thermometer and pressure gauge connections should be provided on the inlet and outlet connections of each cooler. Gauges and thermometers are not provided with the unit and are to be furnished by others.

Drain and air vent connections should be provided at all low and high points in the piping to permit drainage of the system and to vent any air in the pipes.

Liquid system lines at risk of freezing, due to low ambient temperatures should be protected using insulation and heater tape and/or a suitable glycol solution. The liquid pump(s) may also be used to ensure liquid is circulated when the ambient temperature approaches freezing point.

Insulation should also be installed around the cooler nozzles. Heater tape of 21 Watts per meter under the insulation is recommended, supplied independently and controlled by an ambient temperature thermostat set to switch ON at approximately 2.2°C (4°F), above the freezing temperature of the chilled liquid.

The cooler is protected by heater mats placed under the insulation, which are powered from the unit control system power supply. During cold weather when there is a risk of freezing, chiller power should be left switched on to provide the freeze protection function unless the liquid systems have been drained.

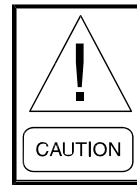

Any debris left in the water piping between the strainer and cooler could cause serious damage to the tubes in the cooler and must be avoided. Be sure the piping is clean before connecting it to the evaporator. Keep evaporator nozzles and chilled liquid piping capped prior to installation to assure construction debris is not allowed to enter.

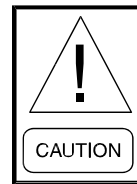

The installer/user must also ensure that the quality of the water in circulation is adequate, without any dissolved gases, which can cause oxidation of steel or copper parts within the cooler.

WATER TREATMENT

The unit performance provided in the Design Guide is based on a fouling factor of 0.018m²°C/kW (0.0001 ft²hr°F/Btu). Dirt, scale, grease and certain types of water treatment will adversely affect the heat exchanger surfaces and therefore the unit performance. Foreign matter in the water system(s) can increase the heat exchanger pressure drop, reducing the flow rate and causing potential damage to the heat exchanger tubes.

Aerated, brackish or salt water is not recommended for use in the water system(s). Johnson Controls recommends that a water treatment specialist should be consulted to determine whether the proposed water composition will adversely affect the evaporator materials of carbon steel and copper. The pH value of the water flowing through the evaporator must be kept in a range between 7 and 8.5.(see detail in Table 22.)

PIPEWORK ARRANGEMENT

The following is a suggested piping arrangement for single unit installations. For multiple unit installations, each unit should be piped as shown below.

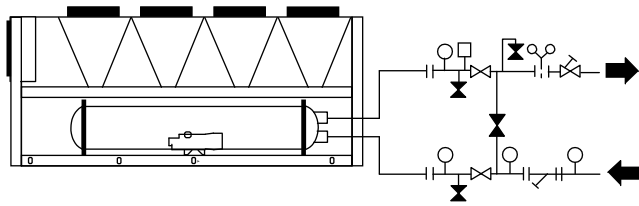

- Isolating Valve - Normally open
- Isolating Valve - Normally Closed
- Flow Regulating Valve
- Flow measurement Device
- Strainer
- Pressure Tapping
- Flow Switch
- Flanged Connection
- Pipework

LD15151

FIGURE 7- PIPEWORK ARRANGEMENT

MINIMUM WATER VOLUME

It is good practice to include as much water volume as possible in a chilled water loop. This increases the thermal mass and “Flywheel” effect within the system (i.e. the more; the better) which in turn promotes stable water temperature control and increases reliability by reducing compressor cycling.

For air conditioning applications, a minimum of 3 gallons/ton is required. It is preferred that the gallon/ton ratio be within the 5 to 8 range. For process applications, a minimum of 6 gallons/ton ratio is required with preference towards a range of 7 to 11. Install a tank or increase pipe sizes to provide sufficient water volume.

LEAVING WATER TEMPERATURE OUT OF RANGE

The YVAA chiller line has a maximum leaving water temperature of 15.6°C (60°F). Where process applications require a chilled water temperature higher than what the chiller provides, a simple piping change can remove the problem. By using a mixture of chiller-cooled water and returning process water, the chilled water entering the process can be held at the desired temperature. A tank can also be used to meet high leaving water temperature requirements.

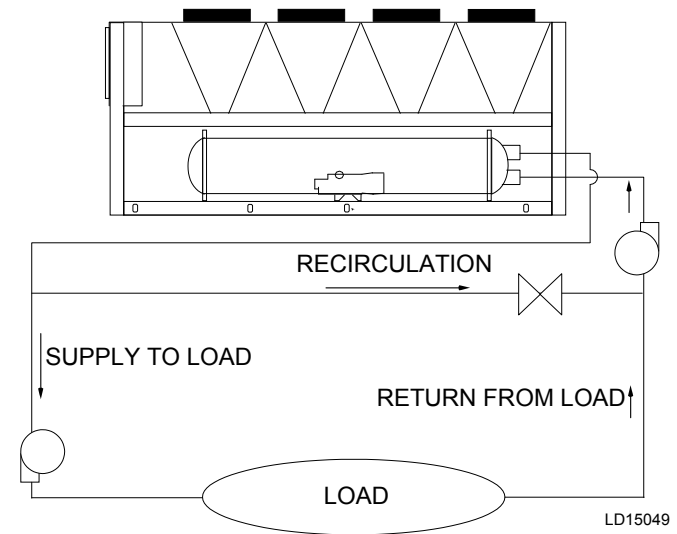

FIGURE 8- LEAVING WATER TEMPERATURE OUT

FLOW RATE OUT OF RANGE

Each YVAA evaporator has a minimum and maximum flow rate. Some process applications require a flow rate that is out of range for the evaporator. In those applications, a piping change can remove the problem.

In applications where the required flow rate is less than the evaporator’s minimum allowable, the chilled water can be recirculated to the chiller.

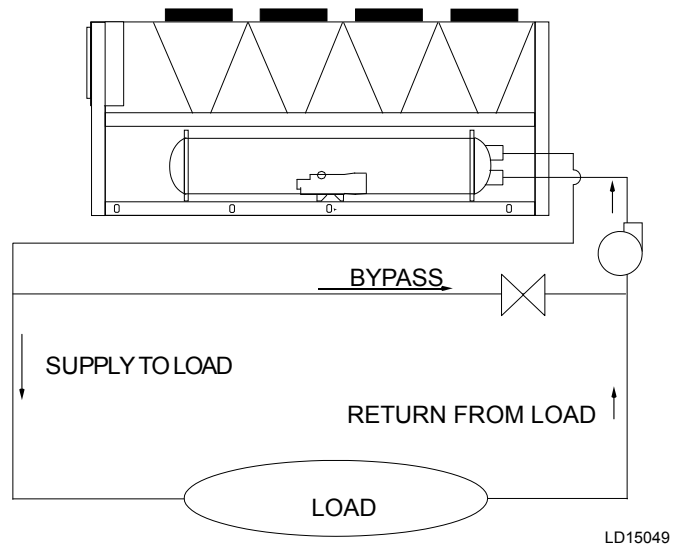

FIGURE 9- SUGGESTED LAYOUT FOR APPLICATIONS WITH A FLOW RATE LESS THAN THE EVAPORATOR MINIMUM ALLOWABLE FLOW RATE

In applications where the required flow rate is greater than the evaporator’s maximum allowable, the chilled water can be recirculated to the load.

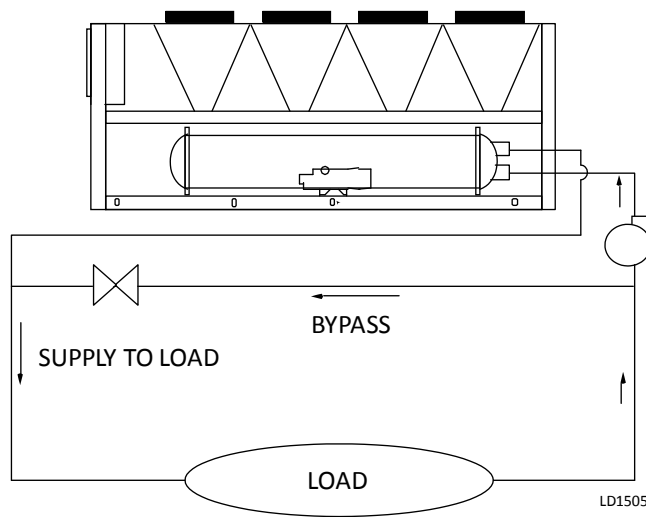

FIGURE 10- SUGGESTED LAYOUT FOR APPLICATIONS WITH A FLOW RATE GREATER THAN THE EVAPORATOR MAXIMUM ALLOWABLE FLOW RATE

THERMAL STORAGE

Thermal storage is the practice of storing cooling energy during a period of little or no load and/or low energy costs for use during periods of high load and/or energy costs. Conventional cooling systems produce cooling when it is needed which is commonly during times of peak demand. Thermal storage allows generation of cooling capacity to occur during off-peak periods and store that capacity to meet future cooling requirements. Using thermal storage can result in smaller equipment sizes, thereby reducing capital cost, and also can result in significant energy cost savings.

The YVAA has special control logic to be able to

produce chilled leaving brine temperatures below 4.4°C (40°F) so as to supply a storage tank with chilled liquid during times of low demand. YVAA chillers selected for thermal storage operation can also be selected to efficiently provide chilled fluid at nominal cooling loads.

VARIABLE PRIMARY FLOW

Johnson Controls recommends a maximum 10% per minute flow rate of change, based on design flow, for variable primary flow applications. Provide 8 to 10 gallons per chiller ton (8.6 to 10.8 liter per cooling KW) system water volume. Insufficient system volume and rapid flow changes can cause control problems or can even cause chiller shutdowns. There are many others design issues to evaluate with variable primary flow systems. Consult your Johnson Controls Sales Office for more information about successfully applying YVAA chillers

CONNECTION TYPES AND SIZES

For connection sizes relevant to individual models refer to *SECTION 5 - TECHNICAL DATA*.

COOLER CONNECTIONS

Standard chilled liquid connections on all coolers are of the Flange Type. Flanges standard shall conform to HG20625, and flange manufacture requirement refer to HG20615.

Optional chilled liquid connections on all coolers are of the Victaulic Groove type.

Users need to connect water system to the cooler with appropriate flanges to match that of coolers as following Table 2.

TABLE 2 - COOLER FLANGE DIMENSIONS

Nominal Diameter		Dimension /mm							Quantity
		B	C	D	K	L	d	n	
4"	DN100	116	24	230	190.5	18	157.5	8	2
5"	DN125	141.5	26	255	216	22	186	8	2
6"	DN150	170.5	27	280	241.5	22	216	8	2
8"	DN200	221.5	27	345	298.5	22	270	8	2
10"	DN250	276.5	41	405	362	26	324	12	2

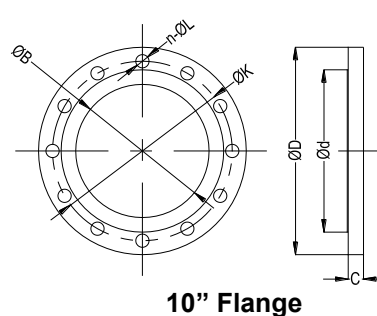
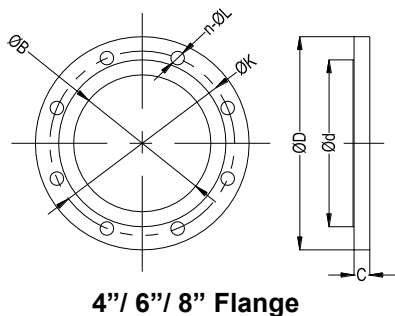

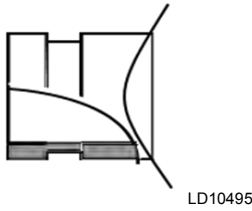

FIGURE 12– VICTAULIC GROOVE

REFRIGERANT RELIEF VALVE PIPING

The evaporator is protected against internal refrigerant overpressure by refrigerant relief valves. A pressure relief valve is mounted on each of the main refrigerant lines connecting the cooler to the compressors

A piece of pipe is fitted to each valve and directed so that when the valve is activated the release of high pressure gas and liquid cannot be a danger or cause injury. For indoor installations (not recommended), pressure relief valves should be piped to the exterior of the building.

The size of any piping attached to a relief valve must be of sufficient diameter so as not to cause resistance to the operation of the valve. Unless otherwise specified by local regulations. Internal diameter depends on the length of pipe required and is given by the following formula:

$$D^5 = 1.447 \times L$$

- Where:
- D = minimum pipe internal diameter in cm
- L = length of pipe in meters

If relief piping is common to more than one valve, its cross-sectional area must be at least the total required by each valve. Valve types should not be mixed on a common pipe. Precautions should be taken to ensure the outlets of relief valves or relief valve vent pipes remain clear of obstructions at all times.

ELECTRICAL CONNECTION

The following connection recommendations are intended to ensure safe and satisfactory operation of the unit. Failure to follow these recommendations could cause harm to persons or damage the unit, and may invalidate the warranty.



No additional controls (relays, etc.) should be mounted in the control panel. Power and control wiring not connected to the control panel should not be run through the control panel. If these precautions are not followed it could lead

to a risk of electrocution. In addition, electrical noise could cause malfunctions or damage the unit and its controls.



After power wiring connection, do not switch on mains power to the unit. Some internal components are live when the mains are switched on and this must only be done by “Authorized” persons familiar with starting, operating, and troubleshooting this type of equipment.

POWER WIRING

All electrical wiring should be carried out in accordance with local regulations. Route properly sized cables to cable entries on the unit.

In accordance with local codes, NEC codes, U.L. and C.E. standards, it is the responsibility of the user to install over current protection devices between the supply conductors and the power supply terminals on the unit.

To ensure that no eddy currents are set up in the power panel, the cables forming the 3-phase power supply must enter via the same cable entry.

All customer wiring at the jobsite must be routed to avoid high temperature areas (compressor shells, discharge piping, ambient coils and other hot surfaces) and sharp edges on the unit, to prevent damage to the wiring and possible short circuits. If these precautions are not followed it could lead to a risk of electrocution or damage to the unit and its controls.



All sources of supply to the unit must be taken via a common point of isolation (not supplied by Johnson Controls).

POWER SUPPLY WIRING

Units require only one 3-phase supply, plus earth.

Connect the 3-phase supplies to the circuit breaker located in the panel (See Electrical Lug Data in *Table 2 on Page 32 and Table 3 on Page 34*).

Connect a suitably sized earth wire to the PE terminal in the panel.

115VAC CONTROL SUPPLY TRANSFORMER

A 3-wire high voltage to 115VAC supply transformer is standard in the chiller. This transformer is mounted in the cabinet and steps down the high voltage supply to 115VAC to be used by the controls, VSD, Feed and Drain Valve Controller, valves, solenoids, heaters, etc. The high voltage for the transformer primary is taken from the chiller input. Fusing is provided for the transformer.



Removing high voltage power to the chiller will remove the 115VAC supply voltage to the control panel circuitry and the evaporator heater. In cold weather, this could cause serious damage to the chiller due to evaporator freeze-up. Do not remove power unless alternate means are taken to ensure operation of the evaporator heater.

CONTROL WIRING

All control wiring utilizing contact closures to the control panel terminal block is nominal 115VAC and must be run in shielded cable, with the shield grounded at the panel end only, and run in water tight conduit. Run shielded cable separately from mains cable to avoid electrical noise pick-up. Use the control panel cable entry to avoid the power cables.

Voltage free contacts connected to the panel must be suitable for 115VAC10 ma (gold contacts recommended). If the voltage free contacts form part of a relay or contactor, the coil of the device must be suppressed using a standard R/C suppressor. The above precautions must be taken to avoid electrical noise, which could cause a malfunction or damage to the unit and its controls.

VOLTS FREE CONTACTS

Chilled Liquid Pump Starter

Terminals 23 and 24 on 1TB close to start the chilled liquid pump. This contact can be used as a master start/stop for the pump in conjunction with the daily start/stop schedule.

Run Contact

Terminals 21 and 22 on 1TB close to indicate that a system is running.

Alarm Contacts

Each system has a single voltage-free contact, which will operate to signal an alarm condition whenever any

system locks out, or there is a power failure. To obtain system alarm signal, connect the alarm circuit to volt free Terminals 25 & 26 (Sys 1), Terminals 27 and 28 (Sys 2) of 1TB.

SYSTEM INPUTS

Flow Switch

A chilled liquid flow switch of suitable type MUST be connected between Terminals 2 and 13 of 1TB to provide protection against loss of liquid flow, which will cause evaporator freeze-up if the chiller is permitted to run. The flow switch circuitry is a 115VAC circuit. Contacts must be rated for low current (5mA). Gold contacts should be used.

Remote Run / Stop

A Remote Run/Stop input is available for each system. These inputs require a dry contact to start and stop the system. System 1 remote dry contacts are connected between Terminals 2 and 15 of 1TB and System 2 dry contacts are connected between Terminals 2 and 16 of 1TB. If remote start/stop is not utilized, a jumper must be placed across the terminals to allow the system to run. The remote run/stop circuitry is a 115VAC circuit. Contacts must be rated for low current (5mA). Gold contacts should be used.

Remote Print

Closure of suitable contacts connected to Terminals 2 and 14 of 1TB will cause a hard copy printout of Operating Data/Fault History to be made if an optional printer is connected to the RS-232 port. The remote print circuitry is a 115VAC circuit. Contacts must be rated for low current (5mA). Gold contacts should be used.

Optional Remote Setpoint Offset – Temperature

A voltage signal connected to Terminals 17 and 18 of 1TB will provide a remote offset function of the chilled liquid setpoint, if required.

Optional Remote Setpoint Offset – Current

A voltage signal connected to Terminals 19 and 20 of 1TB will provide a remote setting of current limit setpoint, if required.

Optional Remote Setpoint Offset – Sound Limiting

A voltage signal connected to Terminals 40 and 41 of 1TB will provide remote setting of sound limit setpoint, if required.

POWER SUPPLY WIRING

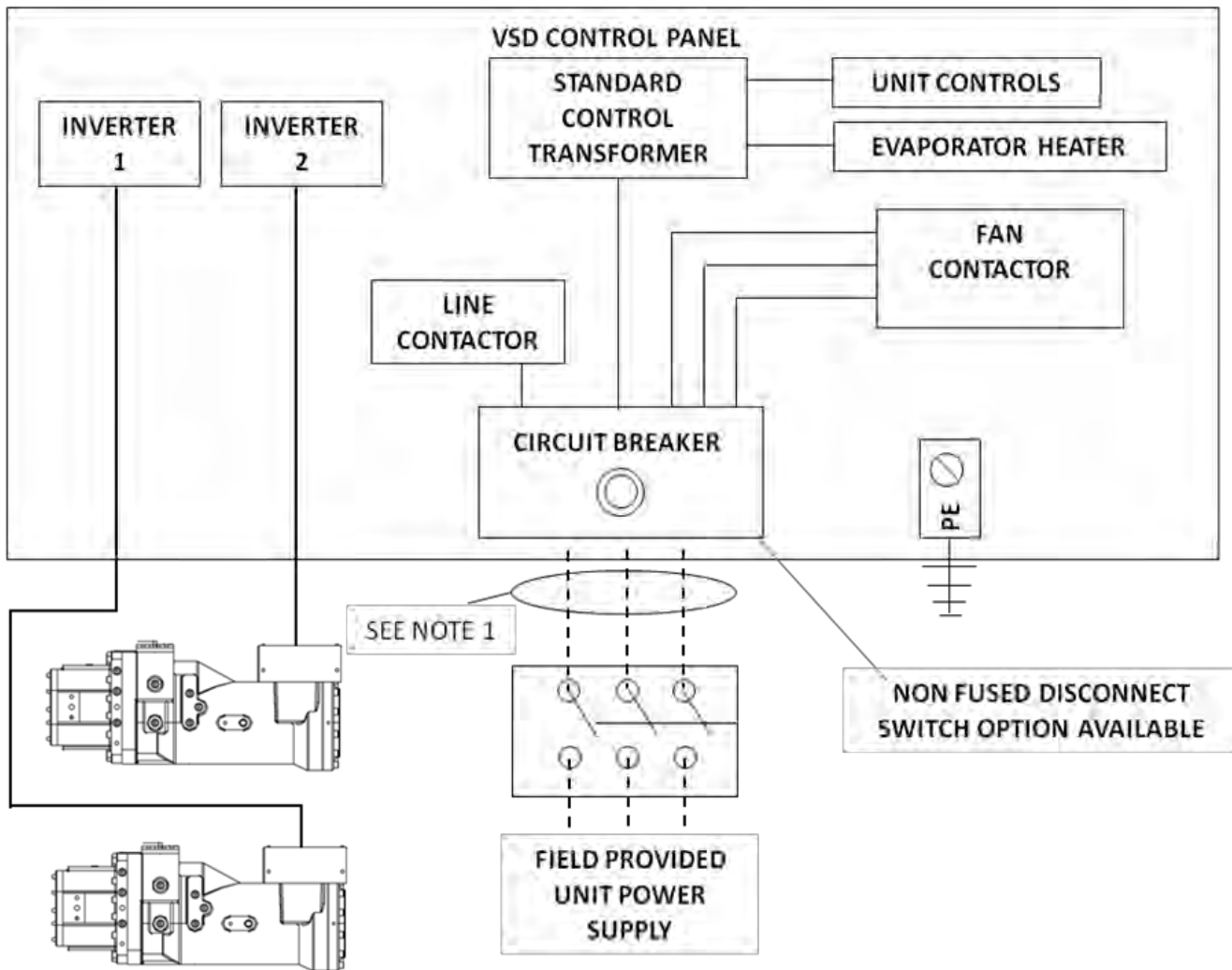

NOTES:

- 1. ----- Dashed Line = Field Provided Wiring
- 2. The transformer is located in a separate box that is attached to the bottom of the control panel.

FIGURE 13- POWER CONNECTIONS

CUSTOMER CONTROL WIRING

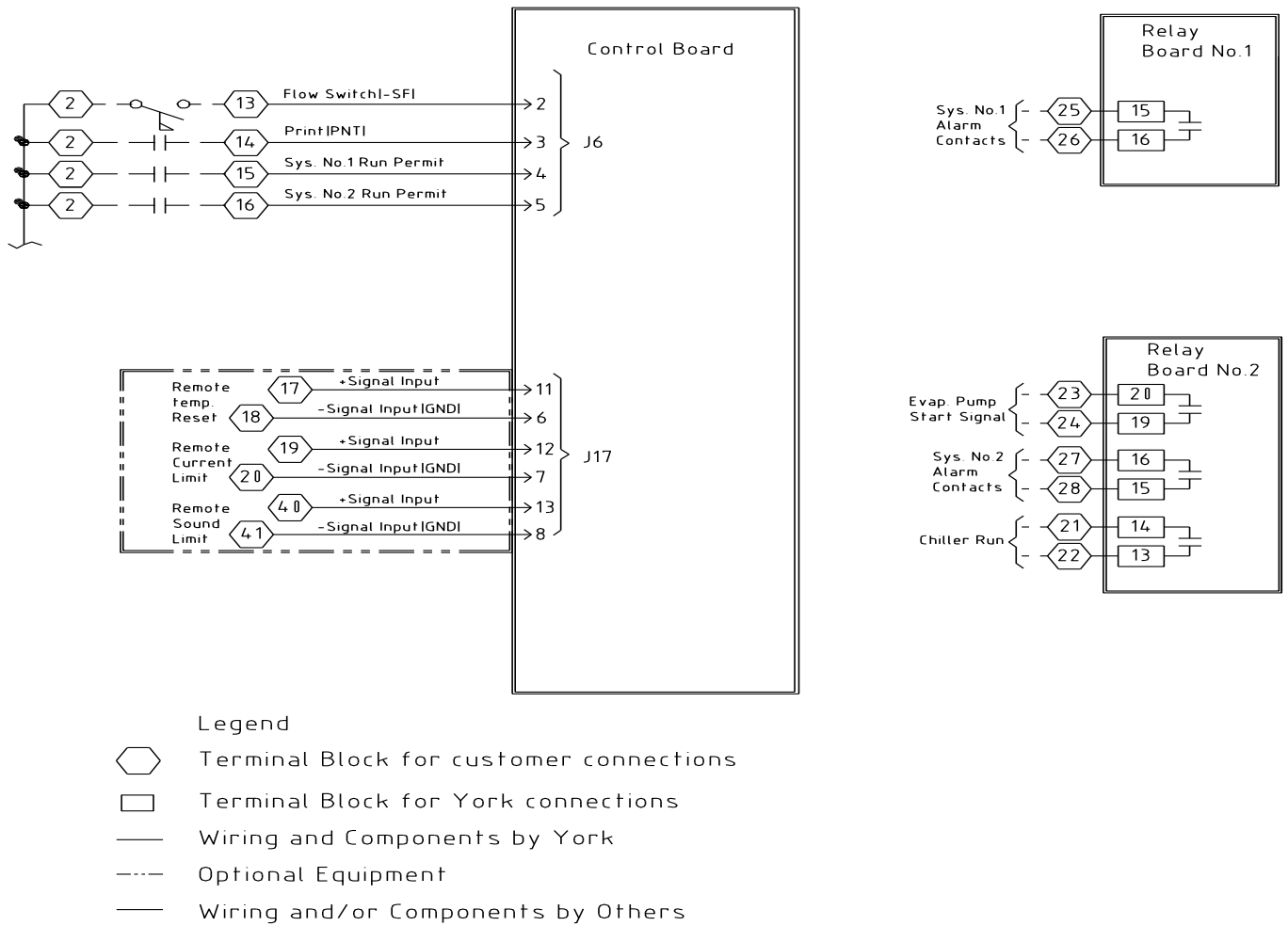

FIGURE 14- CUSTOMER CONTROL CONNECTIONS



TABLE 3 - ELECTRICAL DATA - STANDARD AND ULTRA QUIET CONDENSER FANS

FIELD WIRING LUGS			TERMINAL BLOCK			CIRCUIT BREAKER		NON-FUSED DISCONNECT SWITCH		
YVAA MODEL			INPUT VOLT S	INPUT FREQUENCY	LUGS PER PHASE	LUG WIRE RANGE	LUGS PER PHASE	LUG WIRE RANGE	LUGS PER PHASE	LUG WIRE RANGE
FRAME	CONDENSER	EVAPORATOR				Kcmil		Kcmil		Kcmil
15	3	B	400	50	2	#2 - 600kcmil	2	#2/0 ~ 500 kcmil	2	#2 - 600kcmil
16	5	B	400	50	2	#2 - 600kcmil	2	#2/0 ~ 500 kcmil	2	#2 - 600kcmil
17	8	C	400	50	2	#2 - 600kcmil	2	#2/0 ~ 500 kcmil	2	#2 - 600kcmil
18	3	A	400	50	2	#2 - 600kcmil	2	#1 ~ 500 kcmil	3	#2 - 600kcmil
19	5	A	400	50	2	#2 - 600kcmil	2	#1 ~ 500 kcmil	3	#2 - 600kcmil
19	8	B	400	50	2	#2 - 600kcmil	2	#1 ~ 500 kcmil	3	#2 - 600kcmil
20	0	C	400	50	3	#2 - 600kcmil	3	3/0 ~ 400 kcmil	3	#2 - 600kcmil
21	3	A	400	50	2	#2 - 600kcmil	2	#1 ~ 500 kcmil	3	#2 - 600kcmil
21	5	C	400	50	2	#2 - 600kcmil	2	#1 ~ 500 kcmil	3	#2 - 600kcmil
21	8	C	400	50	2	#2 - 600kcmil	2	#1 ~ 500 kcmil	3	#2 - 600kcmil
23	3	B	400	50	3	#2 - 600kcmil	3	3/0 ~ 400 kcmil	3	#2 - 600kcmil
24	5	C	400	50	3	#2 - 600kcmil	3	3/0 ~ 400 kcmil	3	#2 - 600kcmil
24	8	C	400	50	3	#2 - 600kcmil	3	3/0 ~ 400 kcmil	3	#2 - 600kcmil
26	3	B	400	50	3	#2 - 600kcmil	3	3/0 ~ 400 kcmil	3	#2 - 600kcmil
27	3	D	400	50	3	#2 - 600kcmil	3	3/0 ~ 400 kcmil	3	#2 - 600kcmil
27	5	E	400	50	3	#2 - 600kcmil	3	3/0 ~ 400 kcmil	3	#2 - 600kcmil
27	8	E	400	50	3	#2 - 600kcmil	3	3/0 ~ 400 kcmil	3	#2 - 600kcmil
29	5	E	400	50	3	#2 - 600kcmil	4	#4/0 ~ 500 kcmil	3	#2 - 600kcmil
30	3	C	400	50	3	#2 - 600kcmil	4	#4/0 ~ 500 kcmil	3	#2 - 600kcmil
30	5	C	400	50	3	#2 - 600kcmil	4	#4/0 ~ 500 kcmil	3	#2 - 600kcmil
30	8	E	400	50	3	#2 - 600kcmil	4	#4/0 ~ 500 kcmil	3	#2 - 600kcmil
31	8	E	400	50	3	#2 - 600kcmil	4	#4/0 ~ 500 kcmil	3	#2 - 600kcmil
32	3	E	400	50	3	#2 - 600kcmil	4	#4/0 ~ 500 kcmil	3	#2 - 600kcmil
33	3	C	400	50	3	#2 - 600kcmil	4	#4/0 ~ 500 kcmil	3	#2 - 600kcmil
34	3	E	400	50	3	#2 - 600kcmil	4	#4/0 ~ 500 kcmil	3	#2 - 600kcmil
34	5	E	400	50	3	#2 - 600kcmil	4	#4/0 ~ 500 kcmil	3	#2 - 600kcmil
37	3	F	400	50	3	#2 - 600 kcmil	3	#3/0 ~ 400 kcmil	3	#3/0 ~ 400 kcmil
41	3	H	400	50	3	#2 - 600 kcmil	3	#3/0 ~ 400 kcmil	3	#3/0 ~ 400 kcmil
44	3	G	400	50	3	#2 - 600 kcmil	3	#3 /0~ 400 kcmil	3	#3/0 ~ 400 kcmil
48	3	G	400	50	3	#2 - 600 kcmil	3	#3 /0~ 400 kcmil	3	#3/0 ~ 400 kcmil
52	3	J	400	50	3	#2 - 600 kcmil	3	#3 /0~ 500 kcmil	3	#3 /0~ 500 kcmil

TABLE 4- ELECTRICAL DATA - HIGH AIRFLOW/HIGH STATIC CONDENSER FANS

FIELD WIRING LUGS					TERMINAL BLOCK		CIRCUIT BREAKER		NON-FUSED DISCONNECT SWITCH	
YVAA MODEL			INPUT VOLTS	INPUT FREQUENCY	LUGS PER PHASE	LUG WIRE RANGE	LUGS PER PHASE	LUG WIRE RANGE	LUGS PER PHASE	LUG WIRE RANGE
FRAME	CONDENSER	EVAPORATOR				Kcmil		Kcmil		Kcmil
15	3	B	400	50	2	#2 - 600kcmil	2	#1 ~ 500 kcmil	3	#2 - 600kcmil
16	5	B	400	50	2	#2 - 600kcmil	2	#1 ~ 500 kcmil	3	#2 - 600kcmil
17	8	C	400	50	2	#2 - 600kcmil	2	#1 ~ 500 kcmil	3	#2 - 600kcmil
18	3	A	400	50	3	#2 - 600kcmil	3	3/0 ~ 400 kcmil	3	#2 - 600kcmil
19	5	A	400	50	3	#2 - 600kcmil	3	3/0 ~ 400 kcmil	3	#2 - 600kcmil
19	8	B	400	50	3	#2 - 600kcmil	3	3/0 ~ 400 kcmil	3	#2 - 600kcmil
20	0	C	400	50	3	#2 - 600kcmil	3	3/0 ~ 400 kcmil	3	#2 - 600kcmil
21	3	A	400	50	3	#2 - 600kcmil	3	3/0 ~ 400 kcmil	3	#2 - 600kcmil
21	5	C	400	50	3	#2 - 600kcmil	3	3/0 ~ 400 kcmil	3	#2 - 600kcmil
21	8	C	400	50	3	#2 - 600kcmil	3	3/0 ~ 400 kcmil	3	#2 - 600kcmil
23	3	B	400	50	3	#2 - 600kcmil	3	3/0 ~ 400 kcmil	3	#2 - 600kcmil
24	5	C	400	50	3	#2 - 600kcmil	3	3/0 ~ 400 kcmil	3	#2 - 600kcmil
24	8	C	400	50	3	#2 - 600kcmil	3	3/0 ~ 400 kcmil	3	#2 - 600kcmil
26	3	B	400	50	3	#2 - 600kcmil	3	3/0 ~ 400 kcmil	3	#2 - 600kcmil
27	3	D	400	50	3	#2 - 600kcmil	3	3/0 ~ 400 kcmil	3	#2 - 600kcmil
27	5	E	400	50	3	#2 - 600kcmil	3	3/0 ~ 400 kcmil	3	#2 - 600kcmil
27	8	E	400	50	3	#2 - 600kcmil	3	3/0 ~ 400 kcmil	3	#2 - 600kcmil
29	5	E	400	50	4	#2 - 600kcmil	4	#4/0 ~ 500 kcmil	4	#2 - 600kcmil
30	3	C	400	50	4	#2 - 600kcmil	4	#4/0 ~ 500 kcmil	4	#2 - 600kcmil
30	5	C	400	50	4	#2 - 600kcmil	4	#4/0 ~ 500 kcmil	4	#2 - 600kcmil
30	8	E	400	50	4	#2 - 600kcmil	4	#4/0 ~ 500 kcmil	4	#2 - 600kcmil
31	8	E	400	50	4	#2 - 600kcmil	4	#4/0 ~ 500 kcmil	4	#2 - 600kcmil
32	3	E	400	50	4	#2 - 600kcmil	4	#4/0 ~ 500 kcmil	4	#2 - 600kcmil
33	3	C	400	50	4	#2 - 600kcmil	4	#4/0 ~ 500 kcmil	4	#2 - 600kcmil
34	3	E	400	50	4	#2 - 600kcmil	4	#4/0 ~ 500 kcmil	4	#2 - 600kcmil
34	5	E	400	50	4	#2 - 600kcmil	4	#4/0 ~ 500 kcmil	4	#2 - 600kcmil
37	3	F	400	50	3	#2 - 600 kcmil	3	#3/0 ~ 400 kcmil	3	#3/0 ~ 400 kcmil
41	3	H	400	50	3	#2 - 600 kcmil	3	#3/0 ~ 400 kcmil	3	#3 /0~ 400 kcmil
44	3	G	400	50	3	#2 - 600 kcmil	3	#3/0 ~ 400 kcmil	3	#3 /0~ 400 kcmil
48	3	G	400	50	3	#2 - 600 kcmil	3	#3/0 ~ 400 kcmil	3	#3/0~ 400 kcmil
52	0	J	400	50	3	#2 - 600 kcmil	3	#3 /0~ 400 kcmil	3	#3 /0~ 400 kcmil

SECTION 5 - TECHNICAL DATA

NOMENCLATURE

YVAA 015 XXXX 50 AA

1 2 3 4
BASE PRODUCT TYPE

Y : York
V : Variable Speed Screw
A : Air cooled
A

5 6 7
FRAME SIZE

#

8 9 10 11
CONFIGURATION

: Condenser code
: Evaporator code
: Compressor code
: Condenser fan & sound kit code

12 13
VOLTAGE

1	7	: 200 / 3 / 60
2	8	: 230 / 3 / 60
4	0	: 380 / 3 / 60
4	6	: 460 / 3 / 60
5	0	: 380-415 / 3 / 50
5	8	: 575 / 3 / 60

14 15
LEVEL / REFRIGERANT

A : Development Level A
A : Refrigerant R134a



Products are produced at a facility whose quality-management systems are ISO9001 certified.



ASHRAE 90.1 Compliant



TABLE 5- PHYSICAL DATA (ENGLISH)

The data shown in this table is applicable to selected typical configurations. Other configurations are available through our configuration/selection software. Please contact your nearest Johnson Controls Sales Office for the chiller configuration that best matches your specific needs.

UNIT FRAME	015	016	017	018	019	019	020	021	021	021	023	024	024
CONDENSER CODE	3	5	8	3	5	8	0	3	5	8	3	5	8
EVAPORATOR CODE	B	B	C	A	A	B	C	A	C	C	B	C	C
GENERAL UNIT DATA													
Number of Independent Refrigerant Circuits	2												
Refrigerant Charge, R-134a, Circuit -1, lbs	175	190	225	175	190	220	205	175	225	240	210	250	250
Refrigerant Charge, R-134a, Circuit -2, lbs	175	190	225	155	170	195	205	175	225	240	190	225	250
Oil Charge, Circuit -1, gal	2	2.2	2.5	2.4	2.6	2.7	2.6	2.5	2.8	2.9	2.7	2.9	2.9
Oil Charge, Circuit -2, gal	2	2.2	2.5	2	2.1	2.2	2.6	2.5	2.8	2.9	2.6	2.8	2.9
% minimum Load	10%												
Unit shipping weight, lbs ¹	11518	12084	14668	12019	12781	13776	13392	12859	14915	15677	13288	15873	16634
Operating Weight, lbs ¹	11979	12546	15432	12460	13222	14237	14155	13300	15678	16440	13750	16636	17398
Chassis Dimensions - Length, inches	203.3	247.2	291.2	247.2	291.2	335.2	226	291.2	291.2	335.2	291.2	335.2	379.2
Chassis Dimensions - Width, inches	88.3	88.3	88.3	88.3	88.3	88.3	88.3	88.3	88.3	88.3	88.3	88.3	88.3
Chassis Dimensions - Height, inches	94.6	94.6	94.6	94.6	94.6	94.6	94.6	94.6	94.6	94.6	94.6	94.6	94.6
COMPRESSORS, SEMI-HERMETIC SCREW													
Quantity per Chiller	2												
CONDENSER FANS													
Number Ckt-1/Ckt-2	4/4	5/5	6/6	6/4	7/5	8/6	4/4	6/6	6/6	7/7	7/5	8/6	8/8
EVAPORATOR, TUBE IN SHELL HYBRID FALLING FILM 2													
Water Volume, gal	58	58	71	48	48	58	71	48	71	71	58	71	71
Leaving Water Temperature (Min/Max), °F ³	40/60												
Air on Condenser (Min/Max), °F	0/125												
Maximum Water Side Pressure, psig	150												
Optional 300 psi Maximum Water Side Pressure, psig	300												
Maximum refrigerant Side Pressure, psig	235												
Evaporator Drain Connection, in	3/4"												
Minimum Chilled Water Flow rate- standard two pass, gpm	250	250	300	200	200	250	300	200	300	300	250	300	300
Maximum Chilled Water Flow rate- standard two pass, gpm	950	950	1150	750	750	950	1150	750	1150	1150	950	1150	1150
Minimum Chilled Water Flow rate- optional one pass, gpm	501	501	599	399	399	501	599	399	599	599	501	599	599
Maximum Chilled Water Flow rate- optional one pass, gpm	1899	1899	2301	1499	1499	1899	2301	1499	2301	2301	1899	2301	2301
Minimum Chilled Water Flow rate- optional three pass, gpm	160	160	200	120	120	160	200	120	200	200	160	200	200
Maximum Chilled Water Flow rate- optional three pass, gpm	600	600	750	500	500	600	750	500	750	750	600	750	750
Inlet and outlet Water Connections- standard two pass, in	6	6	6	6	6	6	6	6	6	6	6	6	6
Inlet and outlet Water Connections- optional one pass, in	8	8	8	6	6	8	8	6	8	8	8	8	8
Inlet and outlet Water Connections- optional three pass, in	5	5	6	5	5	5	6	5	6	6	5	6	6

NOTES:

- Shipping and operating weights shown are for base unit; selected options may add weight to unit. Contact your nearest Johnson Controls Sales office for weight data.
- The evaporator is protected against freezing to 0°F (-17.8°C) with a standard heater.
- For leaving liquid temperature below 40°F (4.4°C) or above 60°F (15.6°C), contact your nearest Johnson Controls Sales Office for application requirements.

TABLE 5 - PHYSICAL DATA (ENGLISH) (CONT'D)

The data shown in this table is applicable to selected typical configurations. Other configurations are available through our configuration/selection software. Please contact your nearest Johnson Controls Sales Office for the chiller configuration that best matches your specific needs.

UNIT FRAME	026	027	027	027	029	030	030	030	031	032	033	034	034
CONDENSER CODE	3	3	5	8	5	3	5	8	8	3	3	3	5
EVAPORATOR CODE	B	D	E	E	E	C	C	E	E	E	C	E	E
GENERAL UNIT DATA													
Number of Independent Refrigerant Circuits	2												
Refrigerant Charge, R-134a, Circuit - 1, lbs	210	265	265	270	310	290	295	315	315	295	290	310	315
Refrigerant Charge, R-134a, Circuit - 2, lbs	210	265	265	270	265	245	250	275	295	295	290	310	315
Oil Charge, Circuit -1, gal	2.7	3	3	3.1	4.2	4.1	4.1	4.3	4.3	4.1	4.1	4.2	4.3
Oil Charge, Circuit -2, gal	2.7	3	3	3.1	3.1	3	3	3.2	3.3	4.1	4.1	4.2	4.3
% minimum Load	10%												
Unit shipping weight, lbs ¹	14706	16275	16991	17753	18205	17114	18967	18967	19728	18554	18224	19315	20077
Operating Weight, lbs ¹	14538	17103	17851	18612	19065	17877	19827	19827	20588	19414	18987	20175	20937
Chassis Dimensions - Length, inches	335.2	335.2	335.2	379.2	379.2	379.2	423.1	423.1	467.1	379.2	423.1	423.1	467.1
Chassis Dimensions - Width, inches	88.3	88.3	88.3	88.3	88.3	88.3	88.3	88.3	88.3	88.3	88.3	88.3	88.3
Chassis Dimensions - Height, inches	94.6	94.6	94.6	94.6	94.6	94.6	94.6	94.6	94.6	94.6	94.6	94.6	94.6
COMPRESSORS, SEMI-HERMETIC SCREW													
Quantity per Chiller	2												
CONDENSER FANS													
Number Ckt-1/Ckt-2	7/7	7/7	7/7	8/8	9/7	9/7	10/8	10/8	10/10	8/8	9/9	9/9	10/10
EVAPORATOR, TUBE IN SHELL HYBRID FALLING FILM ²													
Water Volume, gal	58	82	113	113	113	71	71	113	113	113	71	113	113
Leaving Water Temperature (Min/Max), °F ³	40/60												
Air on Condenser (Min/Max), °F	0/125												
Maximum Water Side Pressure, psig	150												
Optional 300 psi Maximum Water Side Pressure, psig	300												
Maximum refrigerant Side Pressure, psig	235												
Evaporator Drain Connection, in	3/4"												
Minimum Chilled Water Flow rate-standard two pass, gpm	250	300	400	400	400	300	300	400	400	400	300	400	400
Maximum Chilled Water Flow rate-standard two pass, gpm	950	1150	1500	1500	1500	1150	1150	1500	1500	1500	1150	1500	1500
Minimum Chilled Water Flow rate-optional one pass, gpm	501	599	799	799	799	599	599	799	799	799	599	799	799
Maximum Chilled Water Flow rate-optional one pass, gpm	1899	2301	3002	3002	3002	2301	2301	3002	3002	3002	2301	3002	3002
Minimum Chilled Water Flow rate-optional three pass, gpm	160	200	300	300	300	200	200	300	300	300	200	300	300
Maximum Chilled Water Flow rate-optional three pass, gpm	600	750	850	850	850	750	750	850	850	850	750	850	850
Inlet and outlet Water Connections-standard two pass, in	6	6	8	8	8	6	6	8	8	8	6	8	8
Inlet and outlet Water Connections-optional one pass, in	8	8	10	10	10	8	8	10	10	10	8	10	10
Inlet and outlet Water Connections-optional three pass, in	5	6	6	6	6	6	6	6	6	6	6	6	6

NOTES:

- Shipping and operating weights shown are for base unit; selected options may add weight to unit. Contact your nearest Johnson Controls Sales office for weight data.
- The evaporator is protected against freezing to 0°F (-17.8°C) with a standard heater.
- For leaving liquid temperature below 40°F (4.4°C) or above 60°F (15.6°C), contact your nearest Johnson Controls Sales Office for application requirements.

TABLE 5 - PHYSICAL DATA (ENGLISH) (CONT'D)

The data shown in this table is applicable to selected typical configurations. Other configurations are available through our configuration/selection software. Please contact your nearest Johnson Controls Sales Office for the chiller configuration that best matches your specific needs.

UNIT FRAME	037	041	044	048	052
CONDENSER CODE	3	3	3	3	3
EVAPORATOR CODE	F	H	G	G	J
GENERAL UNIT DATA					
Number of Independent Refrigerant Circuits	2				
Refrigerant Charge, R-134a, Circuit -1, lbs	420	460	370	385	445
Refrigerant Charge, R-134a, Circuit -2, lbs	245	345	370	385	445
Oil Charge, Circuit -1, gal	5.3	5.5	5	5.1	5.4
Oil Charge, Circuit -2, gal	2.9	4.3	5	5.1	5.4
% minimum Load	10%				
Unit shipping weight, lbs ¹	22346	21241	25941	26704	22346
Operating Weight, lbs ¹	23404	22048	27000	27762	29762
Chassis Dimensions - Length, inches	467.12	467.12	467.12 / 88.18	467.12 / 132.16	467.12 / 132.16
Chassis Dimensions - Width, inches	88.51	88.51	88.51	88.51	88.51
Chassis Dimensions - Height, inches	94.77	94.77	94.77	94.77	94.77
COMPRESSORS, SEMI-HERMETIC SCREW					
Quantity per Chiller	2				
CONDENSER FANS					
Number Ckt-1/Ckt-2	13/7	12/8	12/12	13/13	13/13
EVAPORATOR, TUBE IN SHELL HYBRID FALLING FILM ²					
Water Volume, gal	96	130	96	96	147
Leaving Water Temperature (Min/Max), °F ³	40/60				
Air on Condenser (Min/Max), °F	0/125				
Maximum Water Side Pressure, psig	150				
Optional 300 psi Maximum Water Side Pressure, psig	300				
Maximum refrigerant Side Pressure, psig	235				
Evaporator Drain Connection, in	3/4"				
Minimum Chilled Water Flow rate-standard two pass, gpm	460	520	460	460	550
Maximum Chilled Water Flow rate-standard two pass, gpm	1540	1700	1540	1540	1880
Minimum Chilled Water Flow rate-optional one pass, gpm	-	-	-	-	-
Maximum Chilled Water Flow rate-optional one pass, gpm	-	-	-	-	-
Minimum Chilled Water Flow rate-optional three pass, gpm	310	350	310	310	400
Maximum Chilled Water Flow rate-optional three pass, gpm	1070	1200	1070	1070	1400
Inlet and outlet Water Connections-standard two pass, in	8	8	8	8	8
Inlet and outlet Water Connections-optional one pass, in	-	-	-	-	-
Inlet and outlet Water Connections-optional three pass, in	6	6	6	6	8

NOTES:

- Shipping and operating weights shown are for base unit; selected options may add weight to unit. Contact your nearest Johnson Controls Sales office for weight data.
- The evaporator is protected against freezing to 0°F (-17.8°C) with a standard heater.
- For leaving liquid temperature below 40°F (4.4°C) or above 60°F (15.6°C), contact your nearest Johnson Controls Sales Office for application requirements.

TABLE 6- PHYSICAL DATA (SI)

The data shown in this table is applicable to selected typical configurations. Other configurations are available through our configuration/selection software. Please contact your nearest Johnson Controls Sales Office for the chiller configuration that best matches your specific needs.

UNIT FRAME	015	016	017	018	019	019	020	021	021	021	023	024	024
CONDENSER CODE	3	5	8	3	5	8	0	3	5	8	3	5	8
EVAPORATOR CODE	B	B	C	A	A	B	C	A	C	C	B	C	C
GENERAL UNIT DATA													
Number of Independent refrigerant Circuits	2												
Refrigerant Charge, R-134a, Circuit -1, kg	80	86	102	80	86	100	93	80	102	109	96	114	114
Refrigerant Charge, R-134a, Circuit -2, kg	80	86	102	70	78	89	93	80	102	109	86	102	114
Oil Charge, Circuit -1, liters	7.7	8.4	9.5	9.2	9.9	10.3	9.9	9.5	10.6	11	10.3	11.1	11
Oil Charge, Circuit -2, liters	7.7	8.4	9.5	7.7	8	8.4	9.9	9.5	10.6	11	9.9	10.6	11
% minimum Load	10%												
Unit Shipping Weight, kg ¹	5224	5481	6653	5452	5797	6248	6074	5833	6765	7111	6027	7200	7545
Operating Weight, kg ¹	5434	5691	7000	5652	5997	6458	6421	6033	7111	7457	6237	7546	7891
Chassis Dimensions - Length, mm	5163	6280	7397	6279	7397	8514	5741	7397	7397	8514	7397	8514	9631
Chassis Dimensions - Width, mm	2244	2244	2244	2244	2244	2244	2244	2244	2244	2244	2244	2244	2244
Chassis Dimensions - Height, mm	2402	2402	2402	2402	2402	2402	2402	2402	2402	2402	2402	2402	2402
COMPRESSORS, SEMI-HERMETIC SCREW													
Quantity per Chiller	2												
CONDENSER FANS													
Number Ckt-1/Ckt-2	4/4	5/5	6/6	6/4	7/5	8/6	4/4	6/6	6/6	7/7	7/5	8/6	8/8
EVAPORATOR, TUBE IN SHELL HYBRID FALLING FILM²													
Water Volume, liters	220	220	269	182	182	220	269	182	269	269	220	269	269
Leaving Water Temperature (Min/Max), °C ³	4.4/15.6												
Air on Condenser (Min/Max), °C	-17.8/51.7												
Maximum Water Side Pressure, barg	10.3												
Optional 300 psi Maximum Water Side Pressure, barg	20.6												
Maximum refrigerant Side Pressure, bar	16.2												
Evaporator Drain Connection, in	3/4"												
Minimum Chilled Water Flow rate- standard two pass, l/sec	15.8	15.8	18.9	12.6	12.6	15.8	18.9	12.6	18.9	18.9	15.8	18.9	18.9
Maximum Chilled Water Flow rate- standard two pass, l/sec	59.9	59.9	72.6	47.3	47.3	59.9	72.6	47.3	72.6	72.6	59.9	72.6	72.6
Minimum Chilled Water Flow rate- optional one pass, l/sec	31.6	31.6	37.8	25.2	25.2	31.6	37.8	25.2	37.8	37.8	31.6	37.8	37.8
Maximum Chilled Water Flow rate- optional one pass, l/sec	119.8	119.8	145.2	94.6	94.6	119.8	145.2	94.6	145.2	145.2	119.8	145.2	145.2
Minimum Chilled Water Flow rate- optional three pass, l/sec	10.1	10.1	12.6	7.6	7.6	10.1	12.6	7.6	12.6	12.6	10.1	12.6	12.6
Maximum Chilled Water Flow rate- optional three pass, l/sec	37.9	37.9	47.3	31.5	31.5	37.9	47.3	31.5	47.3	47.3	37.9	47.3	47.3
Inlet and outlet Water Connections- standard two pass, in	6	6	6	6	6	6	6	6	6	6	6	6	6
Inlet and outlet Water Connections- optional one pass, in	8	8	8	6	6	8	8	6	8	8	8	8	8
Inlet and outlet Water Connections- optional three pass, in	5	5	6	5	5	5	6	5	6	6	5	6	6

NOTES:

- Shipping and operating weights shown are for base unit; selected options may add weight to unit. Contact your nearest Johnson Controls Sales office for weight data.
- The evaporator is protected against freezing to 0°F (-17.8°C) with a standard heater.
- For leaving liquid temperature below 40°F (4.4°C) or above 60°F (15.6°C), contact your nearest Johnson Controls Sales Office for application requirements.

TABLE 6 - PHYSICAL DATA (SI) (CONT'D)

The data shown in this table is applicable to selected typical configurations. Other configurations are available through our configuration/selection software. Please contact your nearest Johnson Controls Sales Office for the chiller configuration that best matches your specific needs.

UNIT FRAME	026	027	027	027	029	030	030	030	031	032	033	034	034
CONDENSER CODE	3	3	5	8	5	3	5	8	8	3	3	3	5
EVAPORATOR CODE	B	D	E	E	E	C	C	E	E	E	C	E	E
GENERAL UNIT DATA													
Number of Independent refrigerant Circuits	2												
Refrigerant Charge, R-134a, Circuit -1, kg	96	121	121	123	141	132	134	143	143	134	132	141	143
Refrigerant Charge, R-134a, Circuit -2, kg	96	121	121	123	121	112	114	125	134	134	132	141	143
Oil Charge, Circuit -1, liters	10.3	11.4	11.4	11.8	15.9	15.6	15.6	16.3	16.3	15.6	15.6	15.9	16.3
Oil Charge, Circuit -2, liters	10.3	11.4	11.4	11.8	11.8	11.4	11.4	12.2	12.5	15.6	15.6	15.9	16.3
% minimum Load	10%												
Unit Shipping Weight, kg ¹	6385	7382	7707	8052	8258	7763	8603	8603	8948	8416	8266	8761	9107
Operating Weight, kg ¹	6594	7758	8097	8442	8648	8109	8993	8993	9339	8806	8612	9151	9497
Chassis Dimensions - Length, mm	8514	8514	8514	9631	9631	9631	10748	10748	11865	9631	10748	10748	11865
Chassis Dimensions - Width, mm	2244	2244	2244	2244	2244	2244	2244	2244	2244	2244	2244	2244	2244
Chassis Dimensions - Height, mm	2402	2402	2402	2402	2402	2402	2402	2402	2402	2402	2402	2402	2402
COMPRESSORS, SEMI-HERMETIC SCREW													
Quantity per Chiller	2												
CONDENSER FANS													
Number Ckt-1/Ckt-2	7/7	7/7	7/7	8/8	9/7	9/7	10/8	10/8	10/10	8/8	9/9	9/9	10/10
EVAPORATOR, TUBE IN SHELL HYBRID FALLING FILM ²													
Water Volume, liters	220	310	428	428	428	269	269	428	428	428	269	428	428
Leaving Water Temperature (Min/Max), °C ³	4.4/15.6												
Air on Condenser (Min/Max), °C	-17.8/51.7												
Maximum Water Side Pressure, barg	10.3												
Optional 300 psi Maximum Water Side Pressure, barg	20.6												
Maximum refrigerant Side Pressure, bar	16.2												
Evaporator Drain Connection, in	3/4"												
Minimum Chilled Water Flow rate- standard two pass, l/sec	15.8	18.9	25.2	25.2	25.2	18.9	18.9	25.2	25.2	25.2	18.9	25.2	25.2
Maximum Chilled Water Flow rate- standard two pass, l/sec	59.9	72.6	94.7	94.7	94.7	72.6	72.6	94.7	94.7	94.7	72.6	94.7	94.7
Minimum Chilled Water Flow rate- optional one pass, l/sec	31.6	37.8	50.4	50.4	50.4	37.8	37.8	50.4	50.4	50.4	37.8	50.4	50.4
Maximum Chilled Water Flow rate- optional one pass, l/sec	119.8	145.2	189.4	189.4	189.4	145.2	145.2	189.4	189.4	189.4	145.2	189.4	189.4
Minimum Chilled Water Flow rate- optional three pass, l/sec	10.1	12.6	18.9	18.9	18.9	12.6	12.6	18.9	18.9	18.9	12.6	18.9	18.9
Maximum Chilled Water Flow rate- optional three pass, l/sec	37.9	47.3	53.6	53.6	53.6	47.3	47.3	53.6	53.6	53.6	47.3	53.6	53.6
Inlet and outlet Water Connections- standard two pass, in	6	6	8	8	8	6	6	8	8	8	6	8	8
Inlet and outlet Water Connections- optional one pass, in	8	8	10	10	10	8	8	10	10	10	8	10	10
Inlet and outlet Water Connections- optional three pass, in	5	6	6	6	6	6	6	6	6	6	6	6	6

NOTES:

- Shipping and operating weights shown are for base unit; selected options may add weight to unit. Contact your nearest Johnson Controls Sales office for weight data.
- The evaporator is protected against freezing to 0°F (-17.8°C) with a standard heater.
- For leaving liquid temperature below 40°F (4.4°C) or above 60°F (15.6°C), contact your nearest Johnson Controls Sales Office for application requirements.

ABLE 6 - PHYSICAL DATA (SI) (CONT'D)

The data shown in this table is applicable to selected typical configurations. Other configurations are available through our configuration/selection software. Please contact your nearest Johnson Controls Sales Office for the chiller configuration that best matches your specific needs.

UNIT FRAME	037	041	044	048	052
CONDENSER CODE	3	3	3	3	3
EVAPORATOR CODE	F	H	G	G	J
GENERAL UNIT DATA					
Number of Independent refrigerant Circuits	2				
Refrigerant Charge, R-134a, Circuit - 1, kg	190	290	168	175	202
Refrigerant Charge, R-134a, Circuit - 2, kg	111	156	168	175	202
Oil Charge, Circuit -1, liters	20	20.8	18.9	19.3	20.4
Oil Charge, Circuit -2, liters	10.9	16.2	18.9	19.3	20.4
% minimum Load	10%				
Unit Shipping Weight, kg ¹	10136	9635	11767	12113	12894
Operating Weight, kg ¹	10616	10001	12247	12593	13500
Chassis Dimensions - Length, mm	11865	11865	11865 / 2240	11865 / /3357	11865 / /3357
Chassis Dimensions - Width, mm	2248	2248	2248	2248	2248
Chassis Dimensions - Height, mm	2407	2407	2407	2407	2407
COMPRESSORS, SEMI-HERMETIC SCREW					
Quantity per Chiller	2				
CONDENSER FANS					
Number Ckt-1/Ckt-2	13/7	12/8	12/12	13/13	13/13
EVAPORATOR, TUBE IN SHELL HYBRID FALLING FILM²					
Water Volume, liters	363	492	363	363	556
Leaving Water Temperature (Min/Max), °C ³	4.4/15.6				
Air on Condenser (Min/Max), °C	17.8/51.7				
Maximum Water Side Pressure, barg	10.3				
Optional 300 psi Maximum Water Side Pressure, barg	20.6				
Maximum refrigerant Side Pressure, bar	16.2				
Evaporator Drain Connection, in	3/4"				
Minimum Chilled Water Flow rate-standard two pass, l/sec	29	33	29	29	35
Maximum Chilled Water Flow rate-standard two pass, l/sec	97	107	97	97	119
Minimum Chilled Water Flow rate-optional one pass, l/sec	-	-	-	-	-
Maximum Chilled Water Flow rate-optional one pass, l/sec	-	-	-	-	-
Minimum Chilled Water Flow rate-optional three pass, l/sec	20	22	20	20	25
Maximum Chilled Water Flow rate-optional three pass, l/sec	68	76	68	68	88
Inlet and outlet Water Connections-standard two pass, in	8	8	8	8	8
Inlet and outlet Water Connections-optional one pass, in	-	-	-	-	-
Inlet and outlet Water Connections-optional three pass, in	6	6	6		8

NOTES:

- Shipping and operating weights shown are for base unit; selected options may add weight to unit. Contact your nearest Johnson Controls Sales office for weight data.
- The evaporator is protected against freezing to 0°F (-17.8°C) with a standard heater.
- For leaving liquid temperature below 40°F (4.4°C) or above 60°F (15.6°C), contact your nearest Johnson Controls Sales Office for application requirements.

DIMENSIONS

The data shown in this table is applicable to selected typical configurations. Other configurations are available through our configuration/selection software. Please contact your nearest Johnson Controls Sales Office for the chiller configuration that best matches your specific needs.

ENGLISH AND SI DIMENSIONS

2 pass evaporator configuration

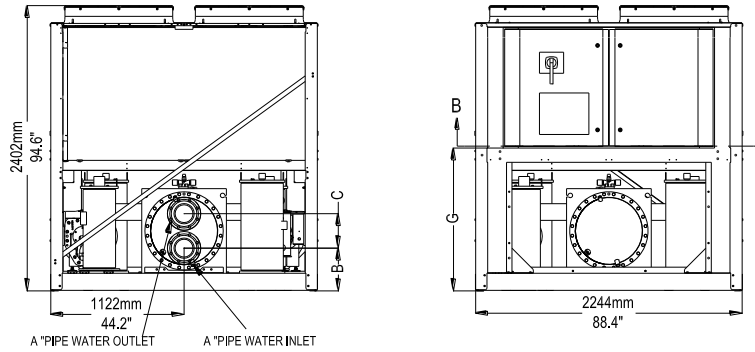

3 pass evaporator configuration

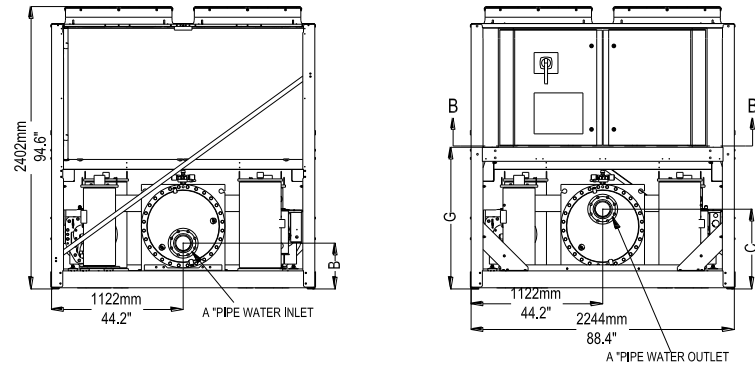

1 pass evaporator configuration

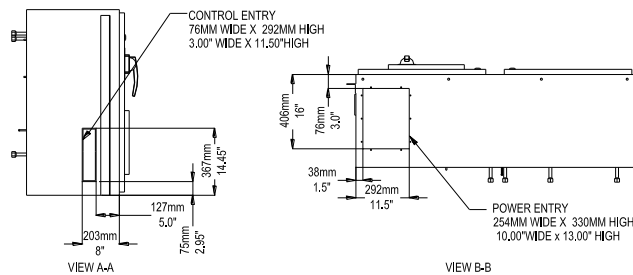
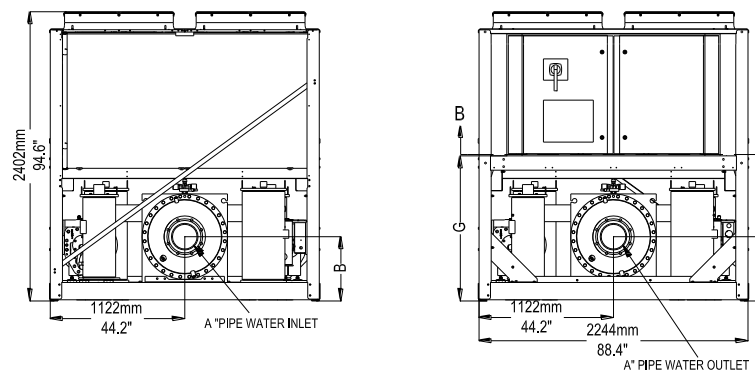
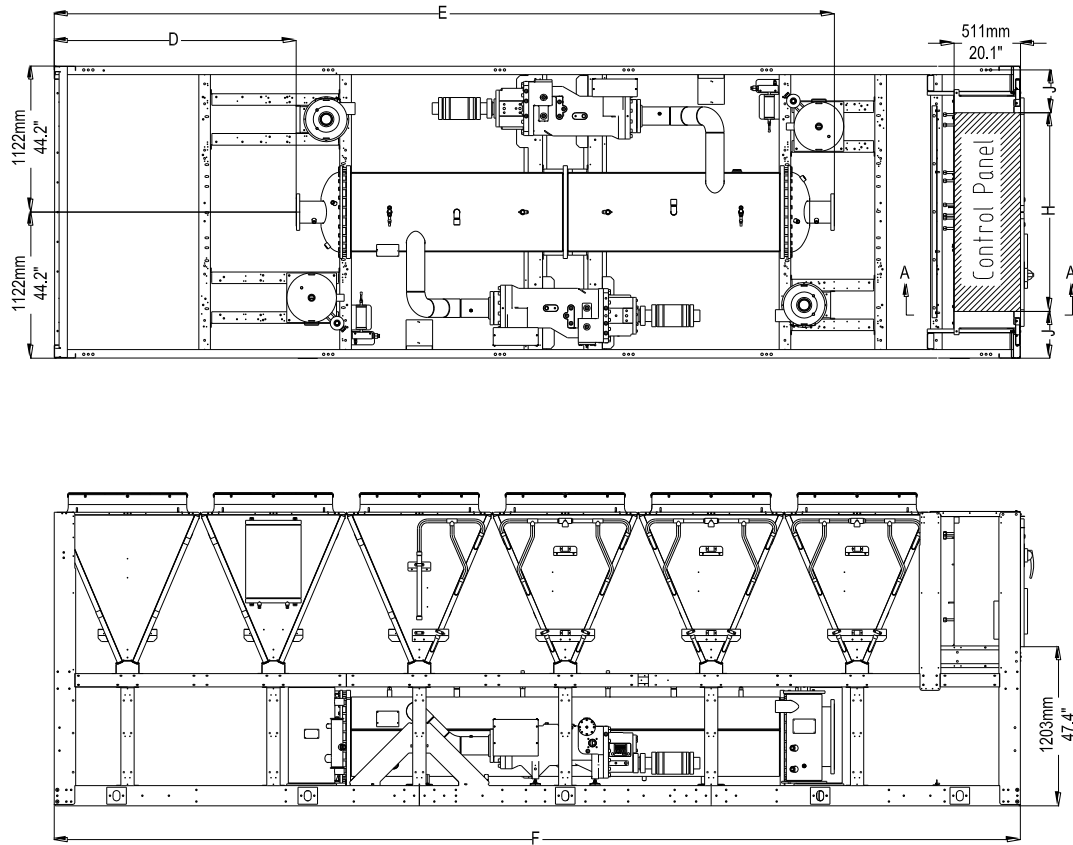

FIGURE 15- DIMENSIONS

The data shown in this table is applicable to selected typical configurations. Other configurations are available through our configuration/selection software. Please contact your nearest Johnson Controls Sales Office for the chiller configuration that best matches your specific needs.



Notes:

1. VSD / Control Panel doors extend beyond the end of the unit base by 54 mm (2-1/8").
2. Optional circuit breaker handle extends beyond the end of the unit base by 102 mm (4").
3. The drawings indicate dimensions for the listed standard configurations. For other configurations, please contact your nearest Johnson Controls Sales Office.

FIGURE15-DIMENSIONS(CONT'D)

The data shown in this table is applicable to selected typical configurations. Other configurations are available through our configuration/selection software. Please contact your nearest Johnson Controls Sales Office for the chiller configuration that best matches your specific needs.

TABLE 7- DIMENSIONS

YVAA MODEL			A			B		C		B		C		B		C	
FRAME	COND	EVAP	IN	IN	IN	IN	MM	IN	MM	IN	MM	IN	MM	IN	MM	IN	MM
			ONE PASS	TWO PASS	THREE PASS	1 PASS		2 PASS		3 PASS							
015	3	B	8	6	5	15.2	385	26.6	675	15.2	385	11.4	290	20.9	530	20.9	530
016	5	B	8	6	5	15.2	386	26.6	676	15.2	386	11.4	290	20.9	531	20.9	531
017	8	C	8	6	6	15.2	385	26.6	675	15.2	385	11.4	290	20.9	530	20.9	530
018	3	A	6	6	5	14.2	360	25.6	650	14.2	360	11.4	290	19.9	505	19.9	505
019	5	A	6	6	5	14.2	360	25.6	650	14.2	360	11.4	290	19.9	505	19.9	505
019	8	B	8	6	5	15.4	390	26.8	680	15.4	390	11.4	290	21.1	535	21.1	535
020	0	C	8	6	6	15.5	394	11.4	290	15.5	394	11.4	290	15.5	394	11.4	290
021	3	A	6	6	5	14.2	360	25.6	650	14.2	360	11.4	290	19.9	505	19.9	505
021	5	C	8	6	6	15.2	385	26.6	675	15.2	385	11.4	290	20.9	530	20.9	530
021	8	C	8	6	6	15.4	390	26.8	680	15.4	390	11.4	290	21.1	535	21.1	535
023	3	B	8	6	5	15.2	385	26.6	675	15.2	385	11.4	290	20.9	530	20.9	530
024	5	C	8	6	6	15.4	390	26.8	680	15.4	390	11.4	290	21.1	535	21.1	535
024	8	C	8	6	6	15.4	390	26.8	680	15.4	390	11.4	290	21.1	535	21.1	535
026	3	B	8	6	5	15.4	390	26.8	680	15.4	390	11.4	290	21.1	535	21.1	535
027	3	D	8	6	6	15.4	390	26.8	680	15.4	390	11.4	290	21.1	535	21.1	535
027	5	E	10	8	6	15.6	396	29.6	751	15.6	396	14.0	355	22.6	573	22.6	573
027	8	E	10	8	6	15.6	396	29.6	751	15.6	396	14.0	355	22.6	573	22.6	573
029	5	E	10	8	6	15.6	396	29.6	751	15.6	396	14.0	355	22.6	573	22.6	573
030	3	C	8	6	6	15.4	390	26.8	680	15.4	390	11.4	290	21.1	535	21.1	535
030	5	C	8	6	6	15.4	390	26.8	680	15.4	390	11.4	290	21.1	535	21.1	535
030	8	E	10	8	6	15.6	396	29.6	751	15.6	396	14.0	355	22.6	573	22.6	573
031	8	E	10	8	6	15.6	396	29.6	751	15.6	396	14.0	355	22.6	573	22.6	573
032	3	E	10	8	6	15.6	396	29.6	751	15.6	396	14.0	355	22.6	573	22.6	573
033	3	C	8	6	6	15.4	390	26.8	680	15.4	390	11.4	290	21.1	535	21.1	535
034	3	E	10	8	6	15.6	396	29.6	751	15.6	396	14.0	355	22.6	573	22.6	573
034	5	E	10	8	6	15.6	396	29.6	751	15.6	396	14.0	355	22.6	573	22.6	573
037	3	F	10	8	6	15.6	396	22.3	567	15.6	396	13.0	330	15.8	402	44.2	1122
041	3	H	10	8	6	15.6	396	22.3	567	15.6	396	14.0	355	15.5	394	44.2	1122
044	3	G	10	8	6	15.6	396	22.3	567	15.6	396	13.0	330	15.8	402	44.2	1122
048	3	G	10	8	6	15.6	396	22.3	567	15.6	396	13.0	330	15.8	402	44.2	1122
052	3	J	10	8	8	16.3	414	23.3	592	16.3	414	14.0	355	16.3	414	16.3	769

The data shown in this table is applicable to selected typical configurations. Other configurations are available through our configuration/selection software. Please contact your nearest Johnson Controls Sales Office for the chiller configuration that best matches your specific needs.

TABLE 7 - DIMENSIONS(CONT'D)

YVAA MODEL			D		E		F		H		J	
FRAME	COND	EVAP	IN	MM	IN	MM	IN	MM	IN	MM	IN	MM
015	3	B	6.6	167	168.8	4287	203.3	5163	60.0	1524	14.1	359
016	5	B	29.0	735	191.2	4855	247.2	6280	60.0	1524	14.1	359
017	8	C	34.7	882	221.5	5626	291.2	7397	60.0	1524	14.1	359
018	3	A	18.2	463	189.9	4823	247.2	6279	60.0	1524	14.1	359
019	5	A	62.3	1582	233.9	5942	291.2	7397	60.0	1524	14.1	359
019	8	B	116.9	2970	279.1	7090	335.2	8514	60.0	1524	14.1	359
020	0	C	1.7	43	187.7	4767	226.0	5741	60.0	1524	14.1	359
021	3	A	62.3	1582	233.9	5942	291.2	7397	60.0	1524	14.1	359
021	5	C	34.7	882	221.5	5626	291.2	7397	60.0	1524	14.1	359
021	8	C	78.7	1999	265.5	6743	335.2	8514	60.0	1524	14.1	359
023	3	B	72.9	1853	235.1	5973	291.2	7397	60.0	1524	14.1	359
024	5	C	92.6	2353	279.4	7097	335.2	8514	60.0	1524	14.1	359
024	8	C	122.6	3115	309.4	7859	379.2	9631	60.0	1524	14.1	359
026	3	B	116.7	2970	279.1	7090	335.2	8514	60.0	1524	14.1	359
027	3	D	42.7	1085	265.1	6734	335.2	8514	60.0	1524	14.1	359
027	5	E	44.1	1120	264.0	6705	335.2	8514	60.0	1524	14.1	359
027	8	E	88.0	2235	308.1	7827	379.2	9631	60.0	1524	14.1	359
029	5	E	88.0	2234	307.8	7819	379.2	9631	70.0	1778	9.1	232
030	3	C	122.7	3117	309.1	7851	379.2	9631	70.0	1778	9.1	232
030	5	C	166.7	4234	353.1	8968	423.1	10748	70.0	1778	9.1	232
030	8	E	131.9	3351	351.8	8936	423.1	10748	70.0	1778	9.1	232
031	8	E	175.9	4468	395.8	10053	467.1	11865	70.0	1778	9.1	232
032	3	E	88.0	2234	307.8	7819	379.2	9631	70.0	1778	9.1	232
033	3	C	166.7	4234	353.1	8968	423.1	10748	70.0	1778	9.1	232
034	3	E	131.9	3351	351.8	8936	423.1	10748	70.0	1778	9.1	232
034	5	E	175.9	4468	395.8	10053	467.1	11865	70.0	1778	9.1	232
037	3	F	180.9	4595	354.9	9015	467.1	11865	88.0	2235	0.14	3.5
041	3	H	164.6	4180	383.3	9737	467.1	11865	88.0	2235	0.14	3.5
044	3	G	287.1	7292	461.1	11712	467.1 /88.2	11865 /2240	88.0	2235	0.14	3.5
048	3	G	331.0	8409	505.1	12829	467.1 /132	11865 /3357	88.0	2235	0.14	3.5
052	3	J	309.1	7852	528.3	13421	467.1 /132	11865 /3357	88.0	2235	0.14	3.5

TABLE 8- RIGGING HOLE LOCATIONS (ENGLISH)

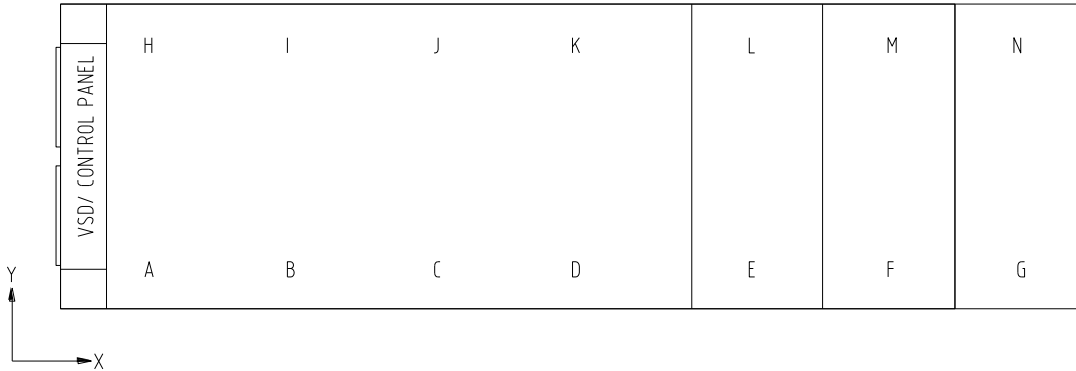

YVAA MODEL			DESCRIPTION	A	B	C	D	E	F	G	H	I	J	K	L	M	N	CENTER OF GRAVITY	
FRAME	CONDENSER	EVAPORATOR																X	Y
015	3	B	rigging Hole Location / (inch)	18	60	116	192	-	-	-	18	60	116	192	-	-	-	102	44
			Point Load (lbs)	1035	1676	1676	1372	-	-	-	951	1656	1656	1495	-	-	-	-	-
016	5	B	rigging Hole Location / (inch)	18	60	137	214	-	-	-	18	60	137	214	-	-	-	126	44
			Point Load (lbs)	624	1139	3081	1198	-	-	-	606	1120	3057	1259	-	-	-	-	-
017	8	C	rigging Hole Location / (inch)	12	73	144	197	260	-	-	12	73	144	197	260	-	-	144	44
			Point Load (lbs)	625	1746	2573	1287	1103	-	-	634	1612	2611	1305	1172	-	-	-	-
018	3	A	rigging Hole Location / (inch)	18	60	143	220	-	-	-	18	60	143	220	-	-	-	128	44
			Point Load (lbs)	504	1448	2890	1142	-	-	-	510	1416	2917	1192	-	-	-	-	-
019	5	A	rigging Hole Location / (inch)	18	60	143	227	272	-	-	18	60	143	227	272	-	-	139	44
			Point Load (lbs)	469	1474	2778	1389	256	-	-	484	1422	2831	1416	264	-	-	-	-
019	8	B	rigging Hole Location / (inch)	18	60	137	215	302	-	-	18	60	137	215	302	-	-	148	44
			Point Load (lbs)	416	1628	2445	1657	717	-	-	396	1631	2453	1716	717	-	-	-	-
020	0	C	rigging Hole Location / (inch)	18	60	131	214	-	-	-	18	60	131	214	-	-	-	120	44
			Point Load (lbs)	1199	750	3466	1280	-	-	-	1107	776	3428	1384	-	-	-	-	-
021	3	A	rigging Hole Location / (inch)	18	60	143	227	272	-	-	18	60	143	227	272	-	-	139	44
			Point Load (lbs)	472	1467	2822	1411	257	-	-	484	1419	2841	1420	264	-	-	-	-
021	5	C	rigging Hole Location / (inch)	12	73	144	197	260	-	-	12	73	144	197	260	-	-	150	44
			Point Load (lbs)	480	1988	1988	1688	1314	-	-	472	1935	1935	1736	1379	-	-	-	-
021	8	C	rigging Hole Location / (inch)	12	73	163	254	324	-	-	12	73	163	254	324	-	-	153	44
			Point Load (lbs)	518	2344	3047	1501	428	-	-	510	2282	2967	1743	336	-	-	-	-
023	3	B	rigging Hole Location / (inch)	18	60	137	215	272	-	-	18	60	137	215	272	-	-	135	44
			Point Load (lbs)	340	2054	2049	2049	143	-	-	329	2038	2067	2067	151	-	-	-	-
024	5	C	rigging Hole Location / (inch)	18	60	149	240	324	-	-	18	60	149	240	324	-	-	152	44
			Point Load (lbs)	358	2130	2982	2151	307	-	-	354	2079	2911	2340	261	-	-	-	-
024	8	C	rigging Hole Location / (inch)	12	73	163	254	347	-	-	12	73	163	254	347	-	-	169	44
			Point Load (lbs)	697	1921	3078	1741	871	-	-	697	1800	3169	1773	886	-	-	-	-

TABLE 8 - RIGGING HOLE LOCATIONS (ENGLISH) (CONT'D)

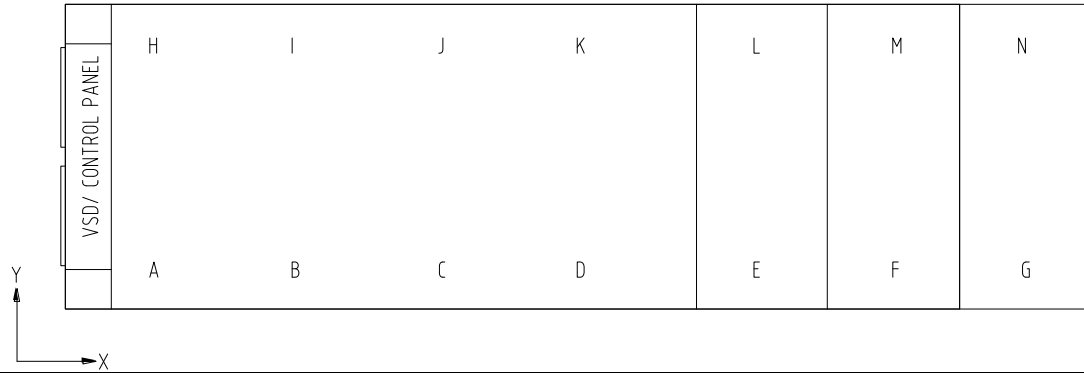

YVAA MODEL			DESCRIPTION	A	B	C	D	E	F	G	H	I	J	K	L	M	N	CENTER OF GRAVITY	
FRAME	CONDENSER	EVAPORATOR																X	Y
026	3	B	rigging Hole Location / (inch)	18	60	137	215	302	—	—	18	60	137	215	302	—	—	146	44
			Point Load (lbs)	513	1610	2517	1681	717	—	—	490	1620	2489	1722	717	—	—	—	—
027	3	D	rigging Hole Location / (inch)	12	73	121	181	264	324	—	12	73	121	181	264	324	—	168	44
			Point Load (lbs)	877	553	1442	3605	1108	554	—	808	570	1411	3527	1214	607	—	—	—
027	5	E	rigging Hole Location / (inch)	12	73	121	181	264	324	—	12	73	121	181	264	324	—	168	44
			Point Load (lbs)	872	569	1524	3811	1146	573	—	803	587	1493	3734	1252	626	—	—	—
027	8	E	rigging Hole Location / (inch)	12	73	121	181	243	347	—	12	73	121	181	243	347	—	178	44
			Point Load (lbs)	616	1372	1138	2845	1937	968	—	542	1407	1099	2747	2054	1027	—	—	—
029	5	E	rigging Hole Location / (inch)	12	73	179	290	347	—	—	12	73	179	290	347	—	—	177	44
			Point Load (lbs)	500	1930	4518	1506	533	—	—	434	1937	4698	1566	583	—	—	—	—
030	3	C	rigging Hole Location / (inch)	12	73	161	254	347	—	—	12	73	161	254	347	—	—	168	44
			Point Load (lbs)	747	1875	3196	1749	874	—	—	747	1784	3464	1785	893	—	—	—	—
030	5	C	rigging Hole Location / (inch)	12	73	161	254	306	391	—	12	73	161	254	306	391	—	180	44
			Point Load (lbs)	559	2024	3021	2164	302	752	—	411	2226	2990	2374	299	752	—	—	—
030	8	E	rigging Hole Location / (inch)	12	73	121	179	243	296	391	12	73	121	179	243	296	391	204	44
			Point Load (lbs)	1113	323	2182	2182	1309	1505	753	1073	398	2162	2162	1547	1505	753	—	—
031	8	E	rigging Hole Location / (inch)	12	73	121	179	243	353	435	12	73	121	179	243	353	435	210	44
			Point Load (lbs)	1028	575	2009	2009	2022	1580	527	988	650	1988	1988	2259	1580	527	—	—
032	3	E	rigging Hole Location / (inch)	12	73	121	181	243	347	—	12	73	121	181	243	347	—	177	44
			Point Load (lbs)	701	1261	1250	3125	1960	980	—	604	1370	1204	3010	2060	1030	—	—	—
033	3	C	rigging Hole Location / (inch)	12	73	163	254	306	391	—	12	73	163	254	306	391	—	180	44
			Point Load (lbs)	550	2052	3327	2098	333	752	—	373	2354	2951	2387	295	752	—	—	—
034	3	E	rigging Hole Location / (inch)	12	73	121	181	243	296	391	12	73	121	181	243	296	391	204	44
			Point Load (lbs)	1087	408	2224	2224	1456	1505	753	1038	514	2135	2135	1578	1505	753	—	—
034	5	E	rigging Hole Location / (inch)	12	73	121	181	243	353	435	12	73	121	181	243	353	435	210	44
			Point Load (lbs)	1002	659	2048	2048	2173	1580	527	953	765	1959	1959	2295	1580	527	—	—

5

TABLE 8 - RIGGING HOLE LOCATIONS (ENGLISH) (CONT'D)

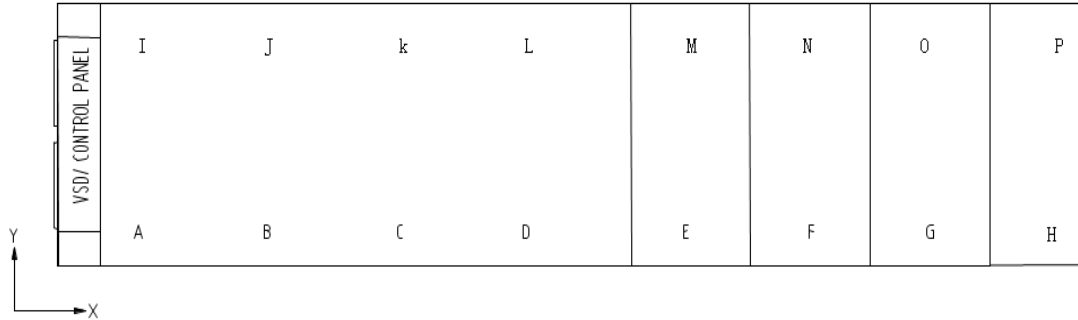

YVAA MODEL			DESCRIPTION	A	B	C	D	E	F	G	H	I	J	K	L	M	N	O	P	CENTER OF GRAVITY	
FRAME	CONDENSER	EVAPORATOR																		X	Y
037	3	F	rigging Hole Location / (inch)	12	73	181	238	302	435	—	—	12	73	181	238	302	435	—	—	210	49
			Point Load (lbs)	396	2152	4507	396	2142	881	—	—	368	2116	5853	368	2287	881	—	—	—	—
041	3	H	rigging Hole Location / (inch)	12	73	181	238	302	435	—	—	12	73	181	238	302	435	—	—	219	48
			Point Load (lbs)	314	1845	4601	6039	7662	11059	—	—	314	1845	4601	6039	7662	11059	—	—	5563	1219
044	3	G	rigging Hole Location / (inch)	12	73	181	238	290	435	478	545	12	73	181	238	290	435	478	545	227	46
			Point Load (lbs)	314	1845	4602	6039	7662	11059	12135	13835	314	1845	4602	6039	7358	11059	12135	13835	5766	1168
048	3	G	rigging Hole Location / (inch)	12	73	181	238	290	435	494	572	12	73	181	238	290	435	—	—	234	46
			Point Load (lbs)	314	1845	4602	6039	7358	11059	12546	14529	305	1854	4597	6045	7366	11049	—	—	5944	1168
052	3	J	rigging Hole Location / (inch)	12	73	181	238	290	435	494	572	12	73	181	238	290	435	494	572	234	46
			Point Load (lbs)	305	1854	4597	6045	7366	11049	12548	14529	305	1854	4597	6045	7366	11049	12548	14529	5944	1168

NOTE: Weights shown for base unit; selected options may add weight to unit. Contact your nearest Johnson Controls Sales Office for weight data

TABLE 9- RIGGING HOLE LOCATIONS (SI)

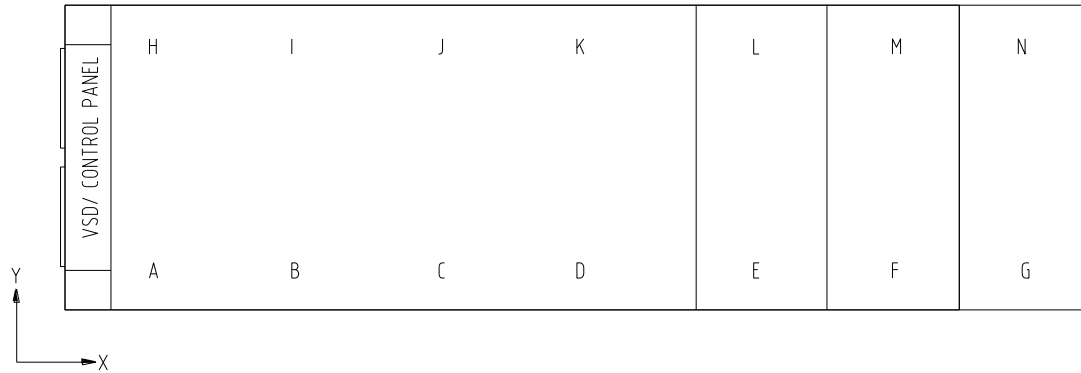

YVAA MODEL			DESCRIPTION	A	B	C	D	E	F	G	H	I	J	K	L	M	N	CENTER OF GRAVITY	
FRAME	CONDENSER	EVAPORATOR																X	Y
015	3	B	rigging Hole Location / (mm)	464	1512	2937	4866	—	—	—	464	1511	2937	4866	—	—	—	2578	1122
			Point Load (kgs)	470	760	760	622	—	—	—	431	751	751	678	—	—	—	—	—
016	5	B	rigging Hole Location / (mm)	464	1533	3485	5435	—	—	—	464	1533	3485	5435	—	—	—	3206	1122
			Point Load (kgs)	283	516	1397	543	—	—	—	275	508	1387	571	—	—	—	—	—
017	8	C	rigging Hole Location / (mm)	314	1845	3654	5012	6593	—	—	314	1845	3654	5012	6593	—	—	3649	1122
			Point Load (kgs)	283	792	1167	584	501	—	—	288	731	1184	592	532	—	—	—	—
018	3	A	rigging Hole Location / (mm)	464	1533	3636	5598	—	—	—	464	1533	3636	5598	—	—	—	3248	1122
			Point Load (kgs)	229	657	1311	518	—	—	—	231	642	1323	541	—	—	—	—	—
019	5	A	rigging Hole Location / (mm)	464	1533	3636	5761	6920	—	—	464	1533	3636	5761	6920	—	—	3523	1122
			Point Load (kgs)	213	669	1260	630	116	—	—	219	645	1284	642	120	—	—	—	—
019	8	B	rigging Hole Location / (mm)	464	1533	3484	5455	7670	—	—	464	1533	3484	5455	7670	—	—	3760	1122
			Point Load (kgs)	189	738	1109	751	325	—	—	180	740	1113	779	325	—	—	—	—
020	0	C	rigging Hole Location / (mm)	464	1518	3332	5430	—	—	—	464	1518	3332	5430	—	—	—	3049	1122
			Point Load (kgs)	544	340	1572	581	—	—	—	502	352	1555	628	—	—	—	—	—
021	3	A	rigging Hole Location / (mm)	464	1533	3637	5761	6920	—	—	464	1533	3637	5761	6920	—	—	3530	1122
			Point Load (kgs)	214	665	1280	640	117	—	—	220	644	1288	644	120	—	—	—	—
021	5	C	rigging Hole Location / (mm)	314	1845	3654	5012	6593	—	—	314	1845	3654	5012	6593	—	—	3806	1122
			Point Load (kgs)	218	902	902	766	596	—	—	214	878	878	788	626	—	—	—	—
021	8	C	rigging Hole Location / (mm)	314	1845	4144	6443	8218	—	—	314	1845	4144	6443	8218	—	—	3889	1124
			Point Load (kgs)	235	1063	1382	681	194	—	—	231	1035	1346	791	152	—	—	—	—
023	3	B	rigging Hole Location / (mm)	464	1533	3485	5456	6919	—	—	464	1533	3485	5456	6919	—	—	3418	1122
			Point Load (kgs)	154	932	929	929	65	—	—	149	925	938	938	69	—	—	—	—
024	5	C	rigging Hole Location / (mm)	464	1533	3789	6088	8218	—	—	464	1533	3789	6088	8218	—	—	3851	1122
			Point Load (kgs)	162	966	1352	975	139	—	—	160	943	1320	1061	118	—	—	—	—
024	8	C	rigging Hole Location / (mm)	314	1845	4144	6443	8825	—	—	314	1845	4144	6443	8825	—	—	4289	1122
			Point Load (kgs)	316	871	1396	790	395	—	—	316	817	1437	804	402	—	—	—	—

TABLE 9 - RIGGING HOLE LOCATIONS (SI) (CONT'D)

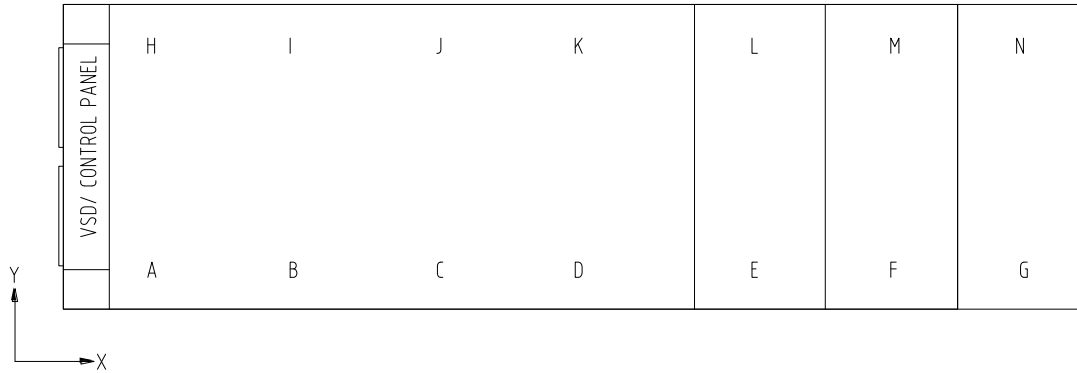

YVAA MODEL			DESCRIPTION	A	B	C	D	E	F	G	H	I	J	K	L	M	N	CENTER OF GRAVITY	
FRAME	CONDENSER	EVAPORATOR																X	Y
026	3	B	rigging Hole Location / (mm)	464	1533	3484	5455	7670	—	—	464	1533	3484	5455	7670	—	—	3721	1122
			Point Load (kgs)	233	730	1142	763	325	—	—	222	735	1129	781	325	—	—	—	—
027	3	D	rigging Hole Location / (mm)	314	1845	3073	4601	6717	8217	—	314	1845	3073	4601	6717	8217	—	4259	1122
			Point Load (kgs)	398	251	654	1635	502	251	—	366	259	640	1600	551	275	—	—	—
027	5	E	rigging Hole Location / (mm)	314	1845	3073	4601	6717	8218	—	314	1845	3073	4601	6717	8218	—	4274	1122
			Point Load (kgs)	396	258	691	1729	520	260	—	364	266	677	1694	568	284	—	—	—
027	8	E	rigging Hole Location / (mm)	314	1845	3073	4601	6169	8825	—	314	1845	3073	4601	6169	8825	—	4525	1122
			Point Load (kgs)	280	622	516	1290	878	439	—	246	638	498	1246	932	466	—	—	—
029	5	E	rigging Hole Location / (mm)	314	1845	4551	7358	8825	—	—	314	1845	4551	7358	8825	—	—	4495	1122
			Point Load (kgs)	227	875	2049	683	242	—	—	197	879	2131	710	264	—	—	—	—
030	3	C	rigging Hole Location / (mm)	314	1845	4092	6443	8825	—	—	314	1845	4092	6443	8825	—	—	4256	1122
			Point Load (kgs)	339	850	1450	793	397	—	—	339	809	1571	810	405	—	—	—	—
030	5	C	rigging Hole Location / (mm)	314	1845	4092	6443	7763	9941	—	314	1845	4092	6443	7763	9941	—	4566	1122
			Point Load (kgs)	253	918	1370	981	137	341	—	187	1010	1356	1077	136	341	—	—	—
030	8	E	rigging Hole Location / (mm)	314	1845	3072	4549	6169	7508	9942	314	1845	3072	4549	6169	7508	9942	5172	1122
			Point Load (kgs)	505	147	990	990	594	683	341	487	180	981	981	702	683	341	—	—
031	8	E	rigging Hole Location / (mm)	314	1845	3072	4549	6169	8962	11059	314	1845	3072	4549	6169	8962	11059	5341	1122
			Point Load (kgs)	466	261	911	911	917	717	239	448	295	902	902	1025	717	239	—	—
032	3	E	rigging Hole Location / (mm)	314	1845	3073	4601	6169	8825	—	314	1845	3073	4601	6169	8825	—	4504	1122
			Point Load (kgs)	318	572	567	1417	889	445	—	274	622	546	1365	934	467	—	—	—
033	3	C	rigging Hole Location / (mm)	314	1845	4144	6443	7765	9942	—	314	1845	4144	6443	7765	9942	—	4563	1122
			Point Load (kgs)	250	931	1509	952	151	341	—	169	1068	1338	1083	134	341	—	—	—
034	3	E	rigging Hole Location / (mm)	314	1845	3073	4602	6170	7511	9942	314	1845	3073	4602	6170	7511	9942	5172	1122
			Point Load (kgs)	493	185	1009	1009	660	683	341	471	233	968	968	716	683	341	—	—
034	5	E	rigging Hole Location / (mm)	314	1845	3073	4602	6170	8961	11059	314	1845	3073	4602	6170	8961	11059	5338	1122
			Point Load (kgs)	455	299	929	929	986	717	239	432	347	889	889	1041	717	239	—	—

TABLE 9 - RIGGING HOLE LOCATIONS (SI) (CONT'D)

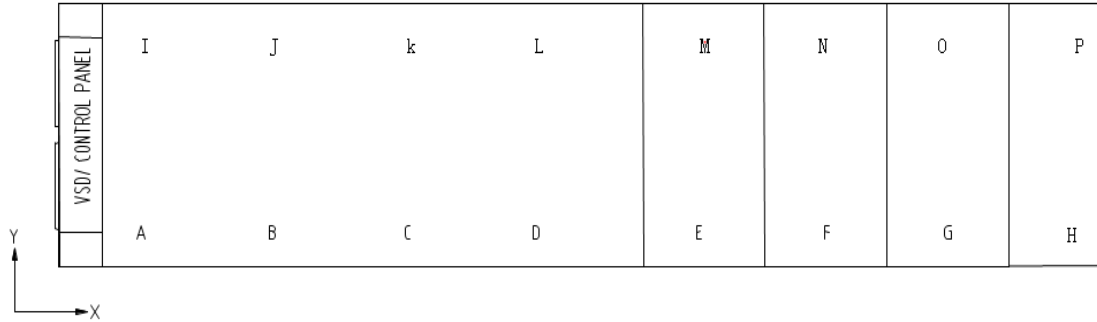

YVAA MODEL			DESCRIPTION	A	B	C	D	E	F	G	H	I	J	K	L	M	N	O	P	CENTER OF GRAVITY	
FRAME	CONDENSER	EVAPORATOR																		X	Y
037	3	F	rigging Hole Location / (mm)	314	1845	4602	6039	7662	11059	—	—	314	1845	4602	6039	7662	11059	—	—	5334	1245
			Point Load (Kg)	396	2152	4507	396	2142	881	—	—	368	2116	5853	368	2287	881	—	—	—	—
041	3	H	rigging Hole Location / (mm)	314	1845	4601	6039	7662	11059	—	—	314	1845	4601	6039	7662	11059	—	—	5563	1219
			Point Load (Kg)	192	918	1984	192	867	400	—	—	184	897	2508	184	911	400	—	—	—	—
044	3	G	rigging Hole Location / (mm)	314	1845	4602	6039	7662	11059	12135	13835	314	1845	4602	6039	7358	11059	12135	13835	5766	1168
			Point Load (Kg)	86	1339	2425	276	937	35	80	706	54	1372	2314	361	960	35	80	708	—	—
048	3	G	rigging Hole Location / (mm)	314	1845	4602	6039	7358	11059	12546	14529	305	1854	4597	6045	7366	11049	—	—	5944	1168
			Point Load (Kg)	153	1163	2683	47	1047	235	479	250	122	1193	2575	128	1074	235	479	250	—	—
052	3	J	rigging Hole Location / (mm)	305	1854	4597	6045	7366	11049	12548	14529	305	1854	4597	6045	7366	11049	12548	14529	5944	1168
			Point Load (Kg)	152	1407	2513	144	1266	235	478	250	119	1441	2402	225	1296	235	478	250	—	—

NOTE: Weights shown for base unit; selected options may add weight to unit. Contact your nearest Johnson Controls Sales Office for weight data

TABLE 10- ISOLATOR LOCATIONS (ENGLISH)

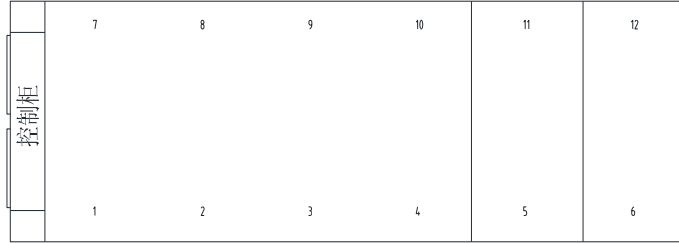

YVAA MODEL			DESCRIPTION	1	2	3	4	5	6	7	8	9	10	11	12
FRAME	COND	EVAPO													
015	3	B	Isolator X-Dimension / (inch)	10	73	144	193	—	—	10	73	144	193	—	—
			Isolator Y-Dimension / (inch)	1				—	87				—	—	
			Point Load (lbs)	1052	2147	2147	644	—	—	978	2116	2116	780	—	—
016	5	B	Isolator Y-Dimension / (mm)	263	1943	3000	3984	5589	—	263	1943	3000	3984	5589	—
			Isolator Y-Dimension / (mm)	32				—	2213				—	—	
			Point Load (lbs)	882	759	1790	1790	1052	—	863	731	1788	1788	1103	—
017	8	C	Isolator X-Dimension / (inch)	10	81	149	187	251	—	10	81	149	187	251	—
			Isolator Y-Dimension / (inch)	1				—	87				—	—	
			Point Load (lbs)	734	2308	1598	1598	1477	—	726	2201	1616	1616	1557	—
018	3	A	Isolator X-Dimension / (inch)	10	76	124	163	210	—	10	76	124	163	210	—
			Isolator Y-Dimension / (inch)	1				—	87				—	—	
			Point Load (lbs)	711	1659	1088	1088	1660	—	704	1654	1084	1084	1729	—
019	5	A	Isolator X-Dimension / (inch)	10	76	118	157	209	281	10	76	118	157	209	281
			Isolator Y-Dimension / (inch)	1				—	87				—	—	
			Point Load (lbs)	851	851	1311	2170	702	702	844	844	1286	2227	717	717
019	8	B	Isolator X-Dimension / (inch)	10	76	118	157	209	308	10	76	118	157	209	308
			Isolator Y-Dimension / (inch)	1				—	87				—	—	
			Point Load (lbs)	614	2113	659	659	2442	606	594	2130	649	649	2516	606
020	0	C	Isolator X-Dimension / (inch)	10	46	107	154	217	—	10	46	107	154	217	—
			Isolator Y-Dimension / (inch)	1				—	87				—	—	
			Point Load (lbs)	903	970	1964	1939	1302	—	833	964	1955	1928	1398	—
021	3	A	Isolator X-Dimension / (inch)	10	76	118	157	209	281	10	76	118	157	209	281
			Isolator Y-Dimension / (inch)	1				—	87				—	—	
			Point Load (lbs)	851	851	1317	2210	711	711	844	844	1287	2236	719	719
021	5	C	Isolator X-Dimension / (inch)	10	81	149	187	251	—	10	81	149	187	251	—
			Isolator Y-Dimension / (inch)	1				—	87				—	—	
			Point Load (lbs)	659	2075	1705	1705	1697	—	652	1990	1710	1710	1776	—
021	8	C	Isolator X-Dimension / (inch)	10	81	149	187	235	301	10	81	149	187	235	301
			Isolator Y-Dimension / (inch)	1	—	—	—	—	—	87	—	—	—	—	—
			Point Load (lbs)	717	2727	564	564	2431	1216	704	2650	571	571	2482	1241
023	3	B	Isolator X-Dimension / (inch)	10	76	118	157	209	281	10	76	118	157	209	281
			Isolator Y-Dimension / (inch)	1				—	87				—	—	
			Point Load (lbs)	947	947	1423	2230	659	659	933	933	1430	2247	670	670
024	5	C	Isolator X-Dimension / (inch)	10	76	128	173	220	301	10	76	128	173	220	301
			Isolator Y-Dimension / (inch)	1				—	87				—	—	
			Point Load (lbs)	813	1915	1459	1459	1775	887	807	1825	1482	1482	1821	910
024	8	C	Isolator X-Dimension / (inch)	10	81	143	187	245	339	10	81	143	187	245	339
			Isolator Y-Dimension / (inch)	1				—	87				—	—	
			Point Load (lbs)	661	1793	2030	2030	1088	1088	661	1645	2097	2097	1104	1104

TABLE 10 - ISOLATOR LOCATIONS (ENGLISH) (CONT'D)

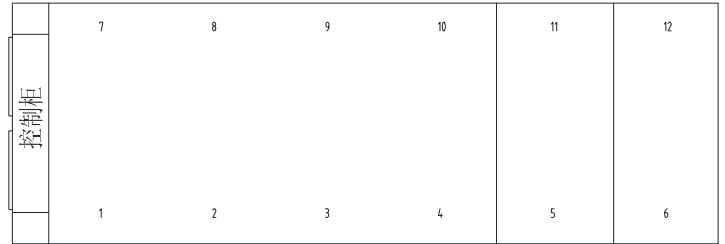

YVAA MODEL			DESCRIPTION	1	2	3	4	5	6	7	8	9	10	11	12	
FRAME	CONDE	EVAP														
026	3	B	Isolator X-Dimension / (inch)	10	76	118	157	209	308	10	76	118	157	209	308	
			Isolator Y-Dimension / (inch)	1						87						
			Point Load (lbs)	694	2119	689	689	2472	606	674	2135	666	666	2523	606	
027	3	D	Isolator X-Dimension / (inch)	10	81	161	201	301	—	10	81	161	201	301	—	
			Isolator Y-Dimension / (inch)	1						—	87					
			Point Load (lbs)	710	1539	2778	2135	1389	—	681	1372	3036	1946	1518	—	
027	5	E	Isolator X-Dimension / (inch)	10	81	161	201	301	—	10	81	161	201	301	—	
			Isolator Y-Dimension / (inch)	1						—	87					
			Point Load (lbs)	689	1641	2874	2283	1437	—	660	1474	3132	2093	1566	—	
027	8	E	Isolator X-Dimension / (inch)	10	81	161	201	298	339	10	81	161	201	298	339	
			Isolator Y-Dimension / (inch)	1						87						
			Point Load (lbs)	650	1770	2535	2535	908	908	596	1729	2529	2529	962	962	
029	5	E	Isolator X-Dimension / (inch)	10	81	161	201	296	339	10	81	161	201	296	339	
			Isolator Y-Dimension / (inch)	1						87						
			Point Load (lbs)	693	1821	2532	2532	919	919	629	1830	2621	2621	973	973	
030	3	C	Isolator X-Dimension / (inch)	10	81	143	187	245	339	10	81	143	187	245	339	
			Isolator Y-Dimension / (inch)	1						87						
			Point Load (lbs)	708	1803	2071	2071	1085	1085	708	1666	2245	2245	1095	1095	
030	5	C	Isolator X-Dimension / (inch)	10	81	144	187	277	383	10	81	144	187	277	383	
			Isolator Y-Dimension / (inch)	1						87						
			Point Load (lbs)	870	1451	2185	2185	1652	861	765	1551	2240	2240	1779	861	
030	8	E	Isolator X-Dimension / (inch)	10	81	161	201	298	383	10	81	161	201	298	383	
			Isolator Y-Dimension / (inch)	1						87						
			Point Load (lbs)	800	2001	2138	2138	1858	863	789	1968	2235	2235	1939	863	
031	8	E	Isolator X-Dimension / (inch)	10	81	161	201	298	427	10	81	161	201	298	427	
			Isolator Y-Dimension / (inch)	1						87						
			Point Load (lbs)	787	2033	2067	2067	2211	1013	777	2000	2164	2164	2292	1013	
032	3	E	Isolator X-Dimension / (inch)	10	81	161	201	298	339	10	81	161	201	298	339	
			Isolator Y-Dimension / (inch)	1						87						
			Point Load (lbs)	700	1767	2701	2701	919	919	633	1790	2678	2678	964	964	
033	3	C	Isolator X-Dimension / (inch)	10	81	143	188	245	383	10	81	143	188	245	383	
			Isolator Y-Dimension / (inch)	1						87						
			Point Load (lbs)	575	2930	891	891	3346	861	441	3177	707	707	3601	861	
034	3	E	Isolator X-Dimension / (inch)	10	81	161	201	298	383	10	81	161	201	298	383	
			Isolator Y-Dimension / (inch)	1						87						
			Point Load (lbs)	801	1995	2260	2260	1910	863	790	1966	2259	2259	1951	863	
034	5	E	Isolator X-Dimension / (inch)	10	81	161	201	298	427	10	81	161	201	298	427	
			Isolator Y-Dimension / (inch)	1						87						
			Point Load (lbs)	786	2025	2189	2189	2265	1014	775	1996	2188	2188	2307	1014	

5

TABLE 10 - ISOLATOR LOCATIONS (ENGLISH) (CONT'D)

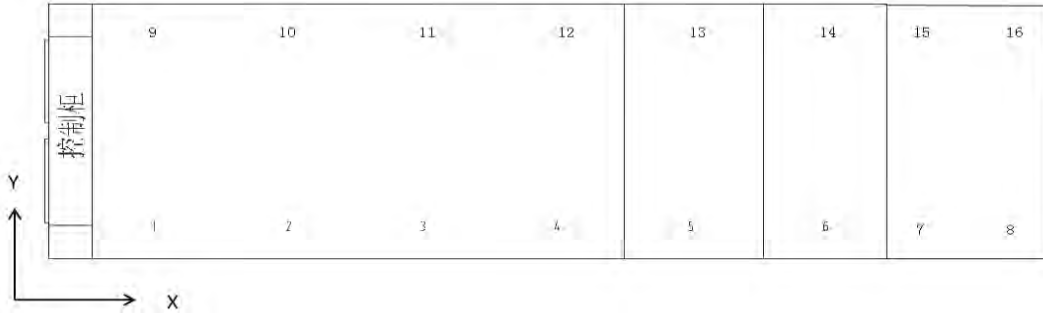

YVAA MODEL			DESCRIPTION	1	2	3	4	5	6	7	8	9	10	11	12	13	14	15	16
FRAME	CONDE	EVAP																	
037	3	F	Isolator X-Dimension / (inch)	10	81	145	205	284	427	—	—	10	81	145	205	284	427	—	—
			Isolator Y-Dimension / (inch)	1								87							
			Point Load (lbs)	743	1570	2455	2455	2816	964	—	—	751	1419	3135	3135	2998	964	—	—
041	3	H	Isolator X-Dimension / (inch)	10	81	145	205	284	427	—	—	10	81	145	205	284	427	—	—
			Isolator Y-Dimension / (inch)	1								87							
			Point Load (lbs)	797	1328	2447	2447	2457	964	—	—	813	1167	3043	3043	2580	964	—	—
044	3	G	Isolator X-Dimension / (inch)	10	81	145	205	284	427	483	539	10	81	145	205	284	427	483	539
			Isolator Y-Dimension / (inch)	1								87							
			Point Load (lbs)	415	2617	3160	3160	2285	976	451	436	396	2548	3152	3152	2388	976	451	436
048	3	G	Isolator X-Dimension / (inch)	10	81	145	205	284	427	505	562	10	81	145	205	284	427	505	562
			Isolator Y-Dimension / (inch)	1								87							
			Point Load (lbs)	686	2160	3224	3224	2240	1202	386	759	667	2092	3216	3216	2343	1202	386	759
052	3	J	Isolator X-Dimension / (inch)	10	81	145	205	284	427	505	562	10	81	145	205	284	427	505	562
			Isolator Y-Dimension / (inch)	1								87							
			Point Load (lbs)	794	2611	3112	3112	2916	1202	386	759	772	2550	3098	3098	3026	1202	386	759

NOTE: Weights shown for base unit; selected options may add weight to unit. Contact your nearest Johnson Controls Sales Office for weight data

TABLE 11- ISOLATOR LOCATIONS (SI)

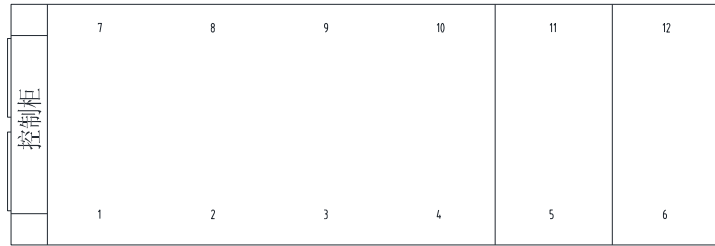

YVAA MODEL			DESCRIPTION	1	2	3	4	5	6	7	8	9	10	11	12
FRAME	COND	EVAP													
015	3	B	Isolator Y-Dimension / (mm)	263	1852	3662	4900	—	—	263	1852	3662	4900	—	—
			Isolator Y-Dimension / (mm)	32				—	2213				—	—	
			Point Load (kg)	477	974	974	292	—	—	444	960	960	354	—	—
016	5	B	Isolator Y-Dimension / (mm)	263	1943	3000	3984	5589	—	263	1943	3000	3984	5589	—
			Isolator Y-Dimension / (mm)	32				—	2213				—	—	
			Point Load (kg)	400	344	812	812	477	—	391	332	811	811	501	—
017	8	C	Isolator Y-Dimension / (mm)	263	2057	3779	4756	6368	—	263	2057	3779	4756	6368	—
			Isolator Y-Dimension / (mm)	32				—	2213				—	—	
			Point Load (kg)	333	1047	725	725	670	—	329	998	733	733	706	—
018	3	A	Isolator Y-Dimension / (mm)	264	1943	3152	4136	5323	—	264	1943	3152	4136	5323	—
			Isolator Y-Dimension / (mm)	32				—	2213				—	—	
			Point Load (kg)	322	753	493	493	753	—	319	750	492	492	784	—
019	5	A	Isolator Y-Dimension / (mm)	263	1943	2999	3984	5299	7136	263	1943	2999	3984	5299	7136
			Isolator Y-Dimension / (mm)	32				—	2213				—	—	
			Point Load (kg)	386	386	595	984	318	318	383	383	583	1010	325	325
019	8	B	Isolator Y-Dimension / (mm)	263	1943	2999	3984	5298	7823	263	1943	2999	3984	5298	7823
			Isolator Y-Dimension / (mm)	34				—	2215				—	—	
			Point Load (kg)	278	959	299	299	1108	275	269	966	295	295	1141	275
020	0	C	Isolator Y-Dimension / (mm)	263	1159	2707	3922	5501	—	263	1159	2707	3922	5501	—
			Isolator Y-Dimension / (mm)	32				—	2213				—	—	
			Point Load (kg)	410	440	891	880	590	—	378	437	887	874	634	—
021	3	A	Isolator Y-Dimension / (mm)	263	1943	2999	3984	5299	7136	263	1943	2999	3984	5299	7136
			Isolator Y-Dimension / (mm)	32				—	2213				—	—	
			Point Load (kg)	386	386	597	1002	322	322	383	383	584	1014	326	326
021	5	C	Isolator Y-Dimension / (mm)	263	2057	3779	4756	6368	—	263	2057	3779	4756	6368	—
			Isolator Y-Dimension / (mm)	32				—	2213				—	—	
			Point Load (kg)	299	941	773	773	770	—	296	903	776	776	806	—
021	8	C	Isolator Y-Dimension / (mm)	263	2057	3779	4756	5968	7653	263	2057	3779	4756	5968	7653
			Isolator Y-Dimension / (mm)	34				—	2215				—	—	
			Point Load (kg)	325	1237	256	256	1103	551	320	1202	259	259	1126	563
023	3	B	Isolator Y-Dimension / (mm)	263	1943	2999	3984	5298	7135	263	1943	2999	3984	5298	7135
			Isolator Y-Dimension / (mm)	32				—	2213				—	—	
			Point Load (kg)	430	430	646	1012	299	299	423	423	649	1019	304	304
024	5	C	Isolator Y-Dimension / (mm)	263	1943	3260	4391	5579	7654	263	1943	3260	4391	5579	7654
			Isolator Y-Dimension / (mm)	34				—	2215				—	—	
			Point Load (kg)	369	869	662	662	805	403	366	828	672	672	826	413
024	8	C	Isolator Y-Dimension / (mm)	263	2057	3638	4748	6232	8609	263	2057	3638	4748	6232	8609
			Isolator Y-Dimension / (mm)	34				—	2215				—	—	
			Point Load (kg)	300	813	921	921	493	493	300	746	951	951	501	501

TABLE 11 - ISOLATOR LOCATIONS (SI) (CONT'D)

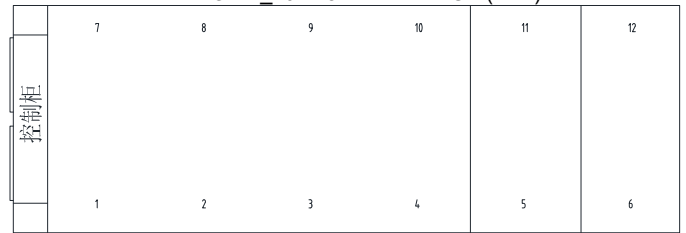

YVAA MODEL			DESCRIPTION	1	2	3	4	5	6	7	8	9	10	11	12	
FRAME	CONDE	EVAP														
026	3	B	Isolator Y-Dimension / (mm)	263	1943	2999	3984	5298	7823	263	1943	2999	3984	5298	7823	
			Isolator Y-Dimension / (mm)	34						2215						
			Point Load (kg)	315	961	313	313	1121	275	306	969	302	302	1144	275	
027	3	D	Isolator Y-Dimension / (mm)	260	2054	4081	5102	7651	—	260	2054	4081	5102	7651	—	
			Isolator Y-Dimension / (mm)	34						—	2215					
			Point Load (kg)	322	698	1260	969	630	—	309	622	1377	882	688	—	
027	5	E	Isolator Y-Dimension / (mm)	263	2057	4084	5105	7654	—	263	2057	4084	5105	7654	—	
			Isolator Y-Dimension / (mm)	34						—	2215					
			Point Load (kg)	313	744	1304	1036	652	—	300	669	1420	950	710	—	
027	8	E	Isolator Y-Dimension / (mm)	263	2057	4084	5105	7582	8609	263	2057	4084	5105	7582	8609	
			Isolator Y-Dimension / (mm)	34						2215						
			Point Load (kg)	295	803	1150	1150	412	412	270	784	1147	1147	436	436	
029	5	E	Isolator Y-Dimension / (mm)	260	2054	4092	5102	7509	8606	260	2054	4092	5102	7509	8606	
			Isolator Y-Dimension / (mm)	34						2215						
			Point Load (kg)	314	826	1149	1149	417	417	285	830	1189	1189	441	441	
030	3	C	Isolator Y-Dimension / (mm)	260	2054	3636	4745	6229	8606	260	2054	3636	4745	6229	8606	
			Isolator Y-Dimension / (mm)	34						2215						
			Point Load (kg)	321	818	939	939	492	492	321	756	1018	1018	496	496	
030	5	C	Isolator Y-Dimension / (mm)	260	2054	3660	4752	7044	9723	260	2054	3660	4752	7044	9723	
			Isolator Y-Dimension / (mm)	34						2215						
			Point Load (kg)	394	658	991	991	749	391	347	703	1016	1016	807	391	
030	8	E	Isolator Y-Dimension / (mm)	260	2054	4081	5102	7579	9723	260	2054	4081	5102	7579	9723	
			Isolator Y-Dimension / (mm)	34						2215						
			Point Load (kg)	363	908	970	970	843	391	358	893	1014	1014	879	391	
031	8	E	Isolator Y-Dimension / (mm)	260	2054	4081	5102	7579	10840	260	2054	4081	5102	7579	10840	
			Isolator Y-Dimension / (mm)	34						2215						
			Point Load (kg)	357	922	938	938	1003	459	352	907	981	981	1040	459	
032	3	E	Isolator Y-Dimension / (mm)	260	2054	4081	5102	7579	8606	260	2054	4081	5102	7579	8606	
			Isolator Y-Dimension / (mm)	34						2215						
			Point Load (kg)	318	801	1225	1225	417	417	287	812	1215	1215	437	437	
033	3	C	Isolator Y-Dimension / (mm)	260	2054	3634	4779	6229	9723	260	2054	3634	4779	6229	9723	
			Isolator Y-Dimension / (mm)	34						2215						
			Point Load (kg)	261	1329	404	404	1518	391	200	1441	321	321	1633	391	
034	3	E	Isolator Y-Dimension / (mm)	260	2054	4081	5102	7579	9723	260	2054	4081	5102	7579	9723	
			Isolator Y-Dimension / (mm)	34						2215						
			Point Load (kg)	363	905	1025	1025	866	391	358	892	1025	1025	885	391	
034	5	E	Isolator Y-Dimension / (mm)	260	2054	4081	5102	7579	10840	260	2054	4081	5102	7579	10840	
			Isolator Y-Dimension / (mm)	34						2215						
			Point Load (kg)	356	919	993	993	1027	460	351	905	993	993	1046	460	

5

TABLE 11 - ISOLATOR LOCATIONS (SI) (CONT'D)

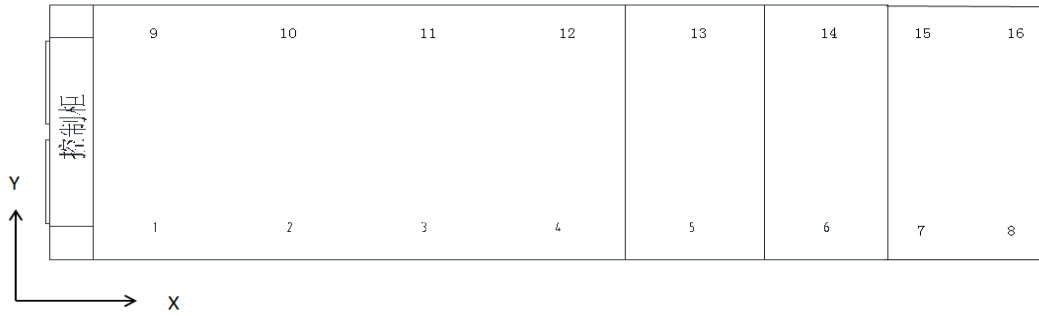

YVAA MODEL			DESCRIPTION	1	2	3	4	5	6	7	8	9	10	11	12	13	14	15	16
FRAME	CONDE	EVAP		1	2	3	4	5	6	7	8	9	10	11	12	13	14	15	16
037	3	F	Isolator X-Dimension / (mm)	260	2046	3677	5216	7215	10839	—	—	260	2046	3677	5216	7215	10839	—	—
			Isolator Y-Dimension / (mm)	34								2204							
			Point Load (Kg)	337	712	1113	1113	1277	437	—	—	341	644	1422	1422	1360	437	—	—
041	3	H	Isolator X-Dimension / (mm)	260	2046	3677	5216	7215	10839	—	—	260	2046	3677	5216	7215	10839	—	—
			Isolator Y-Dimension / (mm)	34								2204							
			Point Load (Kg)	361	602	1110	1110	1114	437	—	—	369	529	1380	1380	1170	437	—	—
044	3	G	Isolator X-Dimension / (mm)	262	2057	3907	5220	7219	10843	12271	13691	262	2057	3907	5220	7219	10843	12271	13691
			Isolator Y-Dimension / (mm)	34								2204							
			Point Load (Kg)	188	1187	1433	1433	1036	443	205	198	180	1156	1430	1430	1083	443	205	198
048	3	G	Isolator X-Dimension / (mm)	262	2057	3907	5220	7219	10843	12819	14265	262	2057	3907	5220	7219	10843	12819	14265
			Isolator Y-Dimension / (mm)	34								2204							
			Point Load (Kg)	311	980	1462	1462	1016	545	175	344	303	949	1459	1459	1063	545	175	344
052	3	J	Isolator X-Dimension / (mm)	262	2057	3907	5220	7219	10843	12819	14265	262	2057	3907	5220	7219	10843	12819	14265
			Isolator Y-Dimension / (mm)	34								2204							
			Point Load (Kg)	360	1184	1411	1411	1323	545	175	344	350	1157	1405	1405	1373	545	175	344

NOTE: Weights shown for base unit; selected options may add weight to unit. Contact your nearest Johnson Controls Sales Office for weight data

ELASTOMETRIC ISOLATOR INSTALLATION

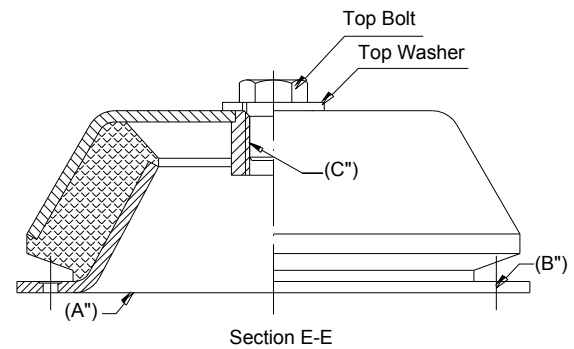
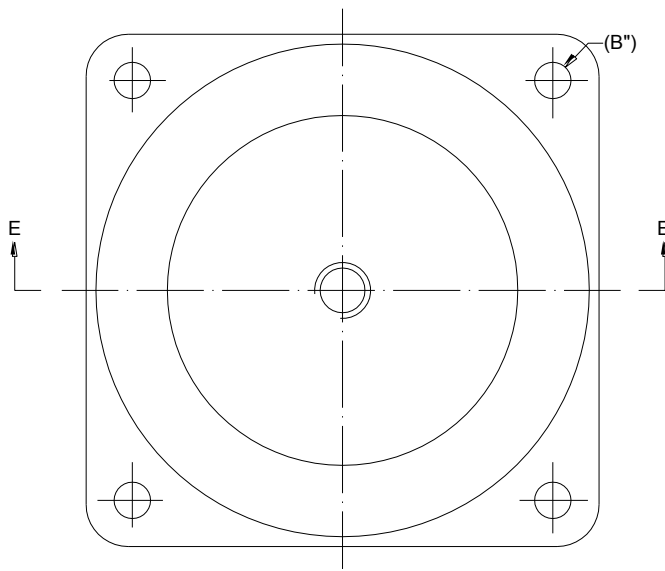

1. Read the following instructions before beginning installation.
2. Isolators are shipped fully assembled and are to be positioned in accordance with the submittal drawings or as otherwise recommended.
3. Set isolators on floor, housekeeping pad or subbase, ensuring that all isolators' centerlines match the equipment mounting holes. It is recommended that the isolator base (A) be installed on a level surface. Shim or grout as required, leveling all isolator bases to the same elevation (0.03125" (0.78 mm) maximum difference can be tolerated).
4. Bolt or anchor all isolators to supporting structure utilizing base thru holes (B).
5. Remove top bolt and top washer. Place equipment on top of isolators so that mounting holes in equipment or base line up with threaded hole (C).
6. Reinstall top bolt and washer and tighten down.

ELASTOMETRIC ISOLATOR SPECIFICATIONS

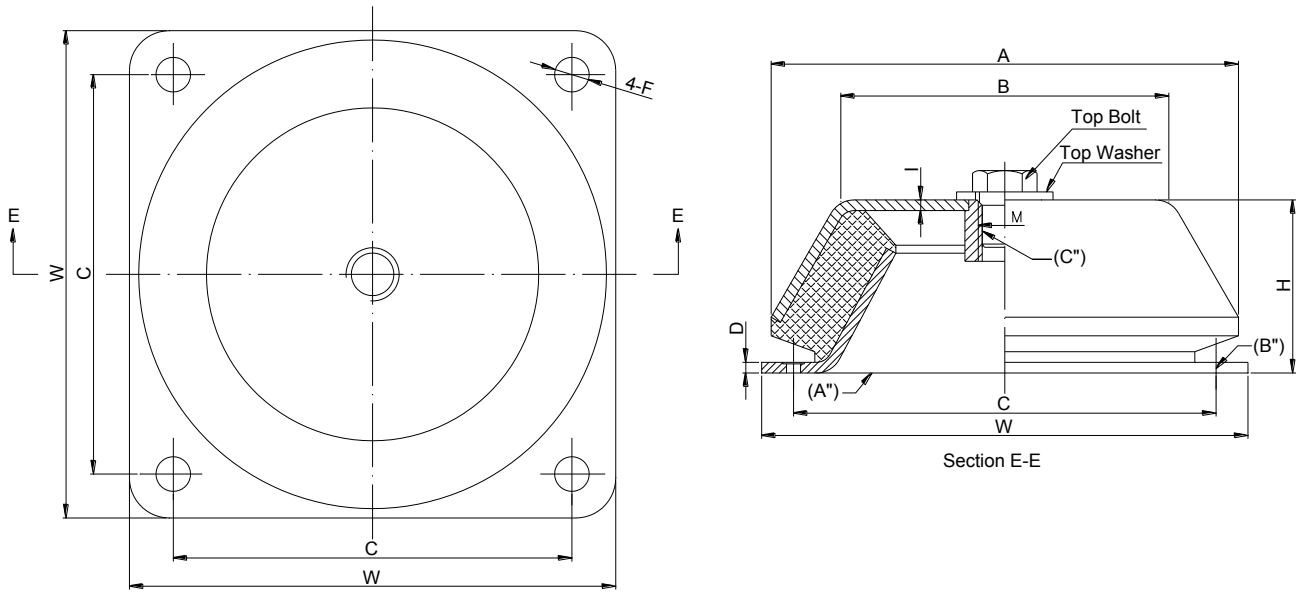

MOUNT TYPE	DIMENSION DATA (mm)							
	A	B	C	W	H	D	M	F
JG 1	Φ 146	Φ 95	125	150	55	3	M16	Φ 13
JG 2	Φ 176	Φ 125	150	183	65	4	M16	Φ 13

MODEL NUMBER	RATED CAPACITY (FOR UNITS WITH ALL LOAD POINTS LESS THAN 1984 LBS (900 KG))		
	Weight Range		PART NUMBER
	(LBS.)	(KG)	
JG 1-1	331 thru 661	150 thru 300	028G00031A035(716487)
JG 1-2	662 thru 1213	301 thru 550	028G00031A036(716488)
JG 1-3	1214 thru 1984	551 thru 900	028G00031A037(716489)

MODEL NUMBER	RATED CAPACITY (FOR UNITS WITH ALL LOAD POINTS LESS THAN 4409 LBS (2000 KG))		
	Weight Range		PART NUMBER
	(LBS.)	(KG)	
JG 2-1	882 thru 1984	400 thru 900	028G00031A038(716490)
JG 2-2	1985 thru 3527	901 thru 1600	028G00031A039(716491)
JG 2-3	3528 thru 4409	1601 thru 2000	028G00031A040(716492)

Notes:

1. All dimensions are in millimeter.
2. Use either all JG 1's or all JG 2's at all locations on a unit
3. Installation requires bolting or anchoring mount to support structure with a 4 x 0.5122"(4 x 13.0mm) diameter bolts or 2 x 0.5"(2 x 12.7mm) diameter concrete anchors

1" SPRING ISOLATOR INSTALLATION

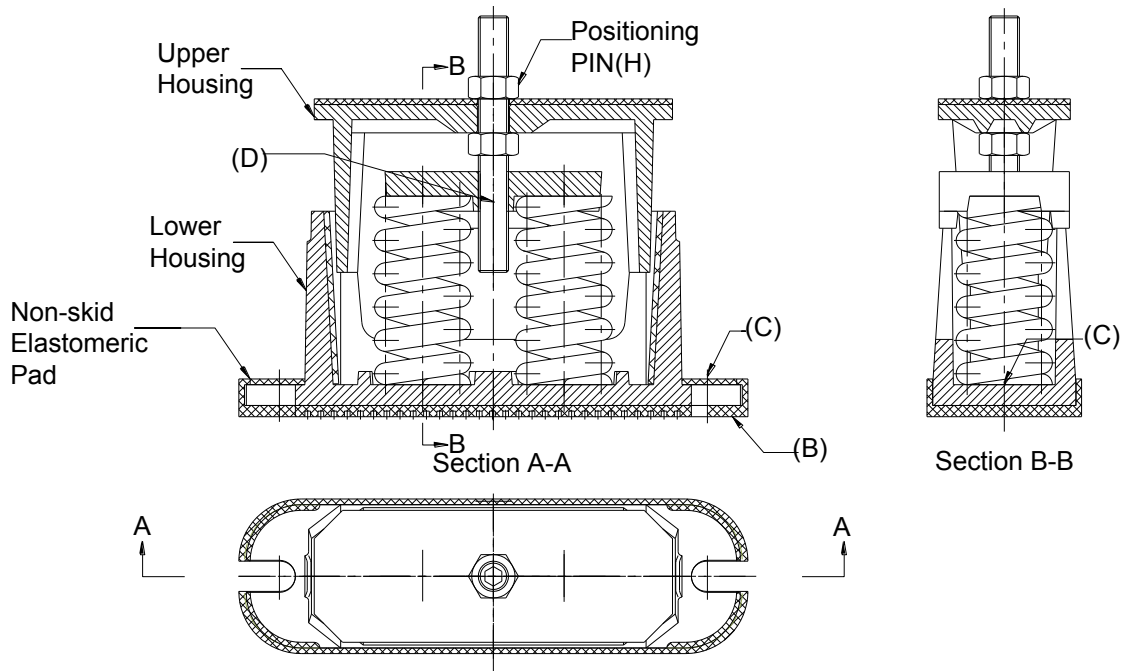

1. Read the following instructions before beginning installation.
2. Isolators are shipped fully assembled and are to be positioned in accordance with the submittal drawings or as otherwise recommended.
3. Set isolators on floor, housekeeping pad or sub-base, ensuring that all isolator's centerlines match the equipment mounting holes. It is recommended that the isolator base (B) be installed on a level surface. Shim or grout as required, leveling all isolator bases to the same elevation (0.25" (6.3mm) maximum difference can be tolerated).
4. Bolt or anchor all isolators to supporting structure utilizing base slotted holes (C).
5. Place equipment on top of isolators making sure that mounting holes of the equipment line up with isolator positioning pin (H).
6. Equipment or machine is at its full operating weight.
7. Adjust each isolator in sequence by turning spring adjusting bolt (D) one full counterclockwise turn at a time. Repeat this procedure on all isolators, one at a time.
8. Continue adjusting each isolator until same clearance is achieved between the lower housing and upper housing for all isolators.
9. Fine adjust isolators to level equipment.

1" SPRING ISOLATOR

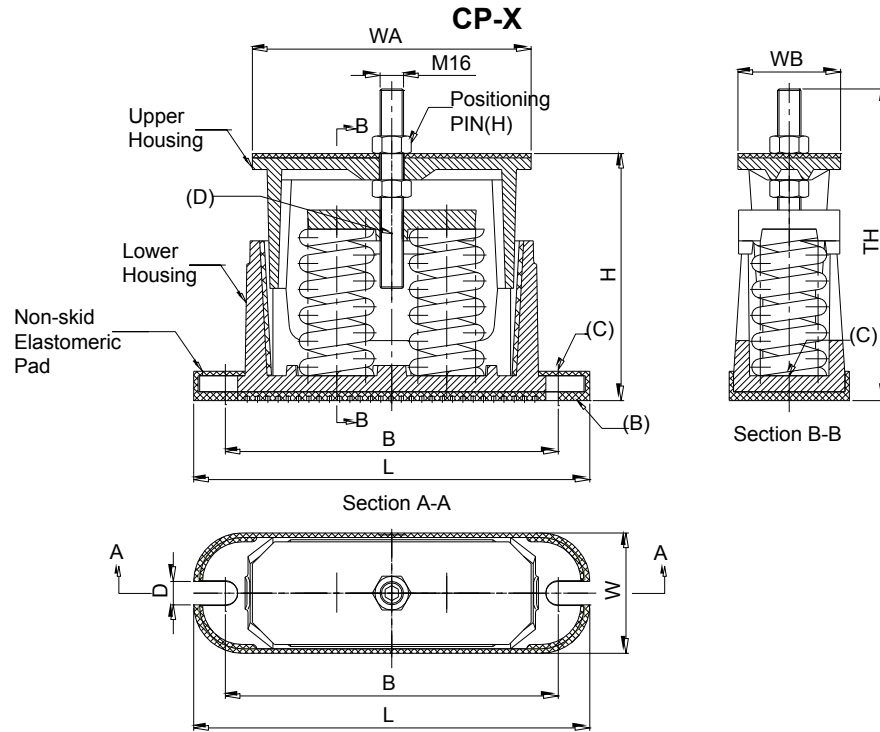

MOUNT TYPE	DIMENSION DATA (mm)							
	WA	WB	H	TH	B	L	D	W
CP-2	190	70	168	211	228	270	16	80
CP-4	193	130	160	202	228	270	16	142

MODEL NUMBER	Spring Number	RATED CAPACITY (FOR UNITS WITH ALL LOAD POINTS LESS THAN 1808 LBS (820 KG))		
		Weight Range		PART NUMBER
		(LBS.)	(KG)	
CP-2-200	2	Up thru 441	Up thru 200	029G23000A028(717762)
CP-2-300	2	442 thru 661	201 thru 300	029G23000A029(717763)
CP-2-400	2	662 thru 882	301 thru 400	029G23000A018(716477)
CP-2-550	2	883 thru 1213	401 thru 550	029G23000A019(716478)
CP-2-680	2	1214 thru 1499	551 thru 680	029G23000A030(717764)
CP-2-820	2	1500 thru 1808	681 thru 820	029G23000A020(716479)

MODEL NUMBER	Spring Number	RATED CAPACITY (FOR UNITS WITH ALL LOAD POINTS LESS THAN 3594 LBS (1630 KG))		
		Weight Range		PART NUMBER
		(LBS.)	(KG)	
CP-4-400	4	Up thru 882	Up thru 400	029G23000A021(716480)
CP-4-550	4	883 thru 1213	401 thru 550	029G23000A022(716481)
CP-4-680	4	1214 thru 1499	551 thru 680	029G23000A023(716482)
CP-4-820	4	1500 thru 1808	681 thru 820	029G23000A024(716483)
CP-4-1100	4	1809 thru 2425	821 thru 1100	029G23000A025(716484)
CP-4-1360	4	2426 thru 2998	1101 thru 1360	029G23000A026(716485)
CP-4-1630	4	2999 thru 3594	1361 thru 1630	029G23000A027(716486)

Notes:

1. All dimensions are in millimeter.
2. Use either all CP-1's or all CP-2's at all locations on a unit.
3. Installation requires bolting or anchoring mount to support structure with a 2 x 0.625"(2x16mm) diameter bolts or 2 x 0.5"(2x12.7mm) diameter concrete anchors.

TWO INCH DEFLECTION ISOLATOR INSTALLATION AND ADJUSTMENT

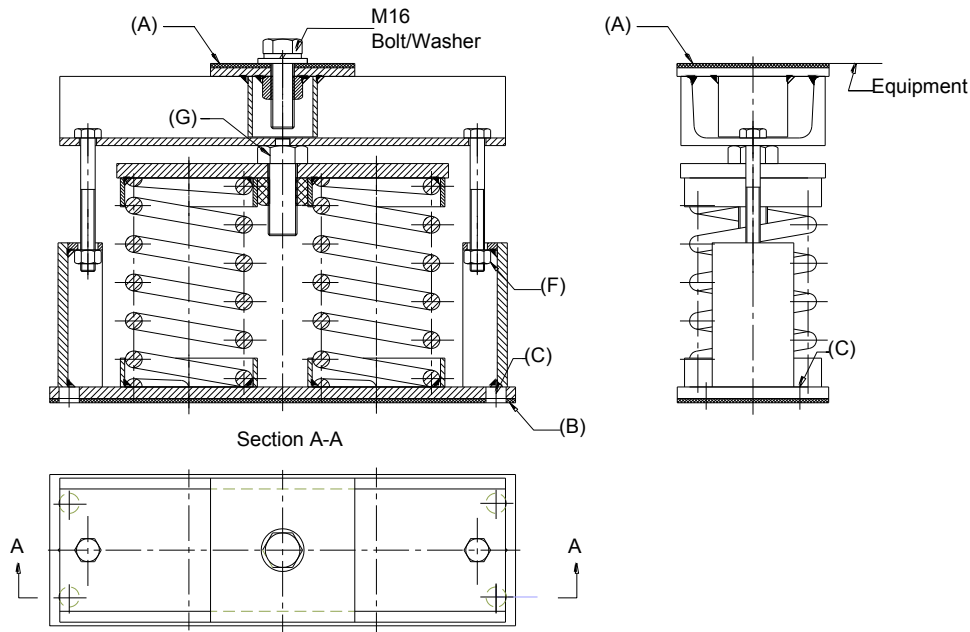

1. Read the following instructions before beginning installation.
2. Isolators are shipped fully assembled and are to be positioned in accordance with the submittal drawings or as otherwise recommended.
3. Set isolators on floor, housekeeping pad, or sub-base, ensuring that all isolator centerlines match the equipment mounting holes. It is recommended that the isolator base plates (B) be installed on a level surface. Shim or grout as required, leveling all isolator base plates to the same elevation (0.25"(6.35mm) maximum difference can be tolerated).
4. Bolt or anchor all isolators to supporting structure utilizing base plate thru holes (C) or weld base plate to supporting structure with 0.375"(9.5mm) fillet weld 2"(50.8mm) long @ 4"(101.6mm) on centre around entire base plate or as engineered for specific load and or field conditions.
5. The adjustment process can only begin after the equipment or machine is at its full operating weight
6. Bolt or anchor all isolators to supporting structure utilizing base slotted holes (C).
7. Place equipment on top of isolators making sure that mounting holes of the equipment line up with isolator M16 bolt.
8. Adjust each isolator in sequence by turning spring adjusting nuts (G) one full clockwise turn at a time. Repeat this procedure on all isolators, one at a time. Continue adjusting each isolator until same clearance is achieved between the lower housing and top plate. Check the limit stop lock nuts (F) periodically to ensure that clearance between the washer and grommet is maintained.
9. Fine adjust isolators to level equipment.
10. Adjust all limit stop lock nuts (F) per isolator, maintaining 0.25"(6.3mm) to 0.375"(9.5mm) gap. The limit stop nuts must be kept at this gap to ensure uniform bolt loading during uplift (as the case when equipment is drained)

TWO INCH DEFLECTION, RESTRAINED SPRING ISOLATOR ZGT-F2

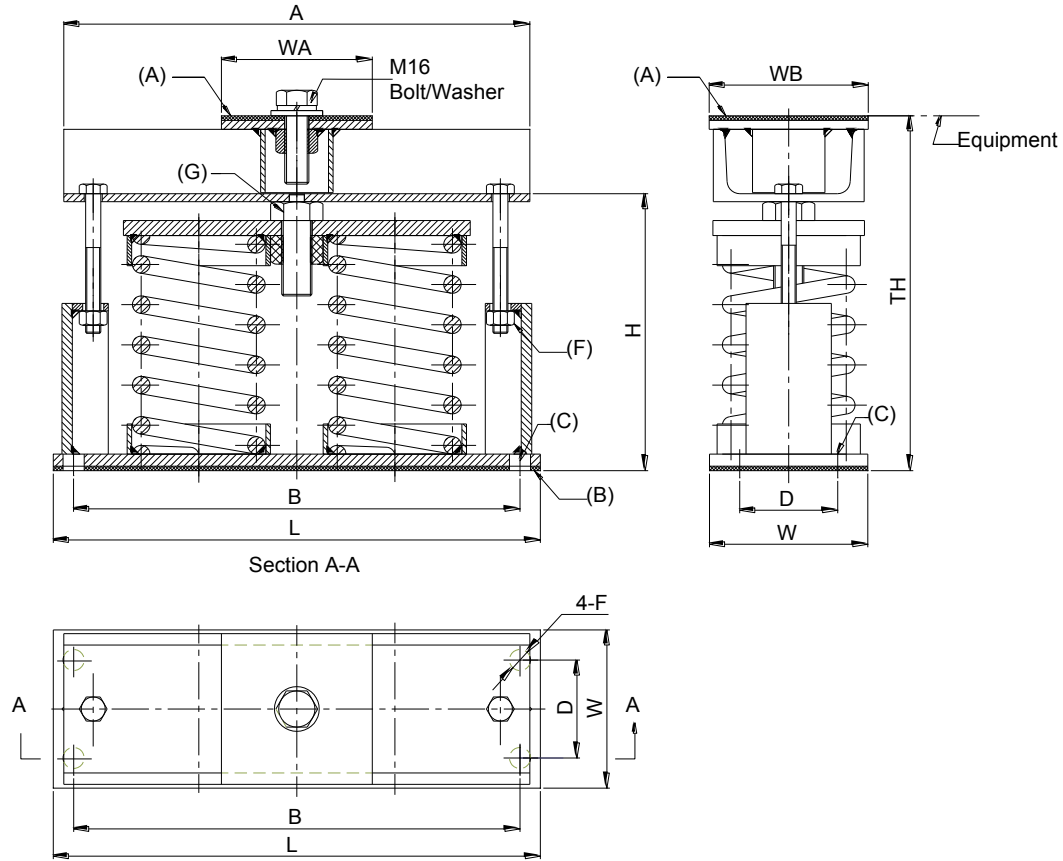

MOUNT TYPE	DIMENSION DATA (mm)									
	A	WA	WB	W	H	TH	B	L	D	F
ZGT-F2	290	110	110	110	150	200	283	310	60	Φ 16

MODEL NUMBER	RATED CAPACITY (FOR UNITS WITH ALL LOAD POINTS LESS THAN 3527 LBS (1600 KG))		
	Weight Range		PART NUMBER
	(LBS.)	(KG)	
ZGT-F2-200	0 thru 441	0 thru 200	029G23000A031(717765)
ZGT-F2-300	442 thru 661	201 thru 300	029G23000A032(717766)
ZGT-F2-350	662 thru 772	301 thru 350	029G23000A033(717767)
ZGT-F2-500	773 thru 1102	351 thru 500	029G23000A034(717768)
ZGT-F2-650	1103 thru 1433	501 thru 650	029G23000A035(717769)
ZGT-F2-1000	1434 thru 2205	651 thru 1000	029G23000A036(717770)
ZGT-F2-1200	2206 thru 2646	1001 thru 1200	029G23000A037(717771)
ZGT-F2-1600	2647 thru 3527	1201 thru 1600	029G23000A038(717772)

Notes:

1. All dimensions are in millimeter.
2. Equipment must be bolted or welded to the top plate to meet allowable seismic ratings.
3. Consult JCI for concrete installation.

SECTION 6 - COMMISSIONING

PREPARATION

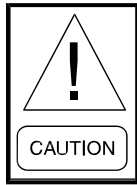

Commissioning of this unit should only be carried out by Johnson Controls Authorized personnel.

Commissioning personnel should be thoroughly familiar with the information contained in this document before starting the unit.

The following basic checks should be made with the customer power to the unit switched OFF.



Proper electrical lock out and tag out procedures must be followed.

For YVAA0373/0413/0443/0483/0523 unit, There are independent circuit breaker/ disconnect Switch in Each circuit of Sys1 and Sys2. Make sure power on Sys2 first and then Sys1 by closing corresponding circuit breaker/ disconnect Switch. Should the power on sequence be reversed, Unit will report "Sys 2- single phase input Volts" fault and the unit could not start

Inspection

Inspect unit for installation damage. If found, take action and/or repair as appropriate.

Refrigerant Charge

Packaged units are normally shipped as standard with a full refrigerant operating charge. Check that refrigerant pressure is present in both systems and that no leaks are apparent. If no pressure is present, a leak test must be undertaken, the leak(s) located and repaired.

Do not evacuate or liquid charge with static water in the cooler. Turn the pump on. Take care to liquid charge slowly to avoid excessive thermal stress at the charging point and to assure the refrigerant temperature in the evaporator does not go below the freezing point with liquid refrigerant in the evaporator. Once the vacuum is broken, charge into the evaporator or flash tank with the Condenser Drain Valve (Flash Tank Feed) open and the chilled liquid pump ON to the full operating charge, as detailed in *SECTION 5 - TECHNICAL DATA on Page 37*.

Correct System Refrigerant Charge

The charge on a system should always be checked when operating for several minutes at full speed with the system stable. Stable conditions are defined as operation without fan cycling, economizer cycling, VI solenoid cycling, or any other system transient conditions. Ideal refrigerant charge will be reached when the refrigerant level in the evaporator is near the middle of the evaporator sight glass.

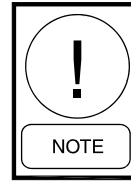

Refrigerant should not be added or removed unless the level is at the bottom or the top of the glass. It is not necessary to weigh charge unless the entire charge has been lost. The ease of charging is possible since the microchannel coils hold only a small amount of refrigerant charge. A charging valve is located between the fixed orifice and the evaporator for adjusting charge. Charge should be added as liquid with the pump ON and liquid flowing through the evaporator.

Service and Oil Line Valves

Open each compressor oil, economizer, and discharge ball or service valves. If valves are of the back-seat type, open them fully (counterclockwise) then close one turn of the stem to ensure operating pressure is fed to pressure transducers.

Compressor Oil

To add oil to a circuit - connect a YORK hand oil pump (Part No. 470-10654-000) to the 1/4" (6.35 mm) oil charging valve on the oil separator piping with a length of clean hose or copper line, but do not tighten the flare nut. Using clean oil of the correct type ("L" oil), pump oil until all air has been purged from the hose then tighten the nut. Stroke the oil pump to add oil to the oil system. While the compressor is running at full speed, the oil level should be above middle of the lower sight glass of the oil separator.

Avoid levels in either oil separator that are above the middle of the top sight glass. This may cause excessive oil carryover in the system. High oil concentration in the system may cause nuisance trips resulting from incorrect readings on the level sensor and temperature sensors. Temperature sensor errors may result in poor liquid control which will result in liquid overfeed and subsequently damage the compressor. High oil carryover may also cause liquid to be returned to the compressor, which can damage the compressor.

and could cause damage.

Fans

Check that all fans are free to rotate and are not damaged. Ensure blades are at the same height when rotated. Ensure fan guards are securely fixed.

Isolation / Protection

Verify all sources of electrical supply to the unit are taken from a single point of isolation. Check that the maximum recommended fuse sizes given in *SECTION 5 - TECHNICAL DATA on Page 37* has not been exceeded.

Control Panel

Check the panel to see that it is free of foreign materials (wire, metal chips, etc.) and clean out if required.

Power Connections

Check that the customer power cables are connected correctly to the terminal blocks or optional circuit breaker. Ensure that connections of power cables within the panels to the circuit breaker or terminal blocks are tight.

Grounding

Verify that the unit's protective ground terminal(s) are properly connected to a suitable grounding point. Ensure that all unit internal ground connections are tight.

Water System

Verify the chilled liquid system has been installed correctly, and has been commissioned with the correct direction of water flow through the cooler. The inlet should be at the bottom connection on a two pass cooler. Purge air from the top of the cooler using the plugged air vent mounted on the top of the cooler body.

Flow rates and pressure drops must be within the limits given in *SECTION 5 - TECHNICAL DATA on Page 37*. Operation outside of these limits is undesirable

If mains power must be switched OFF for extended maintenance or an extended shutdown period, precautions must be taken. If there is a possibility of liquid freezing due to low ambient temperatures, the cooler should be drained or power should be applied to the chiller. This will allow the cooler heater to protect the cooler from freezing down to -17.8°C (0°F). Before placing the unit back in service, valves should be opened and power must be switched on (if power is removed for more than 8 hours) for at least 8 hours (24 hours if ambient temperature is below 30°C [86°F]) before the unit is restarted.

Flow Switch

Verify a chilled water flow switch is correctly fitted in the customer's piping on the cooler outlet, and wired into the control panel correctly using shielded cable.

There should be a straight run of at least five pipe diameters on either side of the flow switch. The flow switch should be connected to Terminals 2 and 13 in the panel.

Temperature Sensor(s)

Ensure the leaving liquid temperature sensor is coated with heat conductive compound (Part No. 013-00890-000) and is inserted to the bottom of the water outlet sensor well in the cooler. This sensor also provides some freeze protection and must always be fully inserted in the water outlet sensor well.

Programmed Options

Verify that the options factory-programmed into the Micro Panel are in accordance with the customer's order requirements by pressing the OPTIONS key on the keypad and reading the settings from the display.

Programmed Settings

Ensure the system cutout and operational settings are in accordance with the operating requirements by pressing the PROGRAM key.

Date and Time

Program the date and time by first ensuring that the CLK jumper JP2 on the Chiller Control Board is in the ON position. Then press the DATE/TIME key and set the date and time (see *SECTION 8 - MICROPANEL Date/Time and Schedule Keys on Page 98*).

Start/Stop Schedule

Program the daily and holiday start/stop by pressing the SCHEDULE key (see *SECTION 8 - MICROPANEL Date/Time and Schedule Keys on Page 98*).

Setpoint and Remote Offset

Set the required leaving chilled liquid temperature setpoint and Control Range under the SETPOINTS key. The chilled liquid temperature control settings need to be set according to the required operating conditions.

If remote temperature reset (offset) is to be used, the maximum reset required must be programmed by pressing the SETPOINTS key (see *SECTION 8 - MICROPANEL Setpoints Key on Page 90*).

FIRST TIME START

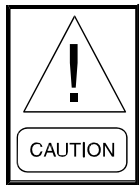

During the commissioning period there should be sufficient heat load to run the unit under stable full load operation to enable the unit controls, and system operation to be set up correctly, and a commissioning log taken.

Interlocks

Verify that liquid is flowing through the cooler and that heat load is present. Ensure that any remote run interlocks are in the run position and that the Daily Schedule requires the unit to run or is overridden.

Unit Switch

Place the UNIT switch on the keypad to the ON position.

Startup

Press the SYSTEM SWITCHES key and place the system switch for System 1 to the ON position. There may be a few seconds delay before the first compressor starts because of the anti-recycle timer). Be ready when each compressor starts, to switch the UNIT switch OFF immediately, if any unusual noises or other adverse conditions develop.

When a compressor is running, the controller monitors oil pressure, motor current, and various other system parameters such as discharge pressure, chilled liquid temperature, etc. Should any problems occur; the control system will immediately take appropriate action and display the nature of the fault.

Oil Pressure

When a compressor starts, press the relevant “System Pressures” key and verify that oil differential pressure (oil pressure-suction pressure) develops immediately. If oil pressure does not develop, the automatic controls will shut down the compressor. Under no circumstances should a restart attempt be made on a compressor, which does not develop oil pressure immediately. Switch the UNIT switch to the OFF position.

Loading

Once the unit has been started, all operations are fully automatic. After an initial period at minimum capacity, the control system will adjust the unit load depending on the chilled liquid temperature and rate of temperature change. If a high heat load is present, the controller will increase the speed of the compressor(s).

Condenser and Fan Rotation

Once a compressor is running, discharge pressure rises as refrigerant is pumped into the air-cooled condenser coils. This pressure is controlled by stages of fans to ensure maximum unit efficiency while maintaining sufficient pressure for correct operation of the condensers and the lubrication system.

As discharge pressure rises, the condenser fans operate in stages or ramp up in speed to control the pressure. Verify that the fans operate in the correct direction of rotation and operation is correct for the type of unit.

System Charge

Check system charge at steady full compressor load only. It is important that all fans are running for the system. The refrigerant level in the evaporator should be about in the middle of the sight glass. Unless levels are at the bottom or the top of the sight glass, they should not cause concern or require adding or removing charge.

General Operation

After completion of the above checks for System 1, switch OFF the SYS 1 switch on the keypad and repeat the process for each subsequent system. When all run correctly, stop the unit, switch all applicable switches to the „ON“ position and restart the unit.

Assure all checks are completed in the Equipment Pre - Startup and Startup Checklist. The chiller is then ready to be placed into operation.

SECTION 7 - OPERATION

OPERATING CONTROLS

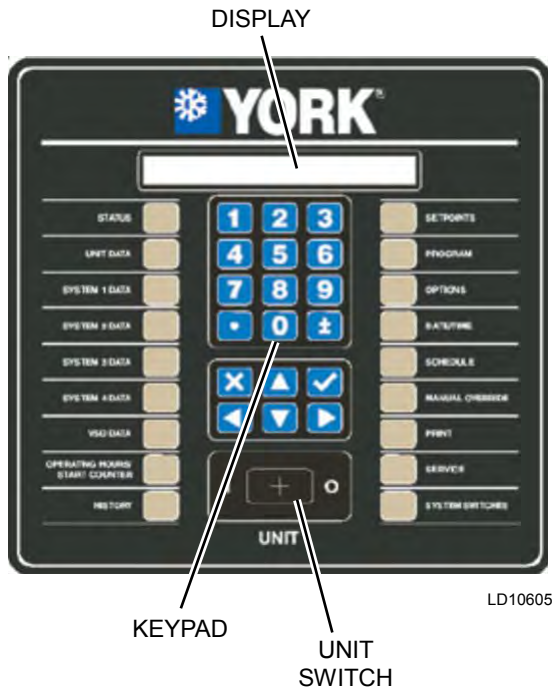

FIGURE 16- KEYBOARD AND DISPLAY

Unit Switch

A double pole single throw ON/OFF rocker switch on the front of the control panel is used to turn the entire chiller ON and OFF. When the switch is placed in the OFF position, the entire unit shuts down immediately and all systems will be disabled. One pole of the UNIT switch contacts is wired to the Run Signal input and the Chiller Control Board “UNIT switch X” digital input (X equals System 1 or 2). Separate System Fuses are also wired in series with each set of UNIT switch contacts. If either fuse is pulled or blown, only the system with the good fuse (Input is high) will run. When both inputs are high, the entire chiller will be enabled to run. When both inputs are low, the chiller will be disabled as a UNIT switch OFF Shutdown.

Keypad

An operator keypad allows complete control of the system from a central location. The keypad offers a multitude of command keys on the left and right side of the keypad to access displays, program setpoints, history data, and initiate system commands. Most keys have multiple displays that can be accessed by repetitively pressing the key or by pressing the ▲, ▼, ◀, and ▶ (ARROW) keys. The keypad utilizes an overlay to convert the keypad to various languages.

The keypad also contains keys in the center section for data entry in the various program modes. These keys are listed below:

- 0-9 Keys NUMERIC KEYPAD
- PERIOD/DECIMAL
- +/- PLUS/MINUS
- ✓ ENTER
- ✕ CANCEL
- ▲ UP ARROW
- ▼ DOWN ARROW
- ◀ LEFT ARROW
- ▶ RIGHT ARROW

The numeric keys allow keying numeric values into memory.

The • (PERIOD/DECIMAL) key allows keying a decimal point into numeric values.

The +/- (PLUS/MINUS) key allows making numeric values negative.

The ✓ (ENTER) key stores program changes into memory.

The X (CANCEL) key is used to cancel the data entry operation and returns the programmed value to the original value, before any programming changes were made, when an error is made.

The ▲ (UP ARROW) and ▼ (DOWN ARROW) keys allow scrolling backward (▲) and forward (▼) through items to be programmed under keys such as the PROGRAM or OPTIONS key.

The ▲ (UP ARROW) and ▼ (DOWN ARROW) keys also allow scrolling forward (▼) or backwards (▲) through data display keys that have multiple displays under keys such as UNIT DATA, SYSTEM DATA, HISTORY, PROGRAM, OPTIONS, etc. The arrow keys can be used instead of repeatedly pressing the data key to see the multiple displays under a key. Once the ▲ ▼ (ARROW) keys are pressed and used for scrolling, pressing the original data key will return to the first display message displayed under the data (UNIT DATA, SYSTEM DATA, etc.) keys.

The ◀ ▶ (LEFT and RIGHT ARROW) keys allow scrolling between non-numeric program choices under the OPTION, DATE/TIME, and SCHEDULE keys.

The ◀ (LEFT ARROW) key allows programming the default value when programming numeric values. For changing numeric values, the ▶ (RIGHT ARROW) key has no function.

The ◀ ▶ (ARROW) keys also allow scrolling sideways between the same displays on different systems. For example, pressing the ▶ (RIGHT ARROW) key while viewing the system #1 suction pressure moves the display to system #2 suction pressure.

Pressing the ◀ (LEFT ARROW) key moves the opposite direction. The arrow keys also allow fast scrolling through data under keys such as HISTORY by enabling the operator to move between subgroups of data such as Unit, System, and VSD data.

Keypad Data Entry Mode

For numeric programmable items, the data entry mode is entered by pressing any of the number keys, the decimal point key, or the +/- key. When the data entry mode is entered, the data from the key press will be entered and the cursor will appear under the position where the data is being entered.

For non-numeric programmable items, data entry mode is entered by pressing the ◀ or ▶ (ARROW) keys. When the data entry mode is entered, the cursor will appear under the first position of the non-numeric string. The programmable choice may be changed by pressing the ◀ or ▶ (ARROW) keys.

To exit the data entry mode and store the programmed value, the ✓ (ENTER) key must be pressed. When the ✓ (ENTER) key is pressed, the cursor will disappear.

The data entry mode may also be exited by pressing the X (CANCEL) key. The programmed data will be returned to its original value when the X (CANCEL) key is pressed.

When the data entry mode is exited, the cursor will disappear. If any other key is pressed while in the Data Entry Mode, the following display will appear for 2 seconds indicating the user must choose between accepting or canceling the change:

```
XXXXXXXXXX PRESS ✓ TO ACCEPT VALUE OR
X TO CANCEL DATA ENTRY
```

If the ✓ (ENTER) key was pressed from the data entry mode and the numeric value entered was out of range, the following message will appear for 2 seconds followed by the original data display.

```
XXXXXXXXXXXX OUT OF RANGE TRY AGAIN!
XXXXXXXXXXXXXXXXXXXXXXXXXXXXXXXXXXXXXXXXXXXX
```

Display

The 80 character (2 lines of 40 characters per line) display is a Liquid Crystal Display (LCD) used for displaying unit parameters, system parameters, and operator messages. The display has an LED backlight background for night viewing and is viewable in direct sunlight.

Anti-recycle Timer

On power-up of the control panel, the anti-recycle timer for each system will be set to 120 seconds and must time out before a compressor is allowed to start.

Whenever a system starts, the anti-recycle timer for all systems will be set to 120 seconds and will count down from the time the motor starts. The timer must time out before another compressor is allowed to start.

Whenever a system shuts down, the anti-recycle timer for that system will be set to 120 seconds. The timer must time out before the system is allowed to restart.

Evaporator Pump Control

The evaporator pump dry contacts are energized when any of the following conditions are true:

- If a Low Leaving Chilled Liquid Fault occurs.
- Whenever a compressor is running.
- The Daily Schedule is ON and the UNIT switch is ON.

Even if one of above is true, the pump will not run if the panel has been powered up for less than 30 seconds or if the pump has run in the last 30 seconds to prevent pump motor overheating.

Evaporator Heater Control

The evaporator heater is controlled by ambient air temperature. If no systems are running and the ambient temperature drops below 4.4 °C (40°F), the heater is turned ON. If no systems are running and the temperature rises above 7.2 °C (45°F) the heater is turned OFF. Whenever a system is running, the

evaporator heater is turned OFF. Both evaporator heater outputs will always be turned ON and OFF together. An under voltage condition will keep the heater OFF until full voltage is restored to the system. The heater will protect the evaporator from freeze-up down to -29°C (-20°F).

Compressor Heater Control

Each compressor has its own heater. The purpose of the heater is to assure refrigerant does not condense in the compressor. There is no oil sump, but refrigerant could possibly condense in the rotors or the motor housing. The heater will be OFF whenever the respective compressor is running. As soon as the compressor shuts OFF, the heater will turn ON as long as all motor temperature sensors in the compressor read less than 70°C (158°F). The heater will turn OFF, if any internal compressor motor temperature sensor reads more than 71.1°C (160°F).

Alarms

Each system has its own alarm. The Alarm output is ON (dry contact closed) when no fault condition is present and OFF (dry contact open) to indicate an alarm situation. The Alarm will be activated (contacts open), if any of the following are true.

- A System is faulted or inhibited from starting for more than 5 seconds.
- The Unit is faulted or inhibited from starting for more than 5 seconds.
- A System is locked out.
- The Unit is locked out.
- Power is removed from the chiller.

Chiller Run Contact

The Chiller Run dry contact is closed whenever any system is running. It is open when all systems are shut OFF.

Flow Switch Control

A chilled liquid flow switch of suitable type MUST be connected between Terminals 2 and 13 of 1TB to provide protection against loss of liquid flow, which will cause evaporator freeze-up if the chiller is permitted to run.

Remote Run / Stop

A Remote Run/Stop input is available for each system.

BASIC OPERATING SEQUENCE

Start Sequence and Loading

To initiate the start sequence of the chiller, the following conditions must be satisfied before the precharge of the DC Bus will take place:

- UNIT SWITCH must be ON.
- At least one System Switch is ON
- Run permissive inputs (Remote Cycling Contacts) must be closed.
- No unit faults exist.
- No unit start inhibits exist.
- At least one system not faulted or inhibited.
- The Daily Schedule is calling for the chiller to run.
- The Flow Switch is closed.
- Leaving Chilled Liquid Setpoint is above the Setpoint plus CR (Setpoint High Limit).

Once the precharge takes place, if the anti-recycle timer is timed out the chiller control system on the Chiller Control Board will select the number of compressors to start and begin operation of the compressors. The compressor(s) speed will be ramped to the minimum start frequency and increase speed as needed in an effort to regulate the leaving chilled liquid temperature to meet the desired Setpoint. Unit Warnings

UNIT WARNING

Unit Warning Operation

Unit warnings are caused when a condition is present requiring operator intervention to restart the unit. All setpoints, program values, and options should be checked before operating the unit. Warnings are not logged to the history buffer. If a unit warning is in effect, the message will be displayed to the operator when the STATUS key is pressed.

Low battery Warning

The LOW BATTERY WARNING can only occur at unit power-up. On micropanel power-up, the RTC battery is checked to see if it is still operational. If it is, normal unit operation is allowed. If the battery voltage is determined to be low, the following warning message is displayed indefinitely.

**UNIT WARNING: !! LOW BATTERY !!
CHECK SETPOINTS/PROGRAM/OPTIONS/TIME**

If a low battery condition exists, all programmed setpoints, program values, time, schedule, and history buffers will have been lost. These values will all be reset to their default values, which may not be the desired operating values. Once a bad battery is detected, the unit will be prevented from running until the MANUAL OVERRIDE key is pressed. Once the MANUAL OVERRIDE key is pressed, the anti recycle timers will be set to the programmed default anti recycle time to allow the operator sufficient time to check setpoints, program values, etc.

If a low battery is detected, it should be replaced as soon as possible. The programmed values will all be lost and the unit will be prevented from running on the next power interruption.

Invalid Number of Compressors Warning

The INVALID NUMBER OF COMPRESSORS SELECTED Warning will occur after the VSD has been initialized, if no "Number of Compressors Select" jumpers are installed or if more than 1 jumper is installed. The following warning message will be displayed indefinitely.

**UNIT WARNING:
INVALID NUMBER OF COMPRESSORS SELECTED**

To clear this warning, both the control panel and VSD control voltage must be turned OFF and the jumpers properly installed in the VSD wiring harness.

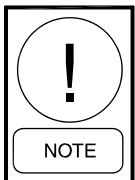

These jumpers are factory installed in the wire harness plug and should not require changes.

Invalid Serial Number Warning

If the INVALID SERIAL NUMBER message appears, immediately contact Johnson Controls Product Technical Support. The appearance of this message may mean the chiller has lost important factory programmed information. The serial number can be entered using the SERVICE key.

**UNIT WARNING: INVALID SERIAL NUMBER
ENTER UNIT SERIAL NUMBER**

This status message can be bypassed to view additional messages under the STATUS key by pressing the STATUS key repeatedly to scroll through as many as three STATUS messages that could possibly be displayed at any time.

UNIT SAFETIES

Unit Safety Operation

Unit faults are safeties that cause all running compressors to be shut down, if a safety threshold is exceeded for 3 seconds. Unit faults are recorded in the history buffer along with all data on the unit and system operating conditions. Unit faults are auto reset faults where the unit will be allowed to restart automatically after the fault condition is no longer present. The only exception is any of the VSD related unit faults. If any 3 VSD unit faults occur within 90 minutes, the unit will be locked out on the last fault. A VSD lockout condition requires a manual reset using the system switches. Both system switches must be cycled OFF and ON to clear a VSD unit lockout fault. If a unit safety is in effect, the message will be displayed to the operator when the STATUS key is pressed.

In the descriptions of the fault displays that follow, the fault message will show a YYYYYYYY to indicate that a system is in a "FAULT" condition and will restart when the fault clears or LOCKOUT" and will not restart until the operator clears the fault using the keypad.

If a control panel safety occurs after the VSD fault, but before the fault is reset, the control panel fault is an ALL FAULT of the VSD fault, meaning it will be registered as such in the History because it occurred while the VSD was shutting down or while the systems were shut down. All faults do not store operating data at the time of the fault.

If a "VSD" fault occurs during the fault ramp down or while the systems are shut down, the VSD fault will be registered as a new fault. The reason for this is the belief any VSD fault should be registered with a full account of the systems data at the time of the fault.

High Ambient Temp Fault

If the ambient temperature rises above 54°C (130°F), the chiller will shut down with a controlled ramped shutdown. Restart will automatically occur, if demand allows, when temperature falls 1.1°C (2°F) below the cutout (52.9°C [128°F]). This fault cannot cause a lockout. The fault display message will be present only during the time when the ambient temperature is causing a fault condition. A sample display is shown below:

**UNIT YYYYYYYY
HIGH AMBIENT TEMP**

The unit will also be inhibited from starting any time the temperature is above 52.9°C (128°F).

Low Ambient Temp Fault

If the ambient temperature falls below the programmable Low Ambient Temp Cutout the chiller will shut down with a controlled ramped shutdown. This fault will only occur if the Low Ambient Cutout is “ENABLED” under the OPTIONS key. Restart can occur, if demand allows, when temperature rises 1.1°C (2°F) above the cutout. This fault cannot cause a lockout. The fault display message will be present only during the time when the ambient temperature is causing a fault condition. A sample display is shown below:

```
UNIT YYYYYYYY
LOW AMBIENT TEMP
```

The unit is also inhibited from starting any time the temperature is below the cutout plus 1.1°C (2°F).

Low Leaving Chilled Liquid Temp Fault

The Low Leaving Chilled Liquid Temp Cutout helps to protect the chiller from an evaporator freeze-up should the chilled liquid temp drop below the freeze point. This situation could occur under low flow conditions or if the Micro Panel setpoint values are improperly programmed. Any time the leaving chilled liquid temperature (water or brine) drops below the programmable cutout point, the chiller will fault and shutdown with a controlled ramped shutdown. Restart can occur, if demand allows, when chilled liquid temperature rises 2.2°C (4°F) above the cutout. This fault cannot cause a lockout. A sample shutdown message is shown below:

```
UNIT YYYYYYYY
LOW LEAVING CHILLED LIQUID TEMP
```

The unit is inhibited from starting any time the chilled liquid temperature is below the cutout plus 2.2°C (4°F).

VSD Communications Failure Fault

The VSD Communications Failure is to prevent the unit from trying to run, if the Chiller Control Board never initializes communications with the VSD Logic Board. The unit will also shut down with a controlled ramped shutdown if the Chiller Control Board loses communications with the VSD Logic Board while the chiller is operating.

On power-up, the Chiller Microprocessor Board will attempt to initialize communications with the VSD Logic Board. The control panel will request data from the VSD, which includes the number of compressors and the VSD software version. Once these data points have been received by the Chiller Control Board, and have been successfully initialized, the Chiller Control Board will not request them again. If the comms connection fails to occur and a reply from the VSD Logic Board does not take place in 8 seconds, the Chiller Control Board will prevent the chiller from operating and a fault message will be displayed.

During normal operation, if the control panel Chiller Control Board receives no valid response to messages for 8 seconds, the unit will shut down all compressors on a Comms fault. The Chiller Control Board will continue to send messages to the VSD while faulted. The unit will be inhibited from starting until communications is established. The fault will automatically reset when the Chiller Control Board receives a valid response from the VSD for a data request. Shown below is an example of a Comms Failure fault message:

```
UNIT YYYYYYYY
VSD COMMUNICATIONS FAILURE
```

SYSTEM SAFETIES (FAULTS)

System Safety (Fault) Operation

System safeties are faults that cause individual systems to be shut down if a safety threshold is exceeded for 3 seconds. System faults are auto reset faults in that the system will be allowed to restart automatically after the 120 second anti-recycle timer times out. The only exception is after any 3 faults on the same system occur within 90 minutes, that system will be “locked out” on the last fault. The lockout condition requires a manual reset using the system switch. The respective system switch must be cycled OFF and ON to clear the lockout fault.

When multiple systems are operating and a system fault occurs, the running systems will ramp down and the faulted system will be shut OFF and the previously operating will restart if required after the fault clears and/or the 120 second anti-recycle timer times out.

In the descriptions of the fault displays that follow, the fault message will show a YYYYYYYY to indicate that a system is in a “FAULT” condition and will restart when the fault clears, or “LOCKOUT” and will

not restart until the operator clears the fault using the keypad. If a system safety is in effect, the message will be displayed to the operator when the STATUS key is pressed.

In some cases, a control panel fault will occur after a VSD fault, possibly during system shutdown or at some later time. This is known as an “ALL FAULT” and these faults will be recorded as such under the HISTORY information stored at the instant of the primary fault. In some cases, this information may be valuable in troubleshooting the primary fault. An example of the “ALL FAULT” history message is shown on Page 84 under the HISTORY key. When an “ALL FAULT” occurs, associated history information will not be stored. If an additional fault does not occur, the “ALL FAULTS” display will indicate NONE.

In cases where a VSD fault occurs during the rampdown of a control panel fault (i.e.: low suction pressure, low water temp, etc.), the VSD fault will be stored as a new fault with the associated fault information stored at the instant the VSD fault occurred (i.e.: IGBT Gate Drive, Single Phase Input, VSD CT Plug, etc.). The control panel fault that occurred prior to the VSD fault will be stored with the associated complete data related to the fault as a numerically lower numbered history in the history buffers.

High Discharge Pressure Cutout (Software) Fault

The High Discharge Pressure Cutout is a software fault. A system will fault and shut down with a controlled ramped shutdown on high discharge pressure when the discharge pressure rises above 22.4 barg (325 PSIG) for 0.5 seconds. The system will be allowed to restart when the discharge pressure falls to 20.3 barg (295 PSIG). The system will also be inhibited from starting if the pressure is above 20.3 barg (295 PSIG). The fault message for this safety is shown below:

SYS X YYYYYYYY HIGH DISCHARGE PRESSURE

The X indicates the system and YYYYYYYY indicates the system is in a “FAULT” condition and will restart when the 120 second anti-recycle timer times out, or “LOCKOUT” and will not restart until the operator clears the fault using the keypad.

High Discharge Pressure Cutout (HPCO) (Hardware) Fault

The mechanical High Pressure Cutout protects the system from experiencing dangerously high discharge pressure. A system will fault and shut down immediately when the mechanical high pressure cutout contacts open. The fault will occur immediately and not wait 3 seconds, which is typical of most system faults. The HPCO is wired in series with the VSD Run Signal and will only be checked by the Chiller Control Board when the system is running. The mechanical cutout opens at 23.2 barg \pm 0.70 barg (337 PSIG \pm 10PSIG) and closes at 15.9 barg \pm 0.70 barg (230 PSIG \pm 10 PSIG). The Status display fault message for this system is shown below:

SYS X YYYYYYYY HPCO FAULT

The X indicates the system and YYYYYYYY indicates the system is in a “FAULT” condition and will restart when the 120 second anti-recycle timer times out or “LOCKOUT” and will not restart until the operator clears the fault using the keypad.

Low Suction Pressure Cutout (Software) Fault

The programmable Low Suction Pressure Cutout is a secondary back-up for the flow switch and protects against operation with low refrigerant charge, which helps protect the chiller from an evaporator freeze-up, should the system attempt to run with a low refrigerant charge. The Status display fault message for this cutout is shown below:

SYS X YYYYYYYY LOW SUCTION PRESSURE

The X indicates the system and YYYYYYYY indicates the system is in a “FAULT” condition and will restart when the 120 second anti-recycle timer times out or “LOCKOUT” and will not restart until the operator clears the fault using the keypad. Typically, the cutout will be set at 1.65 barg (24 PSIG) for chilled water applications.

The cutout is ignored for the first 30 seconds of system run time. During the next 3 minutes of run time the cutout point is linearly ramped from 10% of the cutout value up to the programmed cutout point. If at any time during the first 3 minutes of operation the suction pressure falls below the ramped cutout point, the system will shut down with a controlled ramped shutdown.

The cutout pressure during operating periods of 30 seconds to 210 seconds is ramped and can be calculated by:

$$Cutout = \frac{(Programmed\ Cutout \times Run\ Time)}{200} - 1.2PSIG$$

After the first 3 minutes and 30 seconds of run time, if the suction pressure falls below the cutout as a result of a transient in the system, a transient timer is set at 30 seconds and a linearly ramped cutout is set starting at 10% of the programmed cutout. If over the next 30 seconds, the suction pressure does not stay above the ramped cutout, which ramps between 10% of the cutout and the programmed cutout over the 30 second period, the system will fault on low suction pressure.

Low Motor Current Cutout Fault

The Motor Current Cutout shuts the system down with a controlled ramped shutdown when the microprocessor detects the absence of motor current (less than 10% FLA), usually indicating that a compressor is not running. This safety is ignored for the first 10 seconds of operation.

The status display fault message for this safety is shown below:

SYS X YYYYYYYY LOW MOTOR CURRENT

The X indicates the system and YYYYYYYY indicates the system is in a “FAULT” condition and will restart when the 120 second anti-recycle timer times out or “LOCKOUT” and will not restart until the operator clears the fault using the keypad.

High Differential Oil Pressure Cutout Fault

The High Differential Oil Pressure Cutout protects the compressor from low oil flow and insufficient lubrication, possibly from a dirty oil filter. A system will fault and shut down with a controlled ramped shutdown when its Discharge to Oil Differential Pressure rises above the cutout of 4.48 bard (65 PSID). This safety is ignored for the first 90 seconds of run time. This safety measures the pressure differential between discharge and oil pressure, which is the pressure drop across the oil filter. The Status display fault message for this safety is shown below:

SYS X YYYYYYYY HIGH DIFF OIL PRESSURE

The X indicates the system and YYYYYYYY indicates the system is in a “FAULT” condition and will restart

when the 120 second anti-recycle timer times out or “LOCKOUT” and will not restart until the operator clears the fault using the keypad.

Low Differential Oil Pressure Cutout Fault

The Low Differential Oil Pressure Cutout protects the compressor from low oil flow and insufficient lubrication. A system will fault and shut down with a controlled ramped shutdown when it’s differential between oil and suction pressure falls below the cutout. This safety assures that the compressor is pumping sufficiently to push oil through the oil cooling circuit and through the internal compressor lubrication system. The Status display fault message for this safety is shown below:

SYS X YYYYYYYY LOW DIFF OIL PRESSURE

The X indicates the system and YYYYYYYY indicates the system is in a “FAULT” condition and will restart when the 120 second anti-recycle timer times out or “LOCKOUT” and will not restart until the operator clears the fault using the keypad.

The safety is ignored for the first 60 seconds of run time. After the first 60 seconds of operation, the cutout is linearly ramped from 0 bard to 2.09 bard (0 PSID to 30 PSID) in 5 to 10 minutes based on ambient temperature. See the following table for the ramp times for the given ambient temperatures.

TABLE 12- LOW DIFFERENTIAL OIL PRESSURE CUTOUT

AMBIENT TEMPERATURE	RAMP TIME
more than 10°C (50°F)	5 minutes
more than 7.2°C (45°F)	6 minutes
more than 4.4°C (40°F)	7 minutes
more than 1.6°C (35°F)	8 minutes
more than 1.1°C (30°F)	9 minutes
more than or equal to 1.1°C (30°F)	10 minutes

A 30 second safety bypass below 50 Hertz is employed during ramp down. The bypass is primarily needed under conditions where another compressor is being brought on and the running compressor is being ramped down to 5 Hertz to add the additional compressor due to load requirements. Under these conditions, the slow speed of the running compressor(s) causes the oil differential to become very low, especially if the water temperature is high and the suction pressure is high. The bypass assures the compressor(s) will not trip on a nuisance low oil differential fault.

High Discharge Temperature Cutout Fault

The High Discharge Temperature Cutout protects the motor and compressor from overheating. A system will fault and shut down with a controlled ramped shutdown when its Discharge Temperature rises above 121°C (250°F). A system will also be inhibited from starting if the discharge temperature is above 93°C (200°F). The Status display fault message for this safety is shown below:

```
SYS X YYYYYYYY HIGH DISCHARGE TEMP
```

The X indicates the system and YYYYYYYY indicates the system is in a “FAULT” condition and will restart when the 120 second anti-recycle timer times out or “LOCKOUT” and will not restart until the operator clears the fault using the keypad.

Low Discharge Superheat Cutout Fault

The Low Discharge Superheat safety helps protect the compressor from liquid flood back through the economizer line due to a high flash tank level. It also helps protect the compressor from excessive oil in circulation due to excess oil charge in the system. Excessive oil in circulation brings back liquid refrigerant which is entrained in the oil. The liquid then drops out once it enters the compressor.

The safety is ignored for the first 10 minutes of operation if the system economizer feed valve is closed (0%) and for 5 minutes of operation if the economizer feed valve is open greater than 0%. If the discharge superheat falls below 2.8°C (5.0°F) for 5 minutes under either condition, the system will shut down.

```
SYS X YYYYYYYY LOW DISCHARGE SUPERHEAT
```

The X indicates the system and YYYYYYYY indicates the system is in a “FAULT” condition and will restart when the 120 second anti-recycle timer times out or “LOCKOUT” and will not restart until the operator clears the fault using the keypad.

Sensor Failure Cutout Fault

The Sensor Failure Cutout prevents the system from running when a critical sensor (transducer, level sensor, or motor winding temp sensor) is not functioning properly and reading out of range. This safety is checked at startup and will prevent the system from running if one of the sensors has failed.

The sensor failure safety will also fault and shutdown a system while in operation, if a safety threshold is exceeded or a sensor reads out of range (high or low). Following is the Status display fault message.

```
SYS X YYYYYYYY SENSOR FAILURE:
ZZZZZZZZZZ
```

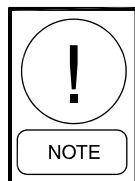

The X indicates the specific system. YYYYYYYY will either indicate the system is in a “FAULT” condition and will restart when the fault clears, or “LOCKOUT” after 3 faults and will not restart until the operator clears the fault using the keypad.

ZZZZZZZZZZ indicates the failed sensor below:

- SUCT PRESS
- OIL PRESS
- DSCH PRESS
- MOTOR TEMP X *

*The Unit Setup Mode allows a specific motor temperature sensor to be ignored, if it fails.

The start inhibit thresholds for each sensor are shown in the following table.

TABLE 13 - START INHIBIT SENSOR THRESHOLDS

SENSOR	LOW THRESHOLD	HIGH THRESHOLD
SUCTION TRANSDUCER	0.3VDC	4.7VDC
OIL TRANSDUCER	0.3VDC	4.7VDC
DISCHARGE TRANSDUCER	0.3VDC	4.7VDC
MOTOR TEMP.SENSOR	0°C (0°F)	116°C (240°F)

High Motor Temperature Cutout Fault

The High Motor Temperature Cutout prevents a compressor from running when its motor temperature is too high. A system will fault and shut down when any compressor motor temperature sensor rises above 121°C (250°F). The system will be inhibited from starting if its motor temperatures sensors indicate temperatures above 116°C (240°F). If any single temperature sensor is being ignored under the Unit Set-up Mode, that sensor will not be utilized when evaluating motor temperature.

Below is a sample Status display fault message:

SYS X YYYYYYYY HIGH MOTOR TEMP

The X indicates the system and YYYYYYYY indicates the system is in a “FAULT” condition and will restart when the fault clears or “LOCKOUT” and will not restart until the operator clears the fault using the keypad.

System Control voltage Cutout Fault

The System Control Voltage Cutout alerts the operator the 115VAC Control voltage to one of the systems is missing. This could be due to a system fuse that has been removed or is blown. The affected system will fault and shut down immediately when the 115VAC supply is lost.

The safety will “not” shut down a system if the UNIT switch is OFF, which electrically removes the 115VAC to “all” systems. The safety is only used to indicate a situation where a single system is missing the 115VAC. The safety will not cause a lockout and the system fault will reset when power is returned. A sample message is shown below:

SYS X YYYYYYYY CONTROL VOLTAGE

The X indicates the system and YYYYYYYY indicates the system is in a “FAULT” condition and will restart when the fault clears or “LOCKOUT” and will not restart until the operator clears the fault using the keypad.

Eductor Clog Fault

To sense a loss of oil return to the compressor, an eductor clog detection safety is utilized. The safety monitors the temperature of the line between the eductor and the suction line.

The control algorithm looks at the eductor line temperature once a second. At start, a clog timer is set at 600 seconds. If the eductor line temperature is less than the saturated suction temperature plus 5.5°C (10°F) each time the control circuit looks at the temperature, the clog timer is reset to 600 seconds.

If the eductor line temperatures is greater than the saturated suction temperature plus 5.5°C (10°F), the clog timer is decremented one second. If the temperature remains above the saturated suction temperature plus 5.5°C (10°F) for 600 seconds, the clog timer will count to “0” and the system will shut down and lock out. The status fault will indicate an eductor clog fault.

EDUCTOR CLOG FAULT

Whenever this fault occurs, the eductor filter should be changed.

The clog timer resets to 600 seconds whenever the control algorithm sees the eductor line temperature is less than the saturated suction pressure plus 5.5°C (10°F). This prevents nuisance eductor clog faults.

SECTION 8 - MICROPANEL STATUS KEY

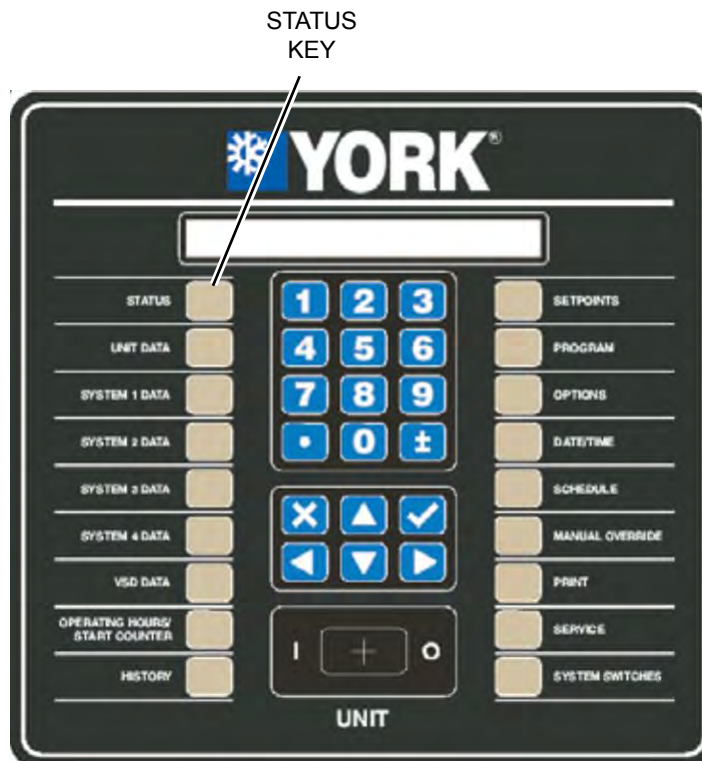

LD10605

STATUS KEY OPERATION

The STATUS key displays the current chiller or system operational status. The messages displayed include running status, cooling demand, system faults, unit faults, VSD faults, unit warnings, external device status, load limiting, anti-recycle timer, status of unit/system switches, and a number of other messages. Pressing the STATUS key will enable the operator to view the current status of the chiller. The display will show one message relating to the “highest priority” information as determined by the microprocessor. There are three types of status data, which may appear on the display:

- General Status messages
- Unit Safeties
- System Safeties.

When power is first applied to the control panel, the following message displaying York International Corporation, the EPROM version, date, and time will be displayed for 2 seconds, followed by the appropriate general status message:

```
(C)2004 YORK INTERNATIONAL CORPORATION
C.XXX.XX.XX 18-SEPT-2010 12:45: AM
```

Unit status messages occupy 2 lines of the Status message display. If no unit status message applies, individual status messages for each system will be displayed.

Any time the STATUS key is pressed or after the EPROM message disappears at power-up, a status display indicating chiller or system status will appear.

Multiple STATUS messages may appear and can be viewed by pressing the STATUS key repeatedly to allow scrolling through as many as three STATUS messages, which could possibly be displayed at any time on a 2 compressor chiller.

Examples of the typical Status messages are shown in the next topic

General Status Messages

```
UNIT STATUS
MANUAL OVERRIDE
```

This message indicates the chiller is operating in MANUAL OVERRIDE mode. This message is a priority message and cannot be overridden by any other STATUS message. When in Manual Override, no other status message will ever be present.

UNIT STATUS
UNIT SWITCH OFF SHUTDOWN

This message indicates the UNIT SWITCH is in the OFF position and not allowing the unit to run.

UNIT STATUS
DAILY SCHEDULE SHUTDOWN

This message indicates that either the daily or holiday schedule programmed is keeping the chiller from running.

UNIT STATUS
REMOTE CONTROLLED SHUTDOWN

This message indicates that either an ISN or RCC has turned the chiller OFF and is not allowing it to run.

UNIT STATUS
FLOW SWITCH SHUTDOWN

This message indicates the flow switch is not allowing the chiller to run. There is a 1 second delay on this safety to assure the flow switch did not momentarily open.

UNIT STATUS
VSD COOLING SHUTDOWN

This message indicates the chiller is shutdown, but running all the condenser fans, VSD glycol pump, and VSD fan in an effort to bring the internal VSD ambient temperature down to an acceptable level before allowing the chiller to start.

SYS X REMOTE RUN CONTACT IS OPEN

This message indicates the remote start/stop contact between 2 and 15 or 2 and 16 of the 1TB terminal block is open. There is a 1 second delay on this safety to assure the remote contacts did not momentarily open.

SYS X SYSTEM SWITCH IS OFF

This message indicates the system switch (software via keypad) is turned OFF. The system will not be allowed to run until the system switch is turned ON via the keypad.

SYS X NOT RUNNING

This message indicates the system is not running because the chilled liquid is below the setpoint or the micro has not loaded the lead system far enough into

the loading sequence to bring the lag system ON. This message will be displayed on the lag system until the loading sequence is ready for the lag system to start.

SYS X COOLING DEMAND SHUTDOWN

This message is only displayed in the Normal Shutdown. History display to indicate a capacity control shutdown.

SYS X COMPRESSOR RUNNING

This message indicates the system is running as a result of cooling demand.

SYS X SHUTTING DOWN

The compressor shutting down message indicates the respective system is ramping down in speed prior to shutting OFF. This message is displayed after the software run signal is disabled until the VSD notifies the Chiller Control Board the compressor is no longer running.

SYS X ANTI-RECYCLE TIMER = XXX SEC

This message indicates the amount of time left on the respective system anti-recycle timer and the system is unable to start until the timer times out.

SYS X DISCHARGE PRESSURE LIMITING

The Discharge Pressure Limiting message indicates the discharge pressure load limit or discharge pressure unloading is in effect.

SYS X SUCTION PRESSURE LIMITING

The Suction Pressure Limiting message indicates the suction pressure load limit or suction pressure unloading is in effect.

SYS X MOTOR TEMP LIMITING

The Motor Temp Limiting message indicates the motor temp load limit or motor temp unloading is in effect.

SYS X MOTOR CURRENT LIMITING

The motor current limiting message indicates the motor current load limit or motor current unloading is in effect.

SYS X PULLDOWN MOTOR CURRENT LIMITING

The pulldown motor current limiting message indicates the pulldown motor current load limit or pulldown motor current unloading is in effect based on the programmed setpoint.

SYS X ISN CURRENT LIMITING

The ISN Current Limiting message indicates the motor current load limit or motor current unloading is in effect through the use of the YORKTalk setpoint.

SYS X REMOTE MOTOR CURRENT LIMITING

The Remote Motor Current Limiting message indicates the motor current load limit or motor current unloading is in effect through the use of the remote setpoint offset. The setpoint may be offset using a remote voltage or a current signal. The remote current limit must be activated for this function to operate.

SYS X VSD BASEPLATE TEMP LIMITING

The VSD Baseplate Temp Limiting message indicates the VSD Baseplate temp is high and load limit or unloading is in effect.

SYS X VSD INTERNAL AMBIENT TEMP LIMITING

The VSD Internal Ambient Temp Limiting message indicates the VSD internal ambient temp is high and load limit or unloading is in effect.

SYS X SOUND LIMITING

The sound limiting message indicates the sound load limit is in effect based on the locally programmed sound limit from the keypad. The sound limit must be activated for this function to operate.

SYS X ISN SOUND LIMITING

The ISN sound limiting message indicates the sound load limit is in effect based on the ISN transmitted sound limit setpoint. The sound limit must be activated for this function to operate.

SYS X REMOTE SOUND LIMITING

The Remote sound limiting message indicates the sound load limit is in effect based on the Remote controlled sound limit setpoint. The setpoint may be offset using a remote voltage or current signal. The sound limit option must be activated for this function to operate.

UNIT DATA KEYUNIT DATA
KEY

LD10605

General

The UNIT DATA key provides the user with displays of unit temperatures, and unit related data. Displays can be selected by repeatedly pressing the UNIT DATA key or the ▲ or ▼ Arrow Keys.

Unit Data Key Operation

The first key press displays Evaporator Leaving and Return Chilled Liquid Temperatures.

UNIT CHILLED LIQUID LEAVING = XXX.X °F
ENTERING = XXX.X °F

The next key press of the UNIT DATA key or the ▼ (ARROW) key displays the ambient air temperature.

UNIT
OUTSIDE AMBIENT AIR TEMP = XXX.X °F

The next key press will display the time remaining on the load and unload timers.

UNIT
LOAD TIMER = XXX SEC
UNLOAD TIMER = XXX SEC

The next key press displays the error in temperature between the actual leaving chilled liquid temperature and the setpoint temperature. The display also shows the rate of change of the chilled liquid temperature.

UNIT
TEMP ERROR = XXX.X °F
RATE = XXX.X °F/M

The next key press displays the system designated as the lead system and the Flow Switch status (ON or OFF).

UNIT LEAD SYSTEM NUMBER = X
FLOW SWITCH = XXX

The next key press displays the status of the evaporator pump and heater, where XXX is either ON or OFF.

UNIT
EVAP PUMP RUN = XXX
EVAP HEATER = XXX

The next key press displays the status of Active Remote Control.

UNIT ACTIVE REMOTE CONTROL = XXXXXX
TYPE: RCC ISN CURR TEMP SOUND

XXXXXX is either ACTIVE or NONE.

If no remote keys are active, the items on the second line are all blanked out. Any remote items that are active will be displayed, while the inactive items will be blanked out.

The types of remote control are listed as follows:

- NONE - No remote control is actively controlling the chiller; however, remote monitoring by a remote device may still be active.
- RCC - A Remote Control Center is providing remote control. The chiller is in remote mode.
- ISN - YorkTalk via ISN. The chiller in remote mode.
- CURR - Remote Current Limiting is enabled.
- TEMP - Remote Temperature Reset is enabled.
- SOUND - Remote Sound Limiting is enabled.

The next key press displays the sound limit values as set under the PROGRAM key by the Local, ISN, and the Remote Sound Limit Inputs. Any sound limits that are inactive will display XXX instead of a numeric value.

UNIT SOUND LIMIT	LOCAL = XXX %
ISN = XXX	REMOTE = XXX %

SYSTEM DATA KEYS 1 THROUGH 4

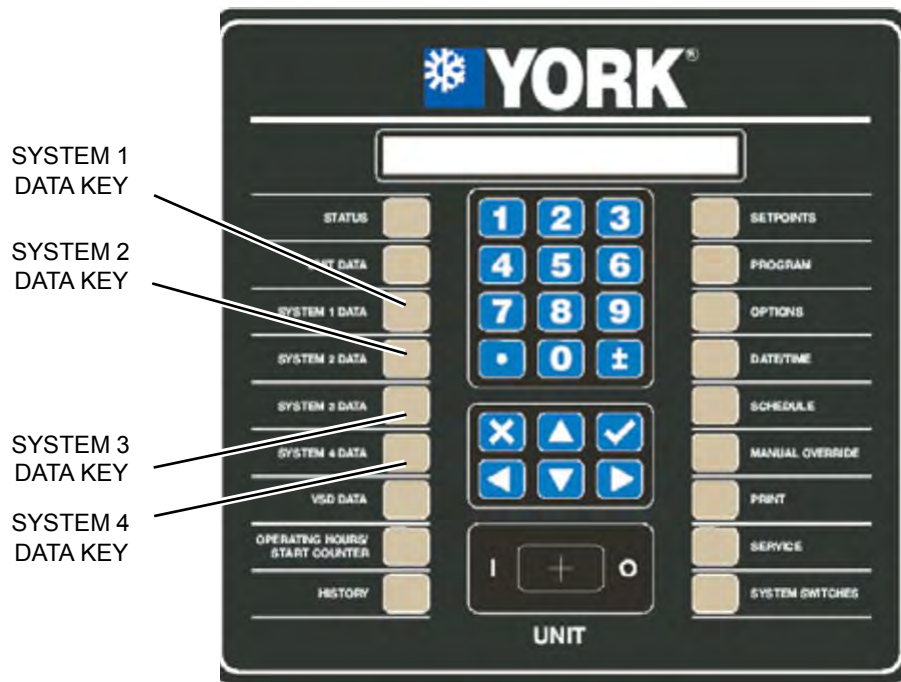

LD10605

General

The data keys provide the user with many displays of individual system temperatures, pressures, and other operating data. These keys have multiple displays, which can be seen by repeatedly pressing the SYSTEM DATA or the ▲ or ▼ (Arrow) keys. An explanation of each key and its messages is provided below.

System 1 Data Key Operation

The SYSTEM 1 DATA key provides the user with access to System 1 operating parameters. The following is a list of the data in the order in which it appears.

The first key press of the SYSTEM X DATA key displays all of the measured system pressures (oil and discharge).

SYS 1 PRESSURES OIL = XXXX PSIG
DISCHARGE = XXXX PSIG

The second key press of the SYSTEM DATA key or the ▼ (DOWN ARROW) key displays system suction and condenser liquid pressure.

SYS 1 PRESSURES SUCTION = XXXX PSIG
CONDENSER LIQUID = XXXX PSIG

The next key press displays system oil and eductor temperatures.

SYS 1 TEMPERATURES OIL = XXX.X °F
EDUCTOR = XXX.X °F

The next key press displays system condenser liquid temperature, liquid line subcooling and saturated discharge temperature on the liquid line.

SYS 1 CONDENSER LIQUID TEMP = XXX.X °F
SUBCOOLING = XXX.X SAT TEMP = XXX.X °F

The next key press displays discharge temperature, discharge superheat and saturated discharge pressure at the compressor.

SYS 1 DISCHARGE TEMP = XXX.X °F
SUPERHEAT = XXX.X SAT TEMP = XXX.X °F

The next key press displays the System 1 motor thermistor temperatures.

SYS 1 MOTOR TEMPS T1 = XXX.X °F
T2 = XXX.X °F T3 = XXX.X °F

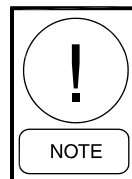

If any motor temp sensor is being ignored, (selectable under Unit Set-up Mode), that sensor's value will be displayed as XXXXX.

Sensor Displays

Table 14 lists all the sensors attached to the control board associated with system data keys. The minimum and maximum values displayed on the micro display are provided.

If values exceed the limits in the table, a < (less than) or > (more than) sign will be display along with the minimum or maximum value.

TABLE 14- SENSOR MIN/MAX OUTPUTS

SYSTEM SENSOR			
SENSOR / INPUT	TYPE	MINIMUM VALUE	MAXIMUM VALUE
Suction Pressure	Transducer	0.0 PSIG (0 barg)	125.0 PSIG (8.62 barg)
Condenser Liquid Pressure	Transducer	0.0 PSIG (0 barg)	400.0 PSIG (27.6 barg)
Discharge Pressure	Transducer	0.0 PSIG (0 barg)	400.0 PSIG (27.6 barg)
Oil Pressure	Transducer	0.0 PSIG (0 barg)	400.0 PSIG (27.6 barg)
Flash Tank Level	Capacitance	0.0%	100%
Condenser Liquid Temp	Thermistor	-4.1 °F (-20.06 °C)	155.6 °F (68.67 °C)
Leaving Chilled Liquid Temp	Thermistor	-19.1 °F (-28.49 °C)	110.2 °F (43.44 °C)
Return Chilled Liquid Temp	Thermistor	-19.1 °F (-28.49 °C)	110.2 °F (43.44 °C)
Eductor Temp	Thermistor	-4.1 °F (-20.06 °C)	132.8 °F (56.00 °C)
Ambient Air Temp	Thermistor	-4.6 °F (-20.33 °C)	137.9 °F (58.83 °C)
Compressor motor Temp	Thermistor	-30.2 °F (-34.56 °C)	302.0 °F (150.00 °C)
Discharge Temp	Thermistor	40.3 °F (4.61 °C)	302.6 °F (150.33 °C)
Remote Temp Reset	4 to 20ma, 0 to 10VDC, 0 to 20ma or 2 to 10VDC	0%	100%
Remote Current Limit	4 to 20ma, 0 to 10VDC, 0 to 20ma or 2 to 10VDC	0%	100%
Remote Sound Limit	4 to 20ma, 0 to 10VDC, 0 to 20ma or 2 to 10VDC	0%	100%

VSD DATA KEY



LD10605

8

General

The VSD DATA key provides the user with displays of VSD temperatures, voltages, currents, and other operating data. This key has multiple displays, which can be seen by repeatedly pressing the VSD DATA or the ▲ or ▼ (Arrow) keys. An explanation of each message is provided below.

VSD Data Key Operation

The first VSD DATA key press displays the actual VSD Output Frequency and Command Frequency.

VSD FREQUENCY ACTUAL = XXX.X Hz
COMMAND = XXX.X Hz

The second key press of the VSD DATA key or the ▼ (ARROW) key displays the calculated compressor % FLA and measured motor currents in amps for systems 1 and 2. When measuring motor current keep in mind that measuring inverter PWM current is difficult and meter error can be significant.

VSD COMP 1 = XXX AMPS = XXX %FLA
COMP 2 = XXX AMPS = XXX %FLA

The next key press displays the current limit values set locally on the panel under the PROGRAM key, remotely by an ISN, and remotely by the Current Limit input. Any current limits that are inactive will display “XXX” instead of a numeric value.

VSD CURRENT LIMIT LOCAL = XXX %FLA
ISN = XXX REMOTE = XXX %FLA

The next key press displays DC Bus voltage.

VSD DC BUS VOLTAGE = XXX VDC

The next key press displays the Control Panel/VSD Internal Ambient Temperature and VSD Cooling Pump/Fan Status. YYY will indicate ON or OFF.

VSD INTERNAL AMBIENT TEMP = XXX.X °F
COOLING SYSTEM STATUS = YYY

The next key press displays the IGBT highest baseplate temperature.

VSD IGBT BASEPLATE TEMPS T1 = XXX
°F T2 = XXX

The next key press displays the state of the Precharge signal, where XXX is either ON or OFF.

VSD PRECHARGE SIGNAL = XXX

The next key press displays the setting of the VSD’s 105% FLA overload potentiometer for Compressor #1 and 2. The settings are determined by the adjustment of the overload potentiometers on the VSD Logic Board. These pots are factory set and should not require changing unless the circuit board is replaced.

VSD COMP 1 MOTOR OVERLOAD = XXX AMPS
COMP 2 MOTOR OVERLOAD = XXX AMPS

OPERATING HOURS / START COUNTER KEY

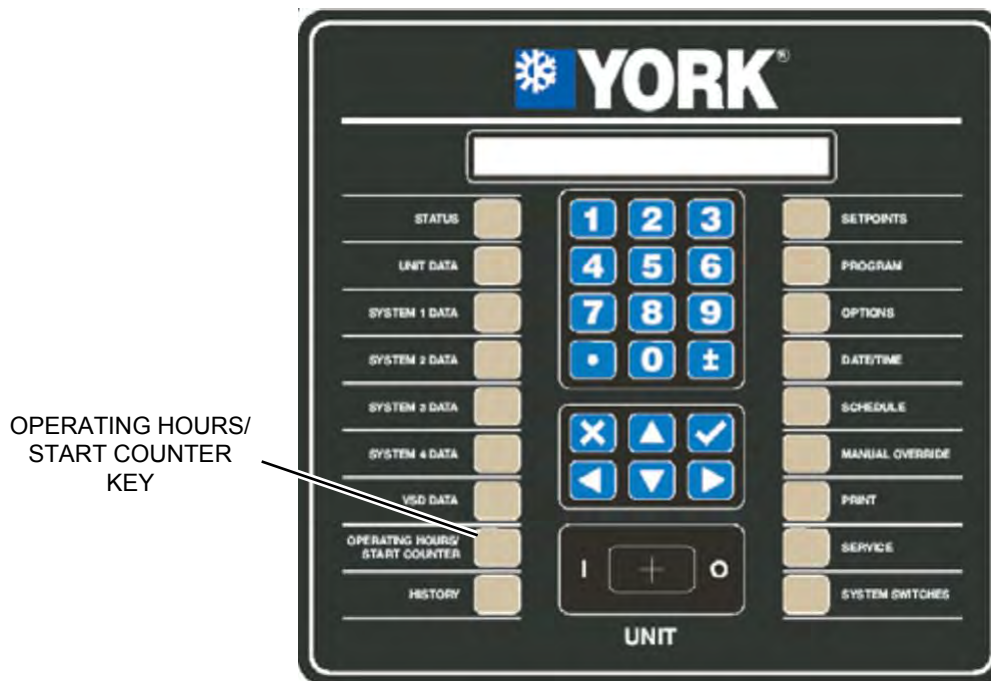

LD10605

Compressor operating hours and compressor starts are displayed with a single key press. The maximum value for both hours and starts is 99,999, at which point they will roll over to 0. A single display is available under this key and is displayed below.

HOURS 1=XXXXX, 2=XXXXX

START 1=XXXXX, 2=XXXXX

HISTORY KEY

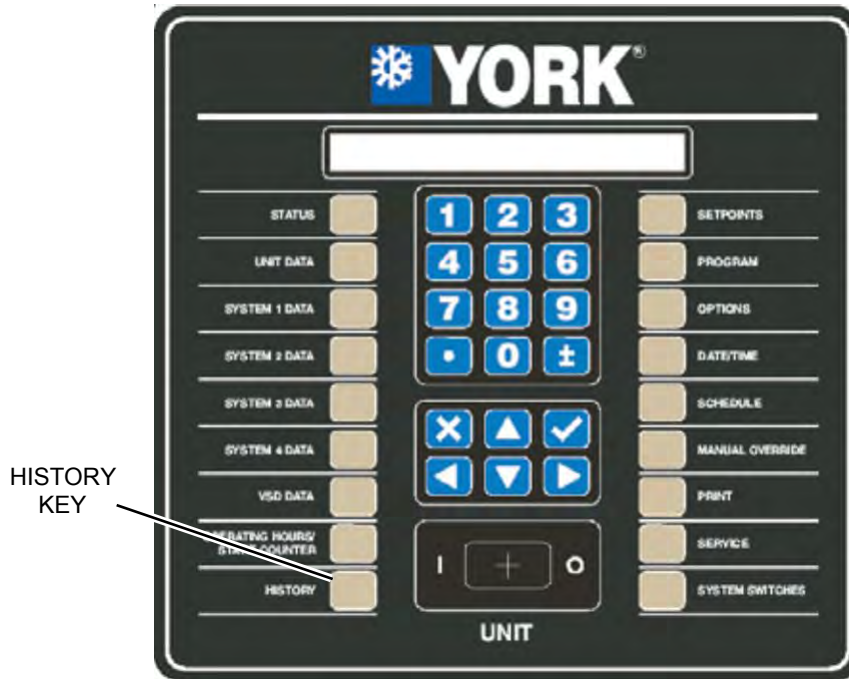

LD10605

History Key Operation

The HISTORY key provides the user access to many unit and system operating parameters captured at the instant a unit or system safety (fault) shutdown occurs. The history buffer will also capture system data at the time of normal shutdowns such as cycling shutdowns. When the HISTORY key is pressed the following screen is displayed:

```
HISTORY      CHOOSE HISTORY TYPE
◀ ▶  XXXXXXXXXXXXXXXXXXXXXXXXXXXXXXXXXXXX
```

The ◀ and ▶ (ARROW) keys allow choosing between NORMAL SHUTDOWNS and FAULT SHUTDOWNS. “Fault” shutdowns provide information on safety shutdowns, while “Normal” shutdowns provide chiller cycling information on temperature (demand), cycling, remote, system switch, etc., shutdowns that are non-safety related shutdowns. Once the selection is made, the ✓ (ENTER) key must be pressed to enter the selection.

Normal Shutdowns History

If the NORMAL SHUTDOWNS History is selected, the following screen will be displayed:

```
NORM HIST XX 18-JUN-20004 10:34:58 AM
XXXXXXXXXXXXXXXXXXXXXXXXXXXXXXXXXXXXXXXX
```

XX is the normal shutdown number. The display will provide date and time of the shutdown and the reason for the cycling shutdown (YYY....).

The operator can view any of the stored 20 single display normal shutdown history buffers. History buffer number 1 provides the most recent shutdown information and buffer number 20 is the oldest safety shutdown information saved. The ◀ and ▶ (ARROW) keys allow scrolling between each of the history buffers. The ▶ (ARROW) key scrolls to the next normal history shutdown and the ◀ (ARROW) key scrolls to the previous normal history shutdown.

The following display will typically be displayed on a normal shutdown due to shutdown on lack of cooling demand.

```
NORM HIST XX 18-JUN-20004 10:34:58 AM
SYS X COOLING DEMAND SHUTDOWN
```

Fault Shutdowns History

If the FAULT SHUTDOWNS History is selected, the following screen will be displayed:

```
FAULT HIST XX 18-JUN-20004 10:34:58 AM
XXXXXXXXXXXXXXXXXXXXXXXXXXXXXXXXXXXXXXXX
```

XX is the FAULT HISTORY shutdown number. The display will provide the date, time, and a description of the specific type of fault that occurred (YYY....).

The operator can view any of the stored 10 fault history buffers. History buffer number 1 provides the most recent safety shutdown information and buffer number 10 is the oldest safety shutdown information saved. The ◀ and ▶ arrow keys allow scrolling between each of the FAULT HIST buffers 1 through 10. The ▲ (UP) and ▼ (DOWN) arrow keys can be used to scroll forwards and backwards through the data in a specific history buffer, once it is displayed.

There is a large amount of data provided under each history. Rather than scroll sequentially through the data in a history, which is possible using the ▼ arrow key, the use of a combination of the ◀, ▶, ▲, and ▼ arrow keys allows fast scrolling to specific data the user desires to view. To use this feature, the user needs to be aware the ◀ and ▶ arrow keys allow scrolling to the top of the data subgroups. Once a specific history is selected, the history data is divided under the subgroups of Unit Data, VSD Data, System Data, Hours/Starts, Setpoints, Options, and Program data. The ◀ and ▶ arrow keys allow moving to the first display under the next or previous subgroup at any time. Once the first display of a subgroup is displayed, the ▲, and ▼ arrow keys allow scrolling through the data in the subgroup. The ▼ arrow key allows scrolling through the data from first to last. When the last piece of data is displayed, the next press of the ▼ arrow key scrolls to the first piece of data in the next subgroup. The ▲ arrow key allows going to the previous display.

Listed below is a description of the fault data displays and their meaning. Data will be displayed in a specific order starting with the Status Display (System Faults only), Fault Display, All Fault Display, Unit Data, VSD Data, System Data, Operating Hours/Starts, Setpoints, Options, and Program Values at the time of the fault.

Status Fault Type

```
SYS X COMPRESSOR RUNNING
SYS X YYYYYYYY HIGH DIFF OIL PRESSURE
```

This message indicates the type of system fault. This screen is skipped if a UNIT Fault caused the shutdown.

Unit Fault Type

```
UNIT FAULT
LOW AMBIENT TEMP
```

This message indicates the type of unit fault. This screen is skipped if a SYSTEM Fault caused the shutdown.

All Fault Data

```
FAULT HIST XX ALL FAULTS ZZ OF WW
YYYYYYYYYYYYYYYYYYYYYYYYYYYYYYYYYYYY
```

The ALL FAULT display indicates whether a fault occurred while the unit is shutting down on another fault.

If a control panel fault occurred while the unit is shutting down on a VSD fault before it is reset, the control panel fault is an ALL FAULT of the VSD fault.

If another VSD fault occurs while the unit is shutting down on a VSD fault, the next VSD fault will be registered as an ALL FAULT of the VSD fault.

If a VSD fault occurs during the ramp down shutdown of a control panel fault, the VSD fault is registered as a new fault, not an ALL FAULT

XX is the history number, YYY is the ALL FAULT description, ZZ is the ALL FAULT number and WW is the total number of All Faults for the current history. Sometimes, multiple faults may occur during the shutdown and multiple displays will be observed when scrolling through the data using the ▼ arrow. In most cases, the ALL FAULT display will indicate NONE. The ALL FAULT display will only indicate the cause of the fault. No additional chiller information will be displayed under the ALL FAULT, since a snapshot of all chiller data was taken at the time of the first fault.

Unit Data

Evaporator Leaving and Entering Chilled Liquid Temperatures

```
UNIT CHILLED LIQUID LEAVING = XXX.X °F
ENTERING = XXX.X °F
```

This message indicates the leaving and entering chilled liquid temperatures at the time of the fault.

Ambient Air Temperature

```
UNIT
OUTSIDE AMBIENT AIR TEMP = XXX.X °F
```

This message indicates the ambient air temperature at the time of the fault.

Load / Unload Timers

```
UNIT          LOAD TIMER = XXX SEC
              UNLOAD TIMER = XXX SEC
```

This message indicates remaining time on the load and unload timers at the time of the fault.

Chilled Liquid Temperature Error and Rate of Change

```
UNIT          TEMP ERROR = XXX.X °F
              RATE = XXX.X °F/M
```

This message indicates the temperature error between the actual and the programmed setpoint at the time of the fault and the rate of temperature change.

Programmed Lead System Selection and Flow Switch Status

```
UNIT  LEAD SYSTEM NUMBER = X
              FLOW SWITCH = XXX
```

This message indicates the designated lead system at the time of the fault and whether the flow switch was ON (Closed) or OFF (Open) at the time of the fault.

Evaporator Pump and Evaporator Heater Status

```
UNIT          EVAP PUMP RUN = XXX
              EVAP HEATER = XXX
```

This message indicates the status of the evaporator pump and the evaporator heater at the time of the fault. XXX indicates ON or OFF.

Active Remote Control Status

```
UNIT ACTIVE REMOTE CONTROL = XXXXXX
```

This message indicates whether the system was operating under Active Remote Control (RCC, ISN, LOAD, TEMP, or SOUND) or standard control (NONE) at the time of the fault.

```
UNIT SOUND LIMIT  LOCAL = XXX %
              ISN = XXX  REMOTE = XXX %
```

This message indicates that sound limiting was in effect, the amount, and whether it was local or remotely limited.

VSD Data**VSD Actual and Command Frequency**

```
VSD FREQUENCY  ACTUAL = XXX.X Hz
              COMMAND = XXX.X Hz
```

This message indicates the VSD actual operating frequency and the command frequency at the time of the fault. Actual and command may not match due to load/unload timers, limitation of 1 Hz per load/unload increment, and to allowable acceleration/deceleration of the motor.

Compressor Amps and %FLA

```
COMP 1 = XXX AMPS      = XXX %FLA
COMP 2 = XXX AMPS      = XXX %FLA
```

VSD Current Limit

```
VSD CURRENT LIMIT  LOCAL = XXX %FLA
              ISN = XXX  REMOTE = XXX %FLA
```

This message displays the current limit values as set locally, by an ISN, or a remote current limiting input at the time of the fault.

DC BUS Voltage

```
VSD          DC BUS VOLTAGE = XXX VDC
```

This message displays the DC Bus voltage at the time of the fault.

VSD Internal Ambient Temp

```
VSD          INTERNAL AMBIENT TEMP = XXX.X °F
              COOLING SYSTEM STATUS = YYY
```

This message displays the VSD/Microprocessor internal ambient cabinet temperature and the cooling system status (ON or OFF) at the time of the fault.

IGBT Baseplate Temperature

VSD IGBT BASEPLATE TEMPS T1 = XXX
°F T2 = XXX

This message displays the IGBT highest baseplate temperature for 2 and 3 compressor units at the time of the fault. 4 compressor units display temperatures for 1/3 (T1) and 2/4 (T2).

Precharge Signal Status and VSD Cooling Status

VSD PRECHARGE SIGNAL = XXX

This display provides the state of the precharge signal, where XXX is either ON or OFF at the time of the fault.

Compressor #1 and #2, 105% FLA Motor Overload Current Setting

VSD COMP 1 MOTOR OVERLOAD = XXX AMPS
COMP 2 MOTOR OVERLOAD = XXX AMPS

This message displays the setting of the VSD's 100% FLA potentiometer for Compressor #1 and #2 at the time of the fault.

System Data**System #1 Pressures**

SYS 1 PRESSURES OIL = XXXX PSIG
DISCHARGE = XXXX PSIG

This message displays the measured system oil and discharge pressures at the time of the fault.

SYS 1 PRESSURES SUCTION = XXXX PSIG
CONDENSER LIQUID = XXXX PSIG

This message displays the measured system suction and condenser liquid line pressure at the time of the fault.

System # 1 Temperatures

SYS 1 TEMPERATURES OIL = XXX.X °F
EDUCTOR = XXX.X °F

This message displays the measured system oil and eductor temperatures at the time of the fault.

SYS 1 CONDENSER LIQUID TEMP = XXX.X °F
SUBCOOLING = XXX.X SAT TEMP = XXX.X °F

This message displays the condenser liquid, liquid line subcooling and saturated discharge temperatures at the time of the fault.

SYS 1 DISCHARGE TEMP = XXX.X °F
SUPERHEAT = XXX.X SAT TEMP = XXX.X °F

This message displays the system discharge, discharge superheat and saturated discharge temperatures at the time of the fault.

Compressor Speed and Heater Status

SYS 1 COMPRESSOR SPEED = XXX.X %
HEATER = XXX.X °F

This message indicates the compressor speed in % and the heater status at the time of the fault.

System #1 Motor Temperatures

SYS 1 MOTOR TEMPS T1 = XXX.X °F
T2 = XXX.X T3 = XXX.X °F

This message displays the System 1 motor thermistor temperatures at the time of the fault.

Flash Tank Level and Economizer Position

SYS 1 FLASH TANK LEVEL Y 512 ADC
ECONOMIZER VALVE =

This message displays the flash tank level and the economizer valve position in % at the time of the fault.

Condenser Subcooling and Condenser Drain valve Position

SYS 1 CONDENSER SUBCOOLING = XXX.X °F
CONDENSER DRAIN VALVE =

This message displays the condenser subcooling and the Condenser Drain Valve position at the time of the fault.

Condenser Fans

SYS 1 CONDENSER FANS ON = X

**SYS 1 CONDENSER FANS ON = X
VSD FAN SPEED XX.X v = XXX %**

This message displays the number of condenser fans ON or the optional VSD fan control speed signal to the inverter and the % of full speed.

VI Step Solenoid

**SYS 1 VI STEP SOLENOID 1 = XXX
VI STEP SOLENOID 2 = XXX**

This message displays whether the VI solenoids were ON or OFF at the time of the fault.

Compressor #1 Run Time

**SYS 1 RUN TIME
XX DAYS XX HOURS XX MINUTES XX SECONDS**

This message displays the system run time since the last start in days, hours, minutes, and seconds at the time of the fault.

System #1 Run Signals

**SYS 1 RUN SIGNALS RELAY = XXX
RUN PERM = XXX SOFTWARE = XXX**

This message displays the System Run Signal Relay (Relay Output Board) status, Run Permissive Input status, and the Internal Software (microprocessor command) ON/OFF Start status. The status of each will indicate either ON or OFF.

System 2 Data

Data for the system 2 at the time of the fault is displayed in the same sequence as the system #1 data.

Compressor Operating Hours and Starts

**HOURS 1=XXXXX, 2=XXXXX
START 1=XXXXX, 2=XXXXX**

This message displays compressor operating hours and compressor starts at the time of the fault.

Chilled Liquid Setpoint Cooling Setpoints

**SETPOINTS
LOCAL COOLING SETPOINT = XXX.X °F**

This message displays the programmed cooling setpoint at the time of the fault.

**SETPOINTS
LOCAL CONTROL RANGE = +/- X.X °F**

This message displays the programmed Control Range at the time of the fault.

Remote Setpoint and Range

**SETPOINTS REMOTE SETPOINT = XXX.X °F
REMOTE CONTROL RANGE = +/- X.X °F**

This message displays the remote setpoint and Control Range at the time of the fault.

Maximum Remote Temperature Setpoint

**SETPOINTS
MAXIMUM REMOTE TEMP RESET = XXX.X °F**

This message displays the maximum remote reset programmed at the time of the fault.

Options

8

Display Language

**OPTIONS DISPLAY LANGUAGE
◀ ▶ XXXXXXXXXXXXXXXXXXXXXXXX**

This message displays the language selected at the time of the fault.

Chilled Liquid Cooling Mode

**OPTIONS CHILLED LIQUID COOLING MODE
◀ ▶ WATER COOLING**

This message displays the chilled liquid temperature mode (water or glycol) selected at the time of the fault.

Local / Remote Control Mode

**OPTIONS CHILLED LIQUID COOLING MODE
◀ ▶ GLYCOL COOLING**

This message indicates whether Local or Remote Control Mode was selected at the time of the fault.

**OPTIONS LOCAL / REMOTE CONTROL MODE
◀ ▶ XXXXXXXXXXXXXXXXXXXXXXXX**

When Remote Control Mode is selected, control of the Chilled Liquid Setpoint is from a remote device such as an ISN/BAS controller.

Display Units Mode

```
OPTIONS  DISPLAY UNITS
◀▶      XXXXXXXXXXXXXXXXXXXXXXXX
```

This message indicates whether SI (°C, barg) or Imperial units (°F, PSIG) was selected at the time of the fault.

System Lead/Lag Control Mode

```
OPTIONS  LEAD / LAG CONTROL MODE
◀▶      XXXXXXXXXXXXXXXXXXXXXXXX
```

This message indicates the type of lead lag control selected at the time of the fault. Three choices are available:

- Automatic
- Sys 1 Lead
- Sys 2 Lead

The default mode will be AUTOMATIC.

Remote Temperature Reset

```
OPTIONS  REMOTE TEMP RESET INPUT
◀▶      XXXXXXXX
```

This message indicates whether temperature reset was active or disabled at the chiller keypad at the time of the fault and if active, the type of reset signal selected.

If the option is not factory enabled, the option will not appear.

Remote Current Reset

```
OPTIONS  REMOTE CURRENT LIMIT INPUT
◀▶      XXXXXXXXXXXX
```

This message indicates whether remote current reset was active or disabled at the chiller keypad at the time of the fault and if active, the type of reset signal selected.

If the option is not factory enabled, the option will not appear.

Remote Sound Limit Selection

```
OPTIONS  REMOTE SOUND LIMIT INPUT
◀▶      XXXXXXXXXXXX
```

This message indicates whether remote sound limit was active or disabled at the chiller keypad at the time of the fault and if active, the type of reset signal selected.

If the option is not factory enabled, the option will not appear.

Program values

Suction Pressure Cutout

```
PROGRAM
SUCTION PRESSURE CUTOUT = XXX.X PSIG
```

This message indicates the suction pressure cutout programmed at the time of the fault.

Low Ambient Cutout

```
PROGRAM
LOW AMBIENT TEMP CUTOUT = XXX.X °F
```

This message displays the low ambient temp cutout programmed at the time of the fault.

Low Leaving Chilled Liquid Temp Cutout

```
PROGRAM
LEAVING LIQUID TEMP CUTOUT = XXX.X °F
```

This message displays the low leaving chilled liquid temperature cutout programmed at the time of the fault.

Motor Current Limit

```
PROGRAM
MOTOR CURRENT LIMIT = XXX %FLA
```

This message indicates the motor current limit programmed at the time of the fault.

Pulldown Current Limit

```
PROGRAM
PULLDOWN CURRENT LIMIT = XXX %FLA
```

This message indicates the pulldown current limit programmed at the time of the fault.

Pulldown Current Limit Time

```
PROGRAM
PULLDOWN CURRENT LIMIT TIME = XXX MIN
```

This message indicates the pulldown current limit time programmed at the time of the fault.

Condenser Subcooling Setpoint

```
PROGRAM
SUBCOOLING SETPOINT = XXX.X °F
```

This message indicates the liquid subcooling setpoint programmed at the time of the fault.

Unit ID Number

```
PROGRAM
REMOTE UNIT ID NUMBER = X
```

This indicates the unit ID # programmed at the time of the fault.

Sound Limit Setpoint

```
PROGRAM
SOUND LIMIT SETPOINT = XXX %
```

This indicates the sound limit setpoint programmed at the time of the fault, if the sound limit option is activated at the factory. If the option is not factory activated, the display will not appear.

Eductor Differential Temperature

```
PROGRAM ◀DEF XXXXX LO XXXXX HI XXXXX
EDUCTOR DIFFERENTIAL = XXX °F
```

This message indicates the programmed eductor differential temperature at the time of the fault.

Eductor Safety Time

```
PROGRAM ◀DEF XXXXX LO XXXXX HI XXXXX
EDUCTOR SAFETY TIME = XXX MIN
```

This message indicates the eductor safety time programmed at the time of the fault.

Motor Temperature Unload

```
PROGRAM ◀DEF XXXXX LO XXXXX HI XXXXX
MOTOR TEMPERATURE UNLOAD = XXX °F
```

This message indicates the motor temperature programmed at the time of the fault.

SETPOINTS KEY

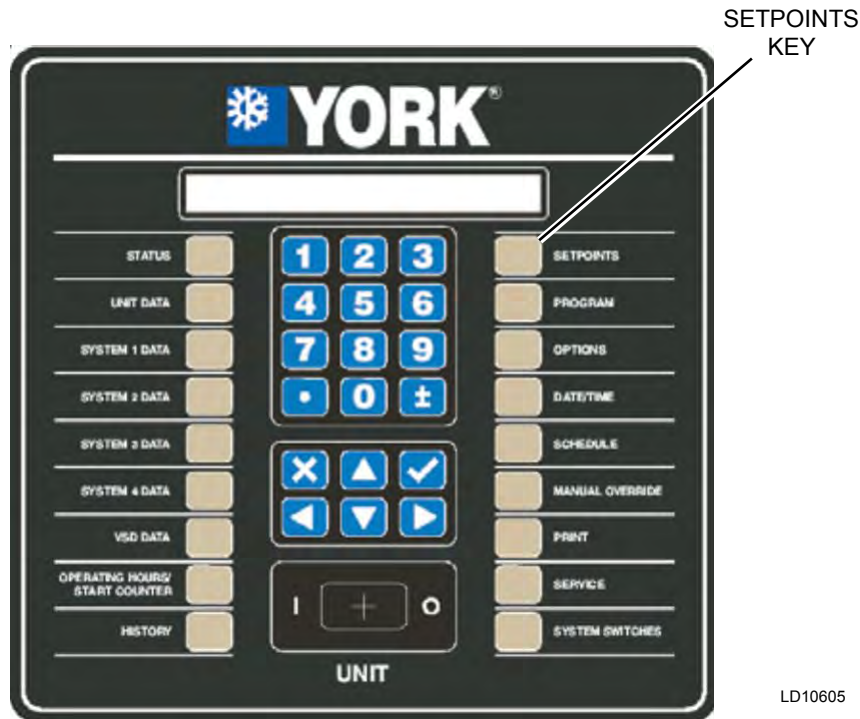

LD10605

Setpoints Key Operation

Cooling setpoints and ranges may be programmed by pressing the SETPOINTS key. The first setpoint entry screen will be displayed as shown below. The first line of the display will show the chiller default (DEF), minimum acceptable value (LO) and maximum acceptable value (HI). The second line shows the actual programmed value. Table 13 also shows the allowable ranges for the cooling setpoints and Control Ranges. Note that the Imperial units are exact values while the Metric units are only approximate.

SETPOINTS ◀DEF XXXXX LO XXXXX HI XXXXX
LOCAL COOLING SETPOINT = XXX.X °F

Pressing the SETPOINTS key a second time or the ▼ (ARROW) key will display the leaving chilled liquid Control Range, default, and low/high limits.

SETPOINTS ◀DEF XXXXX LO XXXXX HI XXXXX
LOCAL CONTROL RANGE = +/- X.X °F

Pressing the SETPOINTS key or the ▼ (ARROW) key a third time will display the remote setpoint and cooling range. This display automatically updates about every 2 seconds. This remote setpoint message is shown below:

SETPOINTS REMOTE SETPOINT = XXX.X °F
REMOTE CONTROL RANGE = +/- X.X °F

If there is no remote setpoint being utilized, the remote setpoint value will be displayed as XXXXXX and the remote Control Range will display XXX.

Pressing the SETPOINTS key or the Arrow key a fourth time will bring up a screen that allows the Maximum Remote Temperature Reset to be programmed. This message is shown below:

SETPOINTS ◀DEF XXXXX LO XXXXX HI XXXXX
MAXIMUM REMOTE TEMP RESET = XXX.X °F

The values displayed under each of the key presses may be changed by keying in new values and pressing the ✓ (ENTER) key to store the new value into memory. Where more than one value may be keyed in on a display, a portion of the data that does not need updating may be skipped by pressing the ✓ (ENTER) key. The ✓ (ENTER) key must also be pressed after the last value in the display to store the data into memory.

The ▲ (ARROW) key allows scrolling back through the setpoints displays.

The minimum, maximum, and default values allowed under the SETPOINTS key are provided in the following table.

TABLE 15- SETPOINT LIMITS

PROGRAM VALUE	MODE	LOW LIMIT	HIGH LIMIT	DEFAULT
Leaving Chilled Liquid Setpoint	Water Cooling	40.0°F	60.0°F	44.0°F
		4.4°C	15.6°C	6.7°C
	Glycol Cooling	15.0°F	70.0°F	44.0°F
		-9.4°C	15.6°C	6.7°C
Leaving Chilled Liquid Control Range	-	1.5°F	2.5°F	2.0°F
		0.8°C	1.4°C	1.1°C
Max. Remote Temperature Reset	-	2°F	40°F	20°F
		1°C	22°C	11°C

PROGRAM KEY

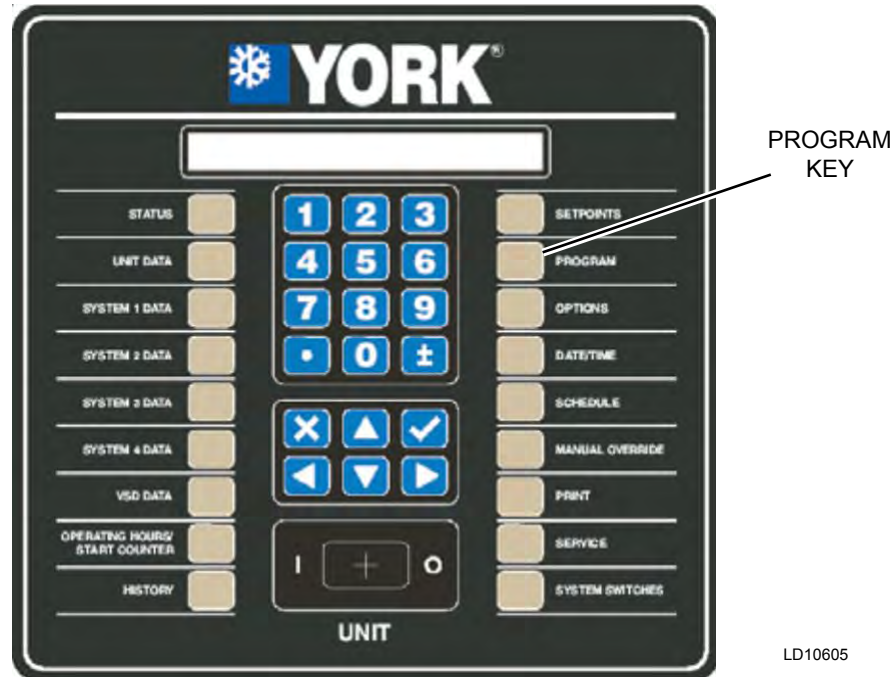

LD10605

Program Key Operation

Various operating parameters are programmable by the user. These are modified by pressing the PROGRAM key and then the ✓ (ENTER) key to enter Program Mode. A listing of the limits of the programmable values is found below. Note that the Imperial units are exact values, while Metric units are only approximate.

The ▲ and ▼ (ARROW) keys are used to scroll through the user programmable values. A value may be changed by keying in the new value and pressing the ✓ (ENTER) key to store the new value in memory. The cursor will be displayed on the screen when a number key is pressed. The first line of each message will indicate the chiller default (DEF) value, lowest acceptable programmable value (LO), and highest acceptable programmable value (HI). The user programmable value is programmed ON in the second line of the message.

When the PROGRAM key is first pressed, the following display will appear indicating the user is in the program mode:

```
PROGRAM MODE XXXX
PRESS ENTER KEY TO CONTINUE
```

Pressing the ✓ (ENTER) key again will display the first programmable selection.

Suction Pressure Cutout

```
PROGRAM ◀DEF XXXXX LO XXXXX HI XXXXX
SUCTION PRESSURE CUTOUT = XXX.X PSIG
```

The suction pressure cutout protects the chiller from a low refrigerant condition. It also helps protect from a freeze-up due to low or no chilled liquid flow. However, it is only a back-up for a flow switch and cannot protect against an evaporator freeze under many conditions. This cutout is programmable and should generally be programmed for 1.65 barg (24 PSIG) for chilled water cooling.

The cutout is programmable between 1.65 and 2.48 barg (24.0 and 36.0 PSIG) in the Water Cooling mode and 0.34 and 2.28 barg (5.0 and 36.0 PSIG) in the Glycol Cooling mode. The default value for both modes will be 1.65 barg (24.0 PSIG).

Low Ambient Cutout

```
PROGRAM ◀DEF XXXXX LO XXXXX HI XXXXX
LOW AMBIENT TEMP CUTOUT = XXX.X °F
```

The low ambient temp cutout allows programming the outdoor temperature at which it is desired to shut down the chiller to utilize other methods of cooling.

The cutout is programmable between -18.9°C (-2.0°F) and 10.0°C (50°F) with a -3.9°C (25°F) default.

Low Leaving Liquid Temp Cutout

```
PROGRAM <DEF XXXXX LO XXXXX HI XXXXX
LEAVING LIQUID TEMP CUTOUT = XXX.X °F
```

The leaving chilled liquid temp cutout is programmed to avoid freezing the evaporator due to excessively low chilled liquid temperatures. The cutout is automatically set at 2.2 °C (36°F) in the Water Cooling mode and is programmable in the Glycol Cooling mode. In the Glycol Cooling Mode, the cutout is programmable from -11.7°C to 2.2°C (11.0°F to 36.0°F) with a default of 2.2°C (36.0°F).

Motor Current Limit

```
PROGRAM <DEF XXXXX LO XXXXX HI XXXXX
MOTOR CURRENT LIMIT = XXX % FLA
```

The motor current limit %FLA is programmable. This allows the microprocessor to limit a system before it faults on high current. Typically, the limit point is set at 100%. The unload point is programmable from 30 to 100% with a default of 100%.

Pulldown Current Limit

```
PROGRAM <DEF XXXXX LO XXXXX HI XXXXX
PULLDOWN CURRENT LIMIT = XXX % FLA
```

The pulldown current limit %FLA is programmable. This allows the microprocessor to limit a system on pulldown limiting for the purpose of peak time energy savings. Typically, the limit point is set at 100%. The pulldown limit point is programmable from 30 to 100% with a default of 100%. Be aware when using pulldown motor current limit, the chiller may not be able to load to satisfy temperature demand

Pulldown Current Limit Time

```
PROGRAM <DEF XXXXX LO XXXXX HI XXXXX
PULLDOWN CURRENT LIMIT TIME = XXX MIN
```

The pulldown current limit time is programmable. This allows the microprocessor to limit a system on pulldown limiting for a defined period of time for the purpose of peak time energy savings. The pulldown limit point is programmable from 0 to 255 with a default of 0 Min.

Subcooling Setpoint

```
PROGRAM <DEF XXXXX LO XXXXX HI XXXXX
SUBCOOLING SETPOINT = XXX.X °F
```

The liquid subcooling superheat setpoint is programmable from 0.0 to 11.1°C (0.0 to 20.0°F) with a 2.8°C (5.0°F) default. Typically the subcooling control will be programmed for 2.8°C (5.0 °F).

Unit ID Number

```
PROGRAM <DEF XXXXX LO XXXXX HI XXXXX
REMOTE UNIT ID NUMBER = X
```

For purposes of remote communications, multiple chillers may be connected to an RS-485 communications bus. To allow communications to each chiller, a chiller ID number may be programmed into memory. On a single chiller application, the value will be "0".

Sound Limit Setpoint

```
PROGRAM <DEF XXXXX LO XXXXX HI XXXXX
SOUND LIMIT SETPOINT = XXX %
```

The sound limit setpoint is programmable from 0 to 100 % with a 0% default. 0% allows operating up to the full speed capability of the unit with no sound limiting. Typically the sound limit control setting will be programmed for 0 % unless sound limiting is utilized on the chiller. Sound limiting will only permit the unit to run to a frequency less than the maximum speed capability of the unit. Programming a value of 1% would be the minimum sound limiting that can be programmed and 100% will be the maximum. 100% will only allow the unit speed to operate at the minimum frequency. Usually, the sound limit % will be programmed somewhere between 0 and 100% according to the limiting needed to satisfy the sound requirements of the site. Typically, sound limiting will be utilized in areas sensitive to noise during night-time hours. The sound limit display will only be present if the sound limit option is programmed at the factory.

8

Eductor Differential

PROGRAM ◀DEF XXXXX LO XXXXX HI XXXXX
EDUCTOR DIFFERENTIAL = XXX °F

The eductor temperature differential is programmable from 0°C to 10.0°C (0°F to 50.0°F). The default value is 5.0°F. The programmed temperature assures the micro will sense a loss of educator oil flow, if the temperature differential rises. A small differential of 2.8°C (5.0°F) is recommended.

Eductor Safety Time

PROGRAM ◀DEF XXXXX LO XXXXX HI XXXXX
EDUCTOR SAFETY TIME = XXXX MIN

The educator safety time allows programming the time period the system is permitted to run if the safety threshold is exceeded. The safety time is programmable for 10 minutes to 1000 minutes with 10 minutes as the default. A minimum safety time is recommended to assure the compressor is not starved for oil for long periods of time due to the educator circuit not siphoning oil from the evaporator. A minimum time of 10 minutes is recommended as the program point.

Motor Temperature Unload

PROGRAM ◀DEF XXXXX LO XXXXX HI XXXXX
MOTOR TEMPERATURE UNLOAD = XXX °F

The motor temperature unload is programmable from 65.6°C (150.0°F) to 121.1°C 250.0°F. The default value is 115.5°C (240.0°F). The programmed temperature assures the micro will sense a rise in motor temperature due to a lack of compressor cooling. If the temperature rises above the programmed threshold, the system will unload the compressor by reducing speed. An unload temperature of 115.5°C (240.0°F) is recommended to assure the system does provides maximum capacity.

Default values

A listing of the low limits, high limits, and default values for each of the programmable values is noted in each display and can be found in Table 16. Note that the Imperial units are exact values while the Metric units are only approximate.

TABLE 16- PROGRAMMABLE OPERATING PARAMETERS

PROGRAM VALUE	MODE	LOW LIMIT	HIGH LIMIT	DEFAULT
Suction Pressure Cutout	Water Cooling	24.0 PSIG	36.0 PSIG	24.0 PSIG
		1.65 barg	2.48 barg	1.65 barg
	Glycol Cooling	5.0 PSIG	36.0 PSIG	24.0 PSIG
		0.34 barg	2.48 barg	1.65 barg
Low Ambient Temp. Cutout	-	-2.0°F	50.0°F	25.0°F
		-18.9°C	10.0°C	-3.9°C
Leaving Chilled Liquid Temp. Cutout	Water Cooling	-	-	36.0°F
		-	-	2.2°C
	Glycol Cooling	11.0°F	36.0°F	36.0°F
		-11.7°C	2.2°C	2.2°C
motor Current Limit	-	30% FLA	103% FLA	103% FLA
Pulldown motor Current Limit	-	30% FLA	100% FLA	100% FLA
Pulldown motor Current Limit Time	-	0 min	255 min	0 min
Condenser Subcooling Setpoint	-	0.0°F	20.0°F	5.0°F
		0.0°C	11.1°C	2.8°C
Unit ID Number	-	0	7	0
Sound Limit Setpoint	Sound Limit option Enabled	0%	100%	0%
Eductor Temp Differential	-	5.0°F	50.0°F	5.0°F
		-15.0°C	10.0°C	-15.0°C
Eductor Safety Time	-	10 min	1000 min	10 min
Motor Temperature Unload	-	150.0°F	250.0°F	240.0°F
		65.6°C	121.1°C	115.5°C

OPTIONS KEY

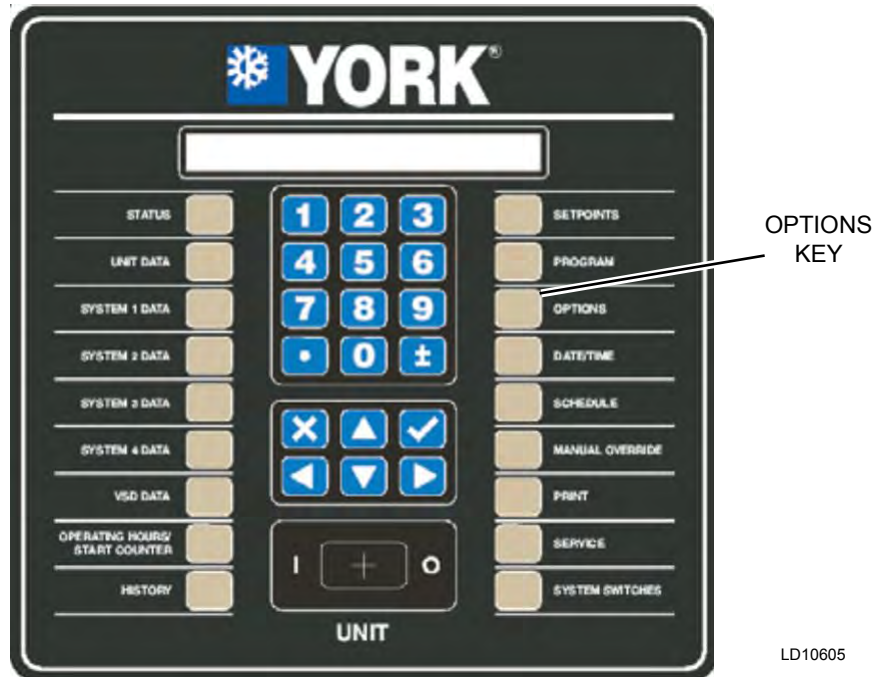

OPTIONS KEY

LD10605

Options Key Operation

The OPTIONS key provides the user with a display of unit configuration and the capability to modify the configuration. These options can only be viewed under the OPTIONS key. To view the current options settings, press the OPTIONS key. Each press of the OPTIONS key or press of the ▲ or ▼ (ARROW) keys will scroll to the next option setting. The ◀ and ▶ (ARROW) keys allow changing the option choices. The ✓ (ENTER) key must be pressed after a selection is made to save the change in memory.

An explanation of each option message is provided below.

Display Language Selection

The display language can be selected for English, Italian, Polish, Hungarian, German, French, Portuguese, and Spanish.



The default language will be English.

Chilled Liquid Cooling Mode Selection

The Chilled liquid cooling mode can be selected for Water Cooling or low temperature Glycol Cooling.



When Water Cooling is chosen, the chilled liquid temperature setpoint can only be programmed from 4°C to 21°C (40°F to 70°F).



When Glycol Cooling is chosen, the chilled liquid temperature setpoint can be programmed from -12°C to 21°C (10°F to 70°F).



The default Chilled Liquid Mode will be WATER COOLING.

Local / Remote Control Mode Selection

Local or Remote Control Mode allows the user to select the chilled liquid temperature control mode.



When LOCAL CONTROL mode is selected, chilled liquid control is from the keypad of the chiller. In local mode, a remote device can read system data, but not reset operating parameters.

OPTIONS LOCAL / REMOTE CONTROL MODE
 ◀ ▶ **LOCAL CONTROL**

When REMOTE CONTROL mode is selected, control of the chilled liquid setpoint is from a remote device such as an ISN/BAS controller.

OPTIONS LOCAL / REMOTE CONTROL MODE
 ◀ ▶ **REMOTE CONTROL**

The default mode will be LOCAL CONTROL.

Display Units Selection

Imperial or SI display units may be selected for data display.

OPTIONS DISPLAY UNITS
 ◀ ▶ **XXXXXXXXXXXXXXXXXXXX**

The user may select system operating temperatures and pressures to be displayed in either SI (°C, barg) or Imperial units (°F, PSIG).

OPTIONS DISPLAY UNITS
 ◀ ▶ **IMPERIAL**

OPTIONS DISPLAY UNITS
 ◀ ▶ **SI**

The default mode is IMPERIAL.

System Lead/Lag Control Mode Selection

The operator may select the type of lead/lag control desired.

OPTIONS LEAD / LAG CONTROL MODE
 ◀ ▶ **XXXXXXXXXXXXXXXXXXXX**

In most cases, automatic lead/lag will be selected. When automatic lead/lag is selected, the microprocessor will attempt to balance run time by switching the lead compressor whenever all compressors are shut OFF. If a compressor is not able to run when the microprocessor attempts a start, the microprocessor will select another compressor in an effort to control chilled liquid temperature. Manual lead/lag allows selecting a specific compressor to be the lead.

OPTIONS LEAD / LAG CONTROL MODE
 ◀ ▶ **AUTOMATIC**

The default mode will be AUTOMATIC.

Lag selections of individual systems will appear as:

OPTIONS LEAD / LAG CONTROL MODE
 ◀ ▶ **MANUAL SYS 1 LEAD**

OPTIONS LEAD / LAG CONTROL MODE
 ◀ ▶ **MANUAL SYS 2 LEAD**

Remote Temperature Reset Selection

Remote temperature reset from an external source may be tied directly into the chiller microprocessor board.

OPTIONS REMOTE TEMP RESET INPUT
 ◀ ▶ **XXXXXXXXXXXXXXXXXXXX**

Selections may be made for DISABLED (no signal), 0 to 10VDC, 2 to 10VDC, 0 to 20ma, and 4 to 20ma.

OPTIONS REMOTE TEMP RESET INPUT
 ◀ ▶ **DISABLED**

OPTIONS REMOTE TEMP RESET INPUT
 ◀ ▶ **0.0 TO 10.0 VOLTS DC**

OPTIONS REMOTE TEMP RESET INPUT
 ◀ ▶ **2.0 TO 10.0 VOLTS DC**

OPTIONS REMOTE TEMP RESET INPUT
 ◀ ▶ **0.0 TO 20.0 MILLIAMPS**

OPTIONS REMOTE TEMP RESET INPUT
 ◀ ▶ **4.0 TO 20.0 MILLIAMPS**

The default setting for Remote Temp Reset is DISABLED. This display will only appear if the remote temperature limit option is enabled under the Unit Setup Mode.

Remote Current Limit Input Selection

Remote current limit from an external source may be tied directly into the chiller microprocessor board.

OPTIONS REMOTE CURRENT LIMIT INPUT
 ◀ ▶ **XXXXXXXXXXXXXXXXXXXX**

Selections may be made for DISABLED (no signal), 0 to 10VDC, 2 to 10VDC, 0 to 20ma, and 4 to 20ma.

OPTIONS REMOTE CURRENT LIMIT INPUT
 ◀ ▶ **DISABLED**

OPTIONS REMOTE CURRENT LIMIT INPUT
 ◀ ▶ **0.0 TO 10.0 VOLTS DC**

OPTIONS REMOTE CURRENT LIMIT INPUT
◀ ▶ 2.0 TO 10 VOLTS DC

OPTIONS REMOTE CURRENT LIMIT INPUT
◀ ▶ 0.0 TO 20.0 MILLIAMPS

OPTIONS REMOTE CURRENT LIMIT INPUT
◀ ▶ 4.0 TO 20.0 MILLIAMPS

The default setting for Remote Current Reset is DISABLED. This display will only appear if the remote current limit option is enabled under the Unit Setup Mode.

Remote Sound Limit Selection

Remote sound limit from an external source may be tied directly into the chiller microprocessor board.

OPTIONS REMOTE SOUND LIMIT INPUT
◀ ▶ XXXXXXXXXXXXXXXXXXXXXXXX

Selections may be made for DISABLED (no signal), 0 to 10VDC, 2 to 10VDC, 0 to 20ma, and 4 to 20ma.

OPTIONS REMOTE SOUND LIMIT INPUT
◀ ▶ DISABLED

OPTIONS REMOTE SOUND LIMIT INPUT
◀ ▶ 0.0 TO 10.0 VOLTS DC

OPTIONS REMOTE SOUND LIMIT INPUT
◀ ▶ 2.0 TO 10.0 VOLTS DC

OPTIONS REMOTE SOUND LIMIT INPUT
◀ ▶ 0.0 TO 20.0 MILLIAMPS

OPTIONS REMOTE SOUND LIMIT INPUT
◀ ▶ 4.0 TO 20.0 MILLIAMPS

The default setting for Remote Sound Limit is DISABLED. This display will only appear if the remote sound limit option is enabled under the Unit Setup Mode.

Low Ambient Cutout Enable/Disable

The low ambient cutout may be enabled or disabled. When enabled, the chiller will cut OFF when the low ambient cutout is reached. When disabled, the chiller will run at any temperature.

OPTIONS LOW AMBIENT TEMPERATURE CUTOUT **8**
◀ ▶ ENABLED

OPTIONS LOW AMBIENT TEMPERATURE CUTOUT
◀ ▶ DISABLED

The default setting for the low ambient cutout will be ENABLED.

DATE/TIME AND SCHEDULE KEYS

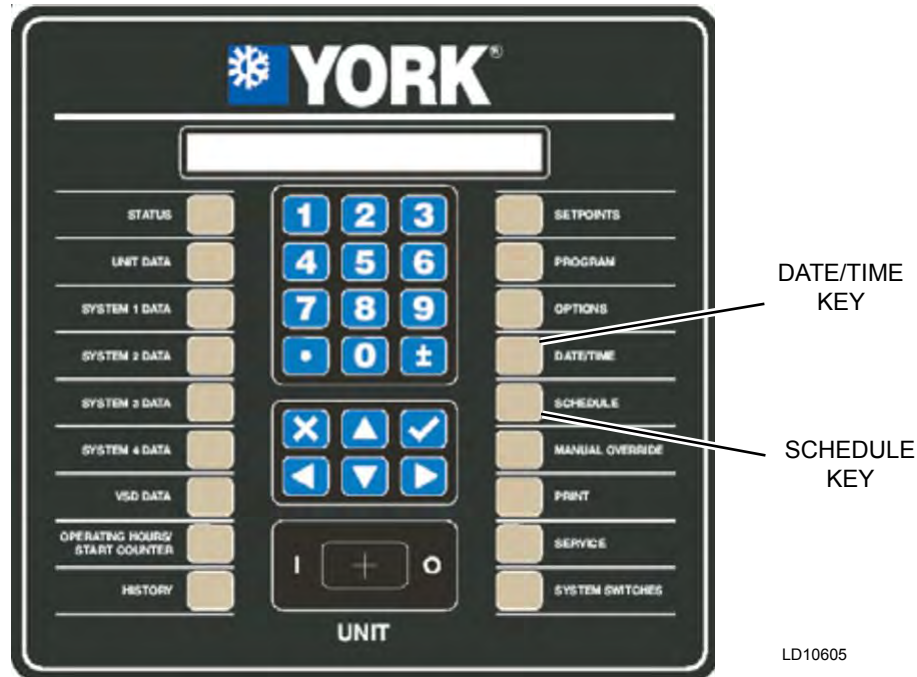

Date/Time Key Operation

When the DATE/TIME key is pressed, the chiller microprocessor will display the date and the time. This feature is useful and required for using the Daily Schedule. It is also a valuable tool for troubleshooting to allow a technician to determine the time of the fault, which is stored in the history memory buffers. When the DATE/TIME key is pressed, the first display screen shown below will be displayed:

```
CLOCK FRI 18-JUN-2011 10:15:33 AM
DAY OF WEEK ◀ ▶ = XXX
```

Whenever any changes are made, the ✓ (ENTER) key must be pressed to store the data.

Pressing the ▲ or ▼ (Arrow) keys allows scrolling to the next programmed item. Pressing the ▼ (DOWN ARROW) key scrolls to the next item that can be programmed and the ▲ (UP ARROW) key scrolls to the previous item.

The day of the week is the first display and can be changed by pressing either the ◀ or ▶ (LEFT OR RIGHT ARROW) key to select the day. After the day is selected, the ✓ (ENTER) key must be pressed to store the data.

```
CLOCK FRI 18-JUN-2011 10:15:33 AM
DAY OF MONTH = XX
```

Pressing the ▼ (DOWN ARROW) key again scrolls to the day of the month:

```
CLOCK FRI 18-JUN-2011 10:15:33 AM
DAY OF MONTH = XX
```

The day of the month can be selected by keying in the numerical value to select the day. After the day of the month is selected, the ✓ (ENTER) key must be pressed to store the data.

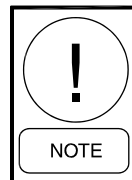

A "0" must be typed in to select dates for days of the 1st through the 9th.

Pressing the ▼ (DOWN ARROW) key again scrolls to month:

```
CLOCK FRI 18-JUN-2011 10:15:33 AM
MONTH ◀ ▶ = XXX
```

The month can be selected by scrolling through the months with the ◀ or ▶ arrow keys. After the month is selected, the ✓ (ENTER) key must be pressed to store the data.

Pressing the ▼ (DOWN ARROW) key again scrolls to the year:

CLOCK FRI 18-JUN-2011 10:15:33 AM
YEAR = XXXX

The year can be selected by keying in the numerical value to select the year. After the year is selected, the ✓ (ENTER) key must be pressed to store the data.

Pressing the ▼ (DOWN ARROW) key again scrolls to the hour:

CLOCK FRI 18-JUN-2011 10:15:33 AM
HOUR = XX

The hour can be selected by keying in the numerical value for the hour. After the hour is selected, the ✓ (ENTER) key must be pressed to store the data.

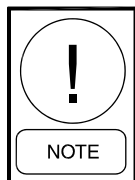

One or two "0's" must be keyed in for hours 00-09.

Pressing the ▼ (DOWN ARROW) key again scrolls to the minute:

CLOCK FRI 18-JUN-2011 10:15:33 AM
MINUTE = XX

The minute can be selected by keying in the numerical value for the hour. After the minute is selected, the ✓ (ENTER) key must be pressed to store the data.

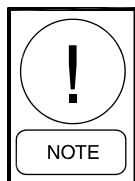

One or two "0's" must be keyed in for minutes 00 through 09.

Pressing the ▼ (DOWN ARROW) key again scrolls to AM/PM:

CLOCK FRI 18-JUN-2011 10:15:33 AM
AM/PM ◀ ▶ = XX

AM/PM can be selected by pressing the ◀ or ▶ (ARROW) keys. After the meridian is selected, the ✓ (ENTER) key must be pressed to store the data.

Pressing the ▼ (DOWN ARROW) key again scrolls to the time format selection:

CLOCK FRI 18-JUN-2011 10:15:33 AM
TIME FORMAT ◀ ▶ = XXXXXXXX

The time format may be displayed in either a 12 hour or 24 hour format. Selection can be changed by pressing the ◀ or ▶ (ARROW) keys. The ✓ (ENTER) key must be pressed to store the data.

Schedule Key Operation

The Daily Schedule must be programmed for the unit start and stop times. To set the schedule, press the SCHEDULE key. The display will provide a message allowing access to 2 types of schedule information:

SCHEDULE CHOOSE SCHEDULE TYPE
◀ ▶ XXXXXXXXXXXXXXXXXXXXXXXXXXXXXXXX

The schedule types are:

- UNIT OPERATING SCHEDULE
- (Default selection)
- SOUND LIMIT SCHEDULE
 (Only if Sound Limiting is enabled by the factory when the option is installed.)

The schedule type (UNIT OPERATING SCHEDULE or SOUND LIMIT SCHEDULE) may be changed by pressing the ◀ (LEFT ARROW) or ▶ (RIGHT ARROW) keys followed by the ✓ (ENTER) key. The selection must be entered by pressing the ✓ (ENTER) key before a schedule display will appear.

8

Unit Operating Schedule

The Unit Operating Schedule is used to enable/disable the chiller unit on time of day. The chiller can be enabled and disabled once each day or it can be programmed to run continuously. Any time the daily or holiday schedule shuts the chiller down, the running system(s) will go through a controlled ramped shutdown. If the UNIT OPERATING SCHEDULE is selected under the CHOOSE SCHEDULE display, the following message will appear:

SCHEDULE UNIT OPERATING
MON START = 06:00 AM STOP = 10:00 PM

The line under the 0 above is the cursor. If the start time is wrong, it can be changed by keying in the new time from the numeric keypad. Once the correct values for the START hour and minute are entered, press the ✓ (ENTER) key. The cursor will then move to the AM/PM selection. The meridian (AM/PM) value may be changed by the ◀ (LEFT ARROW) or ▶ (RIGHT ARROW) keys and entered by pressing ✓ (ENTER) key. Repeat this process for the STOP time. Once a schedule is entered, the schedule for the next day will appear. The start and stop time of each day may be programmed differently.

To view the schedule without making a change, simply press the SCHEDULE key until the day you wish to view appears. The ▲ (UP ARROW) key will scroll backwards to the previous screen.

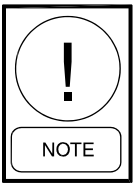

If at any time the schedule is changed for Monday, all the other days will change to the new Monday schedule. This means if the Monday times are not applicable for the whole week, then the exceptional days would need to be reprogrammed to the desired schedule.

To program the chiller for 24 hour operation, program the start and stop times of each day of the week for 00:00.

After the SUN (Sunday) schedule appears on the display, a subsequent press of the SCHEDULE or ▲ (UP ARROW) key will display the Holiday schedule. This is a two-part display. The first reads:

SCHEDULE	UNIT OPERATING
HOL	START = 00:00 AM STOP = 00:00 PM

The holiday times may be set using the same procedure as described above for the days of the week. Be sure to press the ✓ (ENTER) key after setting the START and STOP times to save the change in memory. Pressing the SCHEDULE key a second time, the display will show the individual days:

SCHEDULE	UNIT OPERATING
S M T W T F S	HOLIDAY NOTED BY *

The line below the empty space is the cursor and will move to the next or previous empty space when the ◀ (LEFT ARROW) or ▶ (RIGHT ARROW) keys are pressed. To set a day for the Holiday Schedule, the cursor must be moved to the space following the day of the week. The * key is then pressed and an "*" will appear in the space signifying that day as a holiday. The Holiday schedule must be programmed weekly. If there is no holiday, the "*" key is also used to delete the "*". The ✓ (ENTER) key is used to accept the holiday schedule for the entire week.

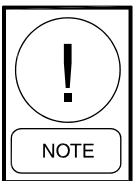

The HOLIDAY SCHEDULE is a temporary schedule. Once the schedule is executed, the selected holidays will be cleared from memory for the following week.

Sound Limit Schedule

The SOUND LIMIT SCHEDULE allows setting the day and time when the user desires using the "SILENT NIGHT" factory programmed option to limit chiller loading and fan operation for reduced audible noise in the surrounding area. If the SOUND LIMIT SCHEDULE is selected under the CHOOSE SCHEDULE display, the following message will appear:

SCHEDULE	SOUND LIMIT	= XXX %
MON	START = 06:00 AM	STOP = 10:00 PM

The Sound Limit option can be enabled and disabled once each day or the chiller can be set to run continuously in this mode for sound limiting whenever the chiller is operating. When sound limiting is enabled, the unit will be limited by the Sound Limit setpoint % as set under the PROGRAM key. XXX in the display above will show the Sound Limit Setpoint % programmed under the PROGRAM key. 0% will cause no speed reduction, while 100% only allows running at minimum speed.

The START Time for a specific day (hour and minute) is entered using the same guidelines used for the start/stop schedules, and press the ✓ (ENTER) key to store it into memory. The cursor will then move to the AM/PM selection.

The AM/PM selection may be chosen using the ◀ (LEFT ARROW) or ▶ (RIGHT ARROW) keys and pressing ✓ (ENTER) key to store the value.

This process is repeated for the STOP time.

Once the schedule for a specific day is programmed and entered, the schedule for the next day will appear. The schedule for each day may be programmed the same or differently.

To view the schedule without changing it, simply press the SCHEDULE key or the ▼ (DOWN ARROW) key until the desired day is displayed. The ▲ (UP ARROW) key will scroll backwards to the previous screen.

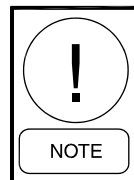

If the schedule is changed for Monday, all other days will change to the Monday schedule. Be aware of this when programming.

MANUAL OVERRIDE KEY

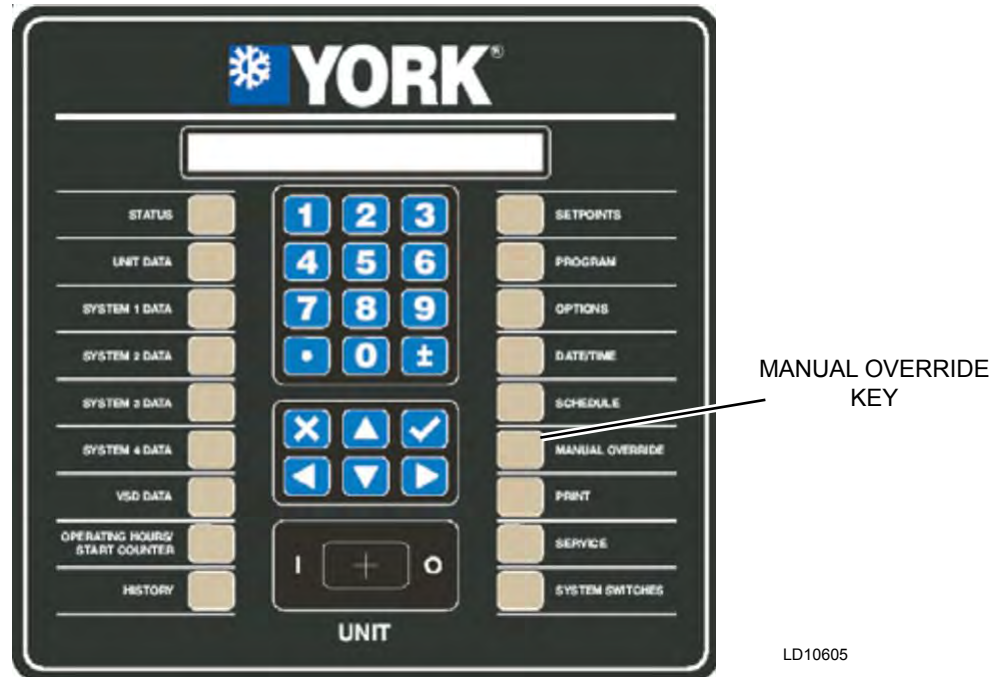

Manual Override Key Operation

If the MANUAL OVERRIDE key is pressed during a schedule shutdown, the STATUS display will display the message below. This indicates that the Daily Schedule is being ignored and the chiller will start when chilled liquid temperature allows, Remote Contacts, UNIT switch and SYSTEM switches permitting. This is a priority message and cannot be overridden

by anti-recycle messages, fault messages, etc. when in the STATUS display mode. Therefore, do not expect to see any other STATUS messages when in the MANUAL OVERRIDE mode. MANUAL OVERRIDE is to only be used in emergencies or for servicing. Manual override mode automatically disables itself after 30 minutes.

MANUAL OVERRIDE

PRINT KEY

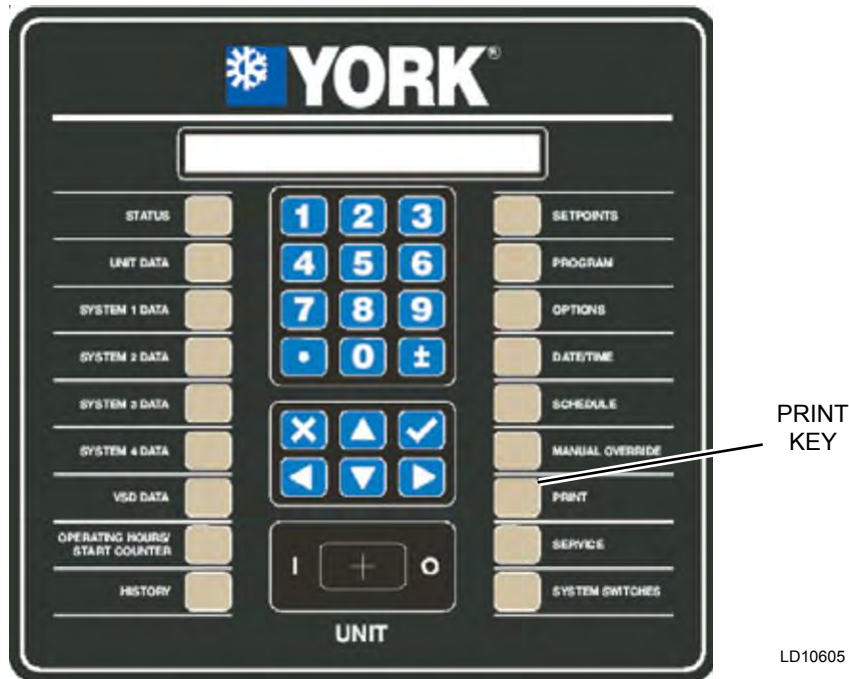

Print Key Operation

The PRINT key is used to initiate a printout of current operating data (real time data), a complete history printout of all history (fault) buffers, a printout of all normal shutdowns (compressor cycling, chiller shutdown, etc.) or history (fault) data printout of a specific fault. History Buffer 1 will always be the most recent fault history printout. Printing may also be canceled by selecting the CANCEL PRINTING option. The following message is displayed when the PRINT key is pressed.



After pressing the PRINT key, the printout type is selected by pressing the ◀ (LEFT ARROW) or ▶ (RIGHT ARROW) keys until the desired printout is displayed.

The following table shows the available printout types.

TABLE 17- PRINTOUT TYPES

PRINTOUT TYPES
operating Data (Default Selection)
All History Buffers
Normal Shutdowns
History Buffer 1
History Buffer 2
History Buffer 3
History Buffer 4
History Buffer 5
History Buffer 6
History Buffer 7
History Buffer 8
History Buffer 9
History Buffer 10
Cancel Printing

The specific printout is initiated by pressing the ✓ (ENTER) key.

A sample of the operating data printout is shown below. The operating data printout is a snapshot of current system operating conditions when the printout was selected. The sample shows combined printouts of 2, 3, and 4 circuit units. The actual printout will only show data for the appropriate chiller type.

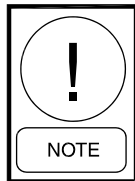

Bold italic text below a line of print is not on the actual printout. Bold italic text indicates information that may not be available on all printouts or is additional information to help explain the difference in a 2/3 or 4 circuit printout.

Operating Data Printout

```

YORK INTERNATIONAL CORPORATION
CORSAIR SCREW CHILLER
OPERATING DATA
2:04:14 PM 30 DEC 11

SYS 1
NOT RUNNING
SYS 2
COMPRESSOR RUNNING

OPTIONS
CHILLED LIQUID WATER
LOCAL/REMOTE MODE REMOTE
LEAD/LAG CONTROL AUTOMATIC
REMOTE TEMP RESET DISABLED
REMOTE CURRENT LIMIT 0 TO 10 V
REMOTE SOUND LIMIT 4 TO 20 MA
(if Sound Limiting enabled)
LOW AMBIENT CUTOUT ENABLED

PROGRAM VALUES
SUCTION PRESS CUTOUT 44 PSIG
LOW AMBIENT CUTOUT 25.0 DEGF
LEAVING LIQUID CUTOUT 36.0 DEGF
MOTOR CURRENT LIMIT 100 %FLA
PULLDOWN CURRENT LIMIT 100 %FLA
PULLDOWN LIMIT TIME 0 MIN
SUBCOOLING SETPOINT 12.0 DEGF
UNIT ID NUMBER 0
SOUND LIMIT SETPOINT 100%
(if Sound Limiting enabled)
    
```

```

UNIT DATA
LEAVING LIQUID TEMP 49.0 DEGF
RETURN LIQUID TEMP 58.2 DEGF
TEMP RATE XXX.X DEGF/MIN
COOLING RANGE 42.0+/-2.0 DEGF
REMOTE SETPOINT 44.0 DEGF
AMBIENT AIR TEMP 74.8 DEGF
LEAD SYSTEM SYS 2
FLOW SWITCH ON
EVAPORATOR PUMP RUN ON
EVAPORATOR HEATER OFF
ACTIVE REMOTE CONTROL NONE
OPERATING HOURS 1=XXXXX, 2=XXXXX
START COUNTER 1=XXXXX, 2=XXXXX
SOFTWARE VERSION C.ACS.XX.00

VSD DATA
ACTUAL FREQUENCY XXX.X HZ
COMMAND FREQUENCY XXX.X HZ
DC BUS VOLTAGE XXX VDC
INTERNAL AMBIENT TEMP XXX.X DEGF
COOLING SYSTEM STATUS XXX
BASEPLATE TEMPS XXX XXX DEGF
PRECHARGE SIGNAL XXX
MOTOR OVERLOADS 1/2 XXX XXX AMPS
SOFTWARE VERSION C.VSD.XX.00
UNIT SERIAL NUMBER YYYY XXXZZZ

SYSTEM 1 DATA
COMPRESSOR STATUS OFF
RUN TIME 0- 0- 0- 0 D-H-M-S
MOTOR CURRENT 0AMPS 0 %FLA
SUCTION PRESSURE 125 PSIG
DISCHARGE PRESSURE 131 PSIG
OIL PRESSURE 130 PSIG
CONDENSER LIQUID TEMP 68.4 DEGF
DISCHARGE TEMPERATURE 68.8 DEGF
OIL TEMPERATURE 68.8 DEGF
SAT SUCTION TEMP 71.8 DEGF
SUBCOOLING 3.4 DEGF
SAT DISCHARGE TEMP 74.5 DEGF
DISCHARGE SUPERHEAT 6.3 DEGF
MOTOR TMP XXX.XXXX.XXXX.XDEGF
COMPRESSOR SPEED XXX.X %
FLASH TANK LEVEL > 512 ADC
    
```



```

COND DRAIN % OPEN          XXX.X %
ECONOMIZER % OPEN         XXX.X %
CONDENSER FANS ON          0
CONDENSER FAN SPEED        XXX % (VSD)
COMPRESSOR HEATER          ON
VI STEP SOLENOID 1         OFF
VI STEP SOLENOID 2         OFF
RUN PERMISSIVE             ON
VSD RUN RELAY              OFF
VSD SOFTWARE RUN SIGNAL    OFF
    
```

SYSTEM 2 DATA

```

COMPRESSOR STATUS          ON
RUN TIME                   0-0-15-26 D-H-M-S
MOTOR CURRENT              104 AMPS 87 %FLA
SUCTION PRESSURE           57 PSIG
DISCHARGE PRESSURE         233 PSIG
OIL PRESSURE                218 PSIG
CONDENSER LIQUID TEMP      42.9 DEGF
DISCHARGE TEMPERATURE     145.5 DEGF
OIL TEMPERATURE            102.8 DEGF
SAT CONDENSER TEMP         31.7 DEGF
SUBCOOLING                  11.2 DEGF
SAT DISCHARGE TEMP         112.1 DEGF
DISCHARGE SUPERHEAT        33.4 DEGF
MOTOR TMP                   XXX.X XXX.X XXX.X DEGF
COMPRESSOR SPEED           XXX.X%
FLASH TANK LEVEL           < 512 ADC
COND DRAIN % OPEN          XXX.X%
ECONOMIZER % OPEN         XXX.X%
CONDENSER FANS ON          3
CONDENSER FAN SPEED        XXX% (vsd)
COMPRESSOR HEATER          OFF
VI STEP SOLENOID 1         OFF
VI STEP SOLENOID 2         OFF
RUN PERMISSIVE             ON
VSD RUN RELAY              OFF
VSD SOFTWARE RUN SIGNAL    OFF
    
```

UNIT OPERATING SCHEDULE

```

S M T W T F S             *=HOLIDAY
MON START=00:00AM         STOP=00:00AM
TUE START=00:00AM         STOP=00:00AM
    
```

```

WED START=00:00AM         STOP=00:00AM
THU START=00:00AM         STOP=00:00AM
FRI START=00:00AM         STOP=00:00AM
SAT START=00:00AM         STOP=00:00AM
HOL START=00:00AM         STOP=00:00AM
    
```

SOUND LIMIT SCHEDULE

(if enabled)

```

MON START=00:00AM         STOP=00:00AM
TUE START=00:00AM         STOP=00:00AM
WED START=00:00AM         STOP=00:00AM
THU START=00:00AM         STOP=00:00AM
FRI START=00:00AM         STOP=00:00AM
SAT START=00:00AM         STOP=00:00AM
HOL START=00:00AM         STOP=00:00AM
    
```

History Data Printout

History printouts, when selected, provide stored data relating to all specific system and chiller operating conditions at the time of the fault, regardless of whether a lockout occurred. History information is stored in battery-backed memory on the Chiller Control Board and is not affected by power failures or resetting of faults. Whenever a fault of any type occurs, all system operating data is stored in battery-backed memory at the instant of the fault. The history printout is similar to the operating data printout except for the change in the header information shown below:

YORK INTERNATIONAL CORPORATION
 CORSAIR SCREW CHILLER HISTORY

NUMBER 1

2:04:14 PM 30 APR 11

```

SYS 1 YYYYYYY
HIGH DSCH PRESS SHUTDOWN
STATUS AT TIME OF SHUTDOWN
SYS 1 XXXXXXXXXXXXXXXXXXXXXXXXXXXXXXXX
SYS 2 XXXXXXXXXXXXXXXXXXXXXXXXXXXXXXXX
    
```

ALL FAULTS

```

XXXXXXXXXXXXXXXXXXXXXXXXXXXXXXXXXXXXX
XXXXXXXXXXXXXXXXXXXXXXXXXXXXXXXXXXXXX
    
```

The most recent fault will always be stored as HISTORY BUFFER #1.

SYSTEM SWITCHES KEY



SYSTEM SWITCHES KEY

LD10605

System Switches Key Operation

The SYSTEM SWITCHES key allows the operator to turn individual systems ON and OFF. Safety lockouts are also reset by selecting the respective system switch RESET. When the SYSTEM SWITCHES key is pressed, the following message will appear:

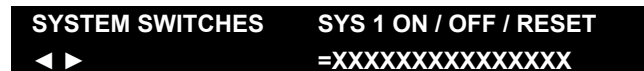

The display indicates the respective system and it's ON/OFF /reset switch status. The ▲▼ (ARROW) keys allow scrolling to the next and previous system switch (System 1 and 2).

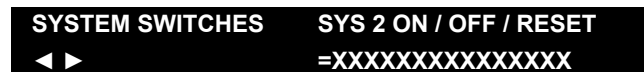

The ◀ (LEFT ARROW) or ▶ (RIGHT ARROW) keys allow scrolling through the choices of:

- SYSTEM OFF (default)
- SYSTEM ON
- RESET (LOCKOUT)

The switch selection is accepted into memory by pressing the ✓ (ENTER) key.

When the "RESET" selection is made and accepted, it will not change the position of the switch (either ON or OFF).

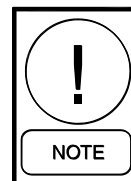

Whenever possible, except in emergencies, always use the associated system switch to turn off a compressor, which allows the compressors to go through a controlled shutdown. Avoid using the "UNIT" switch to turn off the compressors.

SECTION 9 - MAINTENANCE

GENERAL REQUIREMENTS

The units have been designed to operate continuously, provided they are regularly maintained and operated within the limitations given in this manual. Each unit should be included in a routine schedule of daily maintenance checks by the operator/customer, backed up by regular service inspection and maintenance visits by a suitably qualified Service Engineer.

It is entirely the responsibility of the owner to provide for these regular maintenance requirements and/or enter into a maintenance agreement with a Johnson Controls service organization to protect the operation of the unit. If damage or a system failure occurs due to improper maintenance during the warranty period, Johnson Controls shall not be liable for costs incurred to return the unit to satisfactory condition.

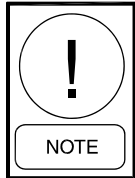

This “Maintenance” section applies to the basic unit only and may, on individual contracts, be supplemented by additional requirements to cover any modifications or ancillary equipment as applicable.



The “Safety” section of this manual should be read carefully before attempting any maintenance operations on the unit.

Weekly Maintenance

The following maintenance checks should be carried out on a weekly basis by the operator/customer. Please note that the units are not generally user serviceable and no attempt should be made to rectify faults or problems found during daily checks unless competent and equipped to do so. If in any doubt, contact your local Johnson Controls Service Agent.

Unit Status

Press the „STATUS“ key on the keypad and ensure no fault messages are displayed.

Refrigerant Leaks

Visually check the heat exchangers, compressors and pipework for damage and gas leaks.

Operating Conditions

Read the operating pressures and temperatures at the control panel using the display keys and check that these are within the operating limitations given in the manual.

Compressor Oil Level

Check each system oil level after the compressor has been operating at “Full Load” for approximately 15 to 30 minutes. The oil level should be between the bottom of the upper sight glass and the mid position of the lower sight glass on the oil separator.

Refrigerant Charge

Assure there is a level of refrigerant in the evaporator sight glass while running at “Full Load” for 15 minutes.

Adding Charge to a System

A sight glass is located in the evaporator. When optimally charged after running full load, the refrigerant level should be approximately in the center of the sight glass. There should be little concern if the level is high or low in the glass, it should not affect operation.

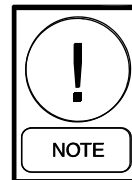

It is not necessary to weigh charge unless the entire charge has been lost. The ease of charging is possible since the microchannel coils hold only a small amount of refrigerant charge. A charging valve, located between the fixed orifice and the evaporator, may be used if charge adjustment is required. Charge should be added as liquid. If the complete charge needs to be added, see Refrigerant Removal, Evacuation and Charging a YVAA Chiller on Page 108 in this section. Use the valve on the liquid line for adding the full charge and open the valves per the procedure.

REFRIGERANT REMOVAL, EVACUATION AND CHARGING A YVAA CHILLER

Refrigerant Removal

The YVAA utilizes a flooded evaporator. Extreme care must be taken when removing refrigerant to prevent damage to the evaporator and the chiller. Carefully review the following caution below before proceeding with the recommended process.



Incorrect removal of refrigerant will result in catastrophic freeze damage to the evaporator and possible additional damage to other chiller components. Whenever there is water in the evaporator, the chilled liquid pumps must be ON and circulating liquid through the evaporator above minimum recommended flow rates. When liquid refrigerant is being removed, monitor the pressure and do not allow the pressure to drop below the freeze point of the chilled liquid flowing through the evaporator until all liquid refrigerant has been removed from the evaporator and only gas remains. Once all liquid has been removed, the remaining refrigerant vapor can be removed while allowing the pressure to drop below the freeze point with the pump circulating liquid through the evaporator.

To remove refrigerant from the evaporator, follow the procedure below:

1. Turn the chilled liquid pump ON and assure the flow is above the minimum recommended flow.
2. Assure all manual valves in the system are open. Open Condenser Drain and Economizer Feed valves to 100% in the service mode.
3. Connect the recovery unit and a manifold gauge to the liquid line feeding the eductor. There may be a valve in the line or a fitting on the eductor filter for this purpose.
4. Connect the recovery unit to a recovery cylinder sitting on a reliable scale. Turn the recovery unit ON and observe the liquid refrigerant flowing from the line into the cylinder. The flow of liquid should be obvious.

5. Monitor the pressure gauge to assure that the pressure does not drop below the freeze point of the chilled liquid. Throttle the flow as needed with the manifold gauge valves to prevent pressures from dropping below the freeze point.
6. Continue to remove the liquid refrigerant while observing the flow and the pressure. Note the charge in the system based on the nameplate data to determine when the charge removal is nearly complete. Monitor the weight of the recovery cylinder to determine when the cylinder is full. Change the cylinder as needed.
7. Continue removing refrigerant until liquid is no longer observed flowing in the manifold hoses.
8. Once the liquid is removed and no longer visible in the hose, the remaining gas can be pumped out with the recovery unit while the pressure is allowed to drop to 0 barg (0 PSIG).
9. Servicing may now be performed on the system as needed.

Evacuating a System

To evacuate a system, follow the procedure below:

1. Turn the chilled liquid pump ON and assure the flow is above the minimum recommended flow.
2. Assure all manual valves are open. Open the Condenser Drain (Flash Tank Feed) and Economizer Valves in the Service Mode to 100 %
3. Connect vacuum hoses to as many points as possible. Be sure that at least one connection is made on both the high and low side of the piping. A connection to the evacuation fitting on the compressor is also recommended. Evacuate the system to a minimum of 500 microns. Close the valves at the evacuation points and assure the pressure in the chiller does not rise more than 50 microns in 10 minutes. Check for leaks if the pressure rises.

Charging Refrigerant into a System

To charge the system with refrigerant, follow the procedure below:

1. With all system valves open and the Condenser Drain and Economizer Valves open to 100% by manually opening them in the Service Mode,

charge refrigerant vapor into the high side of the system at the charging port on the liquid line. Continue charging vapor until the pressure is above the freeze point of the chilled liquid. Once above the freeze point, liquid can be charged according to the recommended nameplate charge.

2. Reconnect the water piping to the water boxes.
3. Close the evaporator drain valves and fill the evaporator with water from the cooling loop.
4. Fill the water loop and check for leaks.
5. Close (0%) the Condenser Drain and Economizer Valve in the Service Mode. Recycle the chiller power.
6. Once the system is operating, the charge will distribute itself throughout the system. Trim the charge as needed to a level of about midway on the evaporator sight glass while running full speed for 15 minutes.

MICROCHANNEL COIL CLEANING

The coil cleaning procedure for microchannel coils is significantly different than tube and fin type coils. As such, care must be taken to understand the differences to avoid damage to the microchannel coil. These differences require a number of DO NOT's that must be observed:

- DO NOT use coil cleaners or any chemical on a microchannel coil. This can cause severe damage to the coils.
- DO NOT use a pressure washer to clean the coils. While it is possible to clean a coil with a pressure washer, it's also possible to destroy it.
- DO NOT contact the coil with a hard surface such as a hose nozzle or metal vacuum nozzle or any other tool.

Microchannel coils tend to accumulate more dirt on the surface, but less dirt inside the coils, which makes them easier to clean. Follow the three steps below for cleaning the coils:

1. Remove surface debris such as dirt, leaves, insects, fibers, etc. with a vacuum cleaner having a soft attachment rather than a metal tube. Compressed air blown from the inside out can also be used. When brushing debris off the face of the coil a soft bristle (not wire) brush can be used. Do not scrape the coil with the vacuum nozzle, air nozzle, or any other tool.
2. Rinse the coil with tap water. Do not use coil cleaners. Rinse the coil from the inside out, running water through every passage in the heat exchanger surface until it is clean. Microchannel coils are stronger than conventional tube and fin coils, but handle them with care, since you can cause a leak due to impact. Use a gentle spray from a spray nozzle with a plastic end or put your finger on the end of the spray nozzle to reduce impact and provide a gentle spray.
3. Because of the fin geometry, microchannel coils retain water more than tube and fin style. It is generally recommended to blow or vacuum out the rinse water from the coils to speed drying and prevent water pooling.

Scheduled Maintenance

The maintenance operations detailed in the following table should be carried out on a regular basis by a suitably qualified Service Engineer. It should be noted that the interval necessary between each „minor“ and „major“ service can vary depending on, for instance, application, site conditions and expected operating schedule. Normally a „minor“ service should be carried out every three to six months and a „major“ service once a year. It is recommended that your local Johnson Controls Service Center is contacted for recommendations for individual sites.

MAINTENANCE REQUIREMENTS FOR YVAA CHILLERS



BY JOHNSON CONTROLS PROCEDURE	WEEKLY	QUARTERLY	SEMI- ANNUALLY	ANNUALLY	EVERY 5 YEARS	EVERY * HOURS
Check oil Level in oil Separator Sight Glass.	x					
Check Liquid Line Sight Glass/ moisture Indicator.	x					
Check refrigerant level in the Evaporator Sight Glass while running full load for 10 to 15 minutes.	x					
Record System Operating Temperatures & Pressures.	x					
Check Condenser Coils for dirt / debris and clean as necessary.	x					
Check Programmable operating Setpoints and Safety Cutouts. Assure they are correct for the application.		x				
Check Compressor and Evaporator Heater operation.		x				
Check for dirt in the Panel. Check Door Gasket sealing integrity.		x				
**Leak check the Chiller.			x			
**Sample Compressor oil, check for Acid, and replace if necessary.				x		
**Disconnect Power Source and Lock out. Check tightness of Power Wiring connections.				x		
Check Glycol concentration on Low Temp. or other applications where freezing may be a problem.				x		
VSD Glycol Change.				x		

* reserved for customer use for any special site requirements.

**This procedure must be performed at the specific time by an industry certified technician who has been trained and qualified to work on this type of equipment. A record of this procedure be successfully carried out should be maintained on file by the equipment owner should proof of adequate maintenance be required at a later date for warranty purposes.

TABLE 18- TROUBLESHOOTING GUIDE

PROBLEM	POSSIBLE CAUSE	ACTION	
NO DISPLAY ON CONTROL PANEL. UNIT WILL NOT RUN.	Supply to the Panel is missing.	High Voltage to the Chiller is missing. Check 1FU, 2FU, 4FU, 5FU 17FU, or 19FU. Check 2T or 10T Transformer.	
	Line Fuse is blown.	Check Fuses.	
	Chiller Control Board is defective.	Replace Chiller Control Board.	
	Display Board defective.	Replace Display Board.	
	LINE FUSE BLOWS.	SCR Diode module is defective.	Check SCR/Diode module.
		IGBT module is defective.	Check IGBT module.
VSD Logic Board is defective.		Replace VSD Logic Board.	
SCR Trigger Board is defective.		Replace SCR Trigger Board.	
CHILLER FAULT: LOW AMBIENT TEMPERATURE	Ambient temperature is lower than the programmed operating limit.	Check the programmed cutout and determine if it is programmed correctly.	
	Ambient Sensor is defective.	Check the panel against the thermometer reading of ambient temperature.	
CHILLER FAULT: HIGH AMBIENT TEMPERATURE	Ambient Temperature is above the maximum operating limit.	Check outside air temperature.	
	Ambient Sensor is defective.	Check the Panel Display against Thermometer reading of Ambient Temperature at the sensor.	
CHILLER FAULT: LOW LEAVING CHILLED LIQUID	Leaving chilled liquid temperature drops faster than the unit can unload.	Check for restricted flow.	
		Check for rapid flow changes.	
		Water loop is too small.	
		Flow is below minimum for chiller.	
	Chilled Water Sensor is defective.	Check Sensor against Temp. Gauge in water line.	
		Check Sensor for intermittent operation. Check Wiring for shorts or opens.	
SYSTEM FAULT: CONTROL VOLTAGE	System Fuse is blown.	Check respective system Fuse 20FU or 21FU.	
SYSTEM FAULT: HIGH OIL TEMPERATURE	oil Temperature Sensor is defective.	Check Sensor with infrared to determine if reading is reasonable.	
	Condenser Fans NOT operating or running backwards.	Check Fans.	
	Coils dirty.	Check and clean Coils.	

NOTE: Always remove power to the chiller and assure the DC Bus voltage has bled off.

TABLE 18 - TROUBLESHOOTING GUIDE (CONT'D)

PROBLEM	POSSIBLE CAUSE	ACTION
SYSTEM FAULT: HIGH DISCHARGE PRESSURE	Coils dirty.	Check and clean coils.
	Coils are damaged.	Comb out fins.
	Fans NOT operating.	Check fan fuses.
		Check fan rotation.
		Check fan motor/blade.
System is overcharged.	Remove charge and check subcooling.	
SYSTEM FAULT: HIGH DISCHARGE TEMPERATURE	Discharge Temperature Sensor is defective.	Check Sensor.
	Condenser Fans NOT operating or are running backwards.	Check Fans.
	Coils dirty.	Check and clean Coils.
	High Superheat.	measure Superheat with gauges and thermocouple. Determine cause.
SYSTEM FAULT: HIGH MOTOR TEMPERATURE	High motor temperature input from one of the sensors.	Refrigerant charge low. Check subcooling.
		Excess charge in system, High discharge pressure. Check subcooling.
		High Superheat. Drain/Feed Valves NOT controlling. Isolate cause.
		motor Sensor reading incorrectly. Program panel to ignore a single sensor.
		Economizer Solenoid energized at low speeds. Valve is leaking through.
SYSTEM FAULT: LOW SUCTION PRESSURE	Low charge.	Check subcooling.
	Transducer reads incorrectly.	Check transducer against a gauge.
	Suction Temp. Sensor reads incorrectly.	Check sensor against a thermocouple.
	Low flow.	Check flow.
	Condenser Drain (Flash Tank Feed) Valve NOT operating.	Check Feed and Drain Valve operation. Check superheat.
	Condenser or Drain (Flash Tank Feed) Valve defective.	Check Feed and Drain Valve operation. Check superheat.
SYSTEM FAULT: DISCHARGE PRESSURE LIMITING	Discharge Transducer is defective.	Check transducer against a gauge.
	Ambient Temp. very high.	Normal operation.
	Fans NOT operating.	Check fan operation.
	Remote or local discharge pressure load limiting is programmed.	Normal operation.

NOTE: Always remove power to the chiller and assure the DC Bus voltage has bled off.

TABLE 18 - TROUBLESHOOTING GUIDE (CONT'D)

PROBLEM	POSSIBLE CAUSE	ACTION
SYSTEM STATUS: MOTOR CURRENT LIMITING	A high motor current anticipatory control has activated current limiting	Ambient temperature is high, normal response from controller
		Remote or panel limiting is in effect, Normal response.
		Excess charge in system, adjust charge.
		Condenser coils dirty, Clean condenser.
		Fans NOT operating. Check fans.
VSD FAULT: HIGH VASEPLATE TEMPERATURE	Coolant level low.	Add coolant.
	Glycol Pump is defective.	Replace Glycol Pump.
	VSD Board is defective	Replace VSD Logic Board.
	IGBT module is defective.	Check defective IGBT module.
VSD FAULT: LOW DC BUS VOLTAGE	SCR / Diode module is defective.	Check SCR / Diode module.
	SCR Trigger Board is defective.	Check SCR Trigger Board.

NOTE: Always remove power to the chiller and assure the DC Bus voltage has bled off.

CHILLED LIQUID AND SUCTION TEMPERATURE SENSOR INPUT VOLTAGETABLE 19- TEMPERATURE INPUT VOLTAGE SENSORTABLE
(MEASURED SIGNAL TO SHIELD AT THE SENSOR)

TEMP. °F (°C)	VOLTAGE	TEMP. °F (°C)	VOLTAGE	TEMP. °F (°C)	VOLTAGE
16.1 (-8.8)	1.52	35.9 (2.2)	2.19	55.6 (13.1)	2.85
16.7 (-8.5)	1.54	36.5 (2.5)	2.21	56.3 (13.5)	2.87
17.3 (-8.2)	1.56	37.0 (2.8)	2.23	56.9 (13.8)	2.89
17.9 (-7.8)	1.58	37.6 (3.1)	2.25	57.5 (14.2)	2.91
18.5 (-7.5)	1.60	38.2 (3.4)	2.27	58.1 (14.5)	2.93
19.1 (-7.2)	1.62	38.7 (3.7)	2.29	58.7 (14.8)	2.95
19.7 (-6.8)	1.64	39.3 (4.1)	2.30	59.4 (15.2)	2.97
20.3 (-6.5)	1.66	39.9 (4.4)	2.32	60.0 (15.6)	2.99
20.9 (-6.2)	1.68	40.4 (4.7)	2.34	60.6 (15.9)	3.01
21.5 (-5.8)	1.70	41.0 (5.0)	2.36	61.3 (16.3)	3.03
22.1 (-5.5)	1.72	41.6 (5.3)	2.38	61.9 (16.6)	3.05
22.7 (-5.2)	1.74	42.1 (5.6)	2.40	62.5 (16.9)	3.07
23.3 (-4.8)	1.76	42.7 (5.9)	2.42	63.2 (17.3)	3.09
23.9 (-4.5)	1.78	43.3 (6.3)	2.44	63.8 (17.7)	3.11
24.5 (-4.2)	1.80	43.9 (6.6)	2.46	64.5 (18.1)	3.13
25.0 (-3.9)	1.82	44.4 (6.9)	2.48	65.1 (18.4)	3.14
25.6 (-3.6)	1.84	45.0 (7.2)	2.50	65.8 (18.8)	3.16
26.2 (-3.2)	1.86	45.6 (7.5)	2.52	66.5 (19.2)	3.18
26.8 (-2.9)	1.88	46.2 (7.9)	2.54	67.1 (19.5)	3.20
27.3 (-2.6)	1.90	46.7 (8.2)	2.56	67.8 (19.9)	3.22
27.9 (-2.8)	1.91	47.3 (8.5)	2.58	68.5 (20.3)	3.24
28.5 (-1.9)	1.93	47.9 (8.8)	2.60	69.2 (20.7)	3.26
29.0 (-1.7)	1.95	48.5 (9.2)	2.62	69.9 (21.1)	3.28
29.6 (-1.3)	1.97	49.1 (9.5)	2.64	70.6 (21.4)	3.30
30.2 (-1)	1.99	49.7 (9.8)	2.66	71.3 (21.8)	3.32
30.8 (-0.7)	2.01	50.3 (10.2)	2.68	72.0 (22.2)	3.34
31.3 (-0.4)	2.03	50.8 (10.4)	2.70	72.7 (22.6)	3.36
31.9 (-0.1)	2.05	51.4 (10.8)	2.71	73.4 (23)	3.38
32.5 (0.3)	2.07	52.0 (11.1)	2.73	74.2 (23.4)	3.40
33.0 (0.6)	2.09	52.6 (11.4)	2.75	74.9 (23.8)	3.42
33.6 (0.9)	2.11	53.2 (11.8)	2.77		
34.2 (1.2)	2.13	53.8 (12.1)	2.79		
34.8 (1.5)	2.15	54.5 (12.5)	2.81		
35.3 (1.8)	2.17	55.0 (12.8)	2.83		

TABLE 20- OUTSIDE AIR TEMPERATURE SENSOR INPUT VOLTAGE
(MEASURED SIGNAL TO SHIELD AT THE ENSOR)

TEMP. °F (°C)	VOLTAGE	TEMP. °F (°C)	VOLTAGE	TEMP. °F (°C)	VOLTAGE
0.24 (-17.6)	0.68	49.8 (9.9)	2.00	93.3 (34.1)	3.31
1.79 (-16.8)	0.71	50.7 (10.4)	2.03	94.4 (34.7)	3.34
3.30 (-15.9)	0.74	51.6 (10.9)	2.06	95.6 (35.3)	3.37
4.76 (-15.1)	0.77	52.5 (11.4)	2.09	96.8 (36)	3.40
6.19 (-14.3)	0.80	53.4 (11.9)	2.11	98.0 (36.7)	3.43
7.58 (-13.6)	0.83	54.3 (12.4)	2.14	99.2 (37.3)	3.46
8.94 (-12.8)	0.85	55.3 (12.9)	2.17	100.4 (38)	3.49
10.3 (-12.1)	0.88	56.2 (13.4)	2.20	101.6 (38.7)	3.52
11.6 (-11.3)	0.91	57.1 (13.9)	2.23	102.9 (39.4)	3.55
12.8 (-10.7)	0.94	58.0 (14.4)	2.26	104.2 (40.1)	3.57
14.1 (-9.9)	0.97	58.9 (14.9)	2.29	105.5 (40.8)	3.60
15.3 (-9.3)	1.00	59.8 (15.4)	2.32	106.8 (41.6)	3.63
16.5 (-8.6)	1.03	60.7 (15.9)	2.35	108.1 (42.3)	3.66
17.7 (-7.9)	1.06	61.6 (16.4)	2.38	109.5 (43.1)	3.69
18.9 (-7.3)	1.09	62.6 (17)	2.41	110.9 (43.8)	3.72
20.0 (-6.7)	1.12	63.5 (17.5)	2.44	112.3 (44.6)	3.75
21.2 (-6)	1.15	64.4 (18)	2.47	113.8 (45.4)	3.78
22.3 (-5.4)	1.18	65.3 (18.5)	2.50	115.2 (46.2)	3.81
23.4 (-4.8)	1.21	66.3 (19.1)	2.52	116.7 (47.1)	3.84
24.4 (-4.2)	1.24	67.2 (19.5)	2.55	118.3 (47.9)	3.87
25.5 (-3.6)	1.26	68.1 (20.1)	2.58	119.9 (48.8)	3.90
26.6 (-3)	1.26	69.1 (20.6)	2.61	121.5 (49.7)	3.93
27.6 (-2.4)	1.32	70.0 (21.1)	2.64	123.2 (50.7)	3.96
28.7 (-1.8)	1.35	70.9 (21.6)	2.67	124.9 (51.6)	3.98
29.7 (-1.3)	1.38	71.9 (22.2)	2.70	126.6 (52.6)	4.01
30.7 (-0.7)	1.41	72.8 (22.7)	2.73	128.4 (53.6)	4.04
31.7 (-0.2)	1.44	73.8 (23.2)	2.76	130.3 (54.6)	4.07
32.7 (0.4)	1.47	74.8 (23.8)	2.76		
33.7 (0.9)	1.50	75.8 (24.3)	2.82		
34.7 (1.5)	1.53	76.7 (24.8)	2.85		
35.7 (2.1)	1.56	77.7 (25.4)	2.88		
36.7 (2.6)	1.59	78.7 (25.9)	2.91		
37.6 (3.1)	1.62	79.7 (26.5)	2.93		
38.6 (3.7)	1.65	80.7 (27.1)	2.96		
39.6 (4.2)	1.67	81.7 (27.6)	2.99		
40.5 (4.7)	1.70	82.7 (28.2)	3.02		
41.4 (5.2)	1.73	83.6 (28.7)	3.05		
42.4 (5.8)	1.76	84.6 (29.2)	3.08		
43.3 (6.3)	1.79	85.7 (29.8)	3.11		
44.3 (6.8)	1.82	86.7 (30.4)	3.13		
45.2 (7.3)	1.85	87.8 (31)	3.16		
46.1 (7.8)	1.88	88.9 (31.6)	3.19		
47.0 (8.3)	1.91	90.1 (32.3)	3.22		
48.0 (8.9)	1.94	91.1 (32.8)	3.25		
48.9 (9.4)	1.97	92.2 (33.4)	3.28		

TABLE 21- PRESSURE TRANSDUCER OUTPUT VOLTAGE
(MEASURED SIGNAL TO RETURN AT THE TRANSDUCER)

SUCTION PRESSURE TRANSDUCER (125 PSIG)		DISCHARGE CONDENSER LIQUID PRESSURE AND DISCHARGE PRESSURE TRANSDUCER (400 PSIG)	
PRESSURE	VOLTAGE	PRESSURE	VOLTAGE
0	0.50	0	0.50
5	0.66	25	0.75
10	0.82	50	1.00
15	0.98	75	1.25
20	1.14	100	1.50
25	1.30	125	1.75
30	1.46	150	2.00
35	1.62	175	2.25
40	1.78	200	2.50
45	1.94	225	2.75
50	2.10	250	3.00
55	2.26	275	3.25
60	2.42	300	3.50
65	2.58	325	3.75
70	2.74	350	4.00
75	2.90	375	4.25
80	3.06	400	4.50
85	3.22		
90	3.38		
95	3.54		
100	3.70		
105	3.86		
110	4.02		
115	4.18		
120	4.34		
125	4.50		

TABLE 22- MOTOR TEMPERATURE SENSOR RESISTANCE
(CHECK AT THE MOTOR)

TEMP. °F (°C)	R NOMINAL (OHMS)	R TOL (± %)	RMIN (OHMS)	RMAX (OHMS)
-4 (-20)	97,062	5.00	92,209	101,915
5 (-15)	77,941	4.60	69,586	76,296
14 (-10)	55,391	4.20	52,996	57,643
23 (-5)	42,324	3.85	40,695	43,954
32 (0)	32,654	3.50	31,511	33,797
41 (5)	25,396	3.15	24,596	26,196
50 (10)	19,903	2.80	19,346	20,461
59 (15)	15,713	2.50	15,321	16,106
68 (20)	12,493	2.20	12,218	12,768
77 (25)	10,000	2.00	9,800	10,200
86 (30)	8,056	2.40	7,863	8,250
95 (35)	6,531	2.70	6,354	6,707
104 (40)	5,326	3.00	5,166	5,485
113 (45)	4,368	3.25	4,226	4,510
122 (50)	3,602	3.50	3,476	3,728
131 (55)	2,986	3.75	2,874	3,098
140 (60)	2,488	4.00	2,389	2,588
149 (65)	2,083	4.25	1,995	2,172
158 (70)	1,753	4.50	1,674	1,832
167 (75)	1,481	4.75	1,411	1,551
176 (80)	1,257	5.00	1,194	1,321
185 (85)	1,071	5.20	1,016	1,127
194 (90)	916.9	5.40	867.4	966.4
203 (95)	787.7	5.60	743.6	831.9
212 (100)	679.3	5.80	639.9	718.7
221 (105)	587.9	6.00	552.6	623.2
230 (110)	510.6	6.20	479.9	542.3
239 (115)	445.0	6.40	416.5	473.5
248 (120)	389.0	6.60	363.4	414.7
257 (125)	341.2	6.70	318.4	364.1
266 (130)	300.2	6.90	279.5	320.9
275 (135)	264.9	7.10	246.1	283.7
284 (140)	234.4	7.30	217.3	251.5
293 (145)	208.0	7.40	192.6	223.3
302 (150)	185.0	7.50	171.1	198.9

WATER TREATMENT

TABLE 23 - COOLER WATER QUALITY REQUIREMENT

Item	Unit	Limit	Tendency	
			Corrosion	Scale
PH Value(25℃)	—	7.5~8.0	○	
SO ₄ ⁻⁻	ppm	<100	○	
HCO ₃ ⁻ / SO ₄ ⁻⁻	ppm	>1.0	○	
CL ⁻	ppm	<50	○	
PO ₄	ppm	<2.0	○	
NH ₃	ppm	<0.5	○	
Free Chlorine	ppm	<0.5	○	
Fe ⁺⁺⁺	ppm	<0.5	○	
Mn ⁺⁺	ppm	<0.05	○	
CO ₂	ppm	<10	○	
H ₂ S	ppb	<50	○	
Temperature	℃	<65	○	○
Oxygen Content	ppm	<0.1	○	
Total Hardness	dH	4.8-8.5	○	○

Note:

1. Water quality should be inspected before unit installation and regularly during unit operation. The parameters of water quality should meet the demand as above form. Once the parameter is over the limit, the heat exchanger will leak for corrosion and is possible to have serious scale formation.
2. When the parameter of water quality in projects that trend to corrosion is over the limit for a long time, the heat exchanger will leak for corrosion. The unit cannot operate normally and use as usual.
3. When the parameter of water quality in projects that trend to scale formation is over the limit for a long time, heat exchanger will have serious scale, which effects heat exchange and drops the cooling (heating) capacity directly.
4. Users should take on the lost that comes from the unqualified user's water quality.

SECTION 10 - DECOMMISSIONING, DISMANTLING AND DISPOSAL



Never release refrigerant to the atmosphere when emptying the refrigerating circuits. Suitable retrieval equipment must be used. If reclaimed refrigerant cannot be reused. It must be returned to the manufacturer.



Never discard used compressor oil, as it contains refrigerant in solution. Return used oil to the oil manufacturer.

Never discard used compressor oil, as it contains refrigerant in solution. Return used oil to the oil manufacturer.

Unless otherwise indicated, the operations described below can be performed by any properly trained maintenance technician.

GENERAL

Isolate all sources of electrical supply to the unit including any control system supplies switched by the unit. Ensure that all points of isolation are secured in the „OFF“ position. The supply cables may then be disconnected and removed. For connection points refer to *SECTION 4 - INSTALLATION*.

Remove all refrigerant from each system of the unit into a suitable container using a refrigerant reclaim or recovery unit. This refrigerant may then be re-used, if appropriate, or returned to the manufacturer for disposal. Under NO circumstances should refrigerant be vented to atmosphere. Drain the refrigerant oil from each system into a suitable container and dispose of according to local laws and regulations governing the disposal of oily wastes. Any spilt oil should be mopped up and similarly disposed of.

Isolate the unit heat exchanger from the external water systems and drain the heat exchanger section of the system. If no isolation valves are installed it may be necessary to drain the complete system.



If glycol or similar solutions have been used in the water system, or chemical additives are contained, the solution MUST be disposed of in a suitable and safe manner. Under NO circumstances should any system containing glycol or similar solutions be drained directly into domestic waste or natural water systems.

After draining, the water pipework can be disconnected and removed.

Packaged units can generally be removed in one piece after disconnection as above. Any fixing down bolts should be removed and then the unit should be lifted from position using the points provided and equipment of adequate lifting capacity.

Reference should be made to *SECTION 4 - INSTALLATION* on Page 23 for unit installation instructions, *SECTION 9 - MAINTENANCE* on Page 107 for unit weights and *SECTION 3 - HANDLING AND STORAGE* on Page 19 for handling.

Units which cannot be removed in one piece after disconnection as above must be dismantled in position. Special care should be taken regarding the weight and handling of each component. Where possible units should be dismantled in the reverse order of installation.



Residual refrigerant oil and glycol or similar solutions may remain in some parts of the system. These should be mopped up and disposed of as described above.

It is important to ensure that whilst components are being removed then the remaining parts are supported in a safe manner.



Only use lifting equipment of adequate capacity.

After removal from position the unit parts may be disposed of according to local laws and regulations.

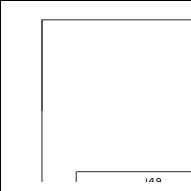

YORK Guangzhou Air Conditioning & Refrigeration Co., Ltd.

Phone: +86 763 4681111

Fax: +86 763 4681114



© 2011 Johnson Controls, Inc.

www.johnsoncontrols.com

FORM NO.: 201.28-NM1.1.EN.GB(1114)
SUPERSEDES: 201.28-NM1.1.EN.GB(0714)



- * Johnson Controls reserve all rights to product design changes without notification.
- ** Product performance detailed is agreed in the contract, this manual is for reference only.

SAP NO.: 745655